



**Make brands Happy  
when they expect more.**

**Sustainable European Manufacturer  
Pens & Notebooks.**





























# Catalogue Content

## About Happy brands





|                        |           |
|------------------------|-----------|
| <u>We are producer</u> | <u>5</u>  |
| <u>Sustainability</u>  | <u>7</u>  |
| <u>Services</u>        | <u>9</u>  |
| <u>Certificates</u>    | <u>11</u> |
| <u>Materials</u>       | <u>13</u> |
| <u>Sales support</u>   | <u>15</u> |

|                                     |   |
|-------------------------------------|---|
| <u>Gift Sets and wellcome packs</u> | <u>17</u>   |
| <u>CreaNote - bespoke Nonebook</u>  | <u>21</u>   |
| <u>Pantone Service</u>              | <u>23</u>   |
| <u>Mix&amp;Match</u>                |  <u>24</u> |
| <u>NFC services</u>                 | <u>26</u>   |





## Lecce Pen

|  |   |                           |   |
|--|---|---------------------------|---|
|   |   | ZEN R-ABS Clip Special    | <u>29</u>   |
|  |  | OTTO Clip Special         | <u>31</u>   |
|  |  | ZEN Swing Recycled        | <u>33</u>   |
|  |  | DGT 360° Printing         | <u>35</u>   |
|  |  | ZEN NFC                   | <u>36</u>   |
|  |  | ZEN QR                    | <u>37</u>   |
|  |  | TWIN Recycled <b>NEW!</b> | <u>39</u>   |
|  |  | ZEN Recycled              |  <u>43</u> |
|  |  | ZEN Bio                   |  <u>47</u> |
|  |  | FORTE Recycled            |  <u>49</u> |
|  |  | FORTE Bio                 | <u>51</u>   |
|  |  | FORTE Recycled SafeTouch  | <u>53</u>   |
|  |  | RE-PEN Push New           |  <u>55</u> |
|  |  | TANTRA                    | <u>57</u>   |
|  |  | OTTO White                | <u>59</u>   |
|  |  | TWISTY                    | <u>61</u>   |

## Ready for Assembling

|   |  |                               |           |
|---|--|-------------------------------|-----------|
|   |   | TRIS Chrome                   | <u>62</u> |
|   |  | TRIS Solid                    | <u>63</u> |
|   |  | GOLFF SafeTouch               | <u>64</u> |
|  |  | GOLFF Solid                   | <u>65</u> |
|  |  | KIKI Eco SafeTouch            | <u>66</u> |
|  |  | KIKI EcoLine EB               | <u>67</u> |
|   |  | KIKI EcoLine EW               | <u>68</u> |
|   |  | KIKI Solid                    | <u>69</u> |
|   |  | PowerBank Forte / Forte ST 71 |           |

## Special production Sk.

|  |  |             |           |
|--|--|-------------|-----------|
|  |  | GOLFF Green | <u>72</u> |
|  |  | ZEN Soft    | <u>73</u> |
|  |  | NOVE        | <u>74</u> |
|  |  | NOVE Swing  | <u>75</u> |

## Icon keys

- NEW! Novelty
- ★ Bestseller
- ↓ While stocks last
- Recycled PET
- Biodegradable
- Recycled R-ABS
- Recycled cartons

## Ask for

Products that we have in parts and will assemble for you.

## Special production 5k

Product excluded from regular offer, but we can produce it. Minimum 5000 pcs.









## While stocks last

Products that are only available while stocks last. They will no longer be produced in the future.







## B1<sup>®</sup> Be original

|  |   |     |   |
|--|---|-----|---|
|  | HEXAGONAL <span style="color: red;">NEW!</span> | 79  |   |
|  | MILLION Rose Gold                               | 81  | ★ |
|  | MILLION Gold                                    | 81  |   |
|  | MILLION Chrome                                  | 81  |   |
|  | MILLION Roller Chrome                           | 81  |   |
|  | IQ 32 GB  | 83  |   |
|  | MIRROR  | 85  |   |
|  | MIRROR  | 85  | ★ |
|  | CLICKER Touch Soft                              | 87  | ★ |
|  | TOUCHWRITER Soft                                | 89  |   |
|  | PRESS   | 91  | ★ |
|  | PRESS Roller                                    | 93  |   |
|  | PRESS Bi-color                                  | 95  | ★ |
|  | ELLE Metal Touch                                | 97  |   |
|  | ELLE Metal Touch Graphic                        | 99  |   |
|  | CLICKER Touch                                   | 101 |   |
|  | FORCE   | 103 |   |
|  | TATTOO  | 105 |   |
|  | IMPRESS   | 107 |   |
|  | TOUCHWRITER                                     | 109 |   |
|  | TANTRA Soft Metal                               | 110 |   |
|  | TANTRA Soft Touch                               | 111 |   |
|  | CASE  | 112 |   |

## Flaxyble cover

|  |             |      |       |
|--|-------------|------|-------|
|  | LADY GRS    | NEW! | 117   |
|  | SHADY GRS   |      | 119   |
|  | GRACY GRS   |      | 121 ★ |
|  | FUNKY GRS   |      | 123   |
|  | BIGGY GRS   |      | 125 ★ |
|  | CUBI GRS XL | NEW! | 127   |
|  | CUBI GRS    |      | 129   |
|  | AUDREY GRS  |      | 131   |

## Semi and hard cover

|  |                     |              |       |
|--|---------------------|--------------|-------|
|    | FRANKY GRS          | announcement | 133   |
|    | TRENDI GRS / TRENDI |              | 135   |
|    | TWIZZY              | ↓            | 137   |
|   | COMBI               | ↓            | 139   |
|  | BLACKY              | ↓            | 141   |
|  | JUSTY GRS           |              | 143 ★ |
|  | SILKY GRS           |              | 145 ★ |

## PowerBank

|  |                        |  |       |
|--|------------------------|--|-------|
|  | SIMPLY                 |  | 153 ★ |
|  | MELLOW                 |  | 155   |
|  | VELVET                 |  | 157   |
|  | SPARK                  |  | 161   |
|  | BEAM                   |  | 163   |
|  | GRAND                  |  | 165   |
|  | LEIF                   |  | 167   |
|  | LINK                   |  | 169 ★ |
|  | <b>Notebooks index</b> |  | 170   |

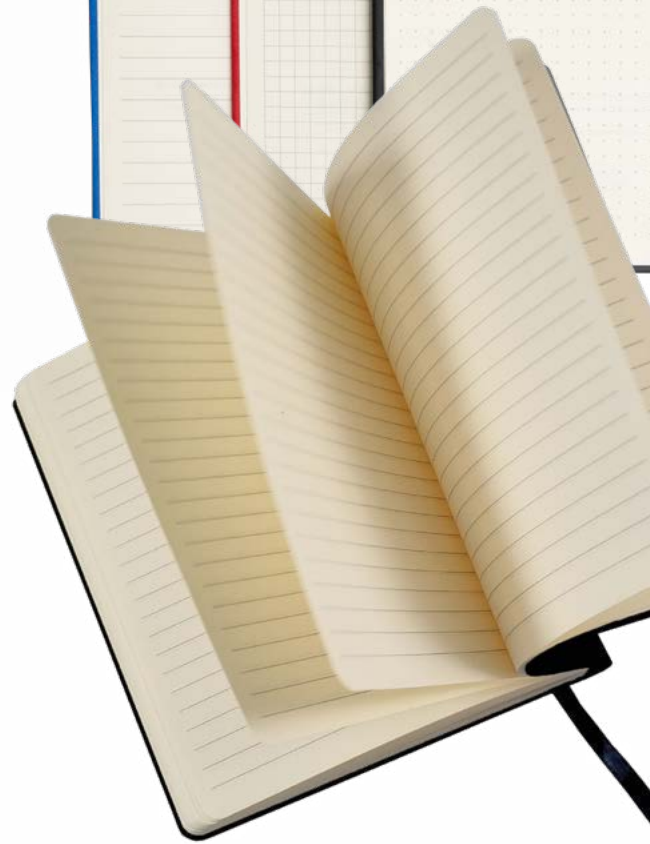

How can we help?

# Happy Brands

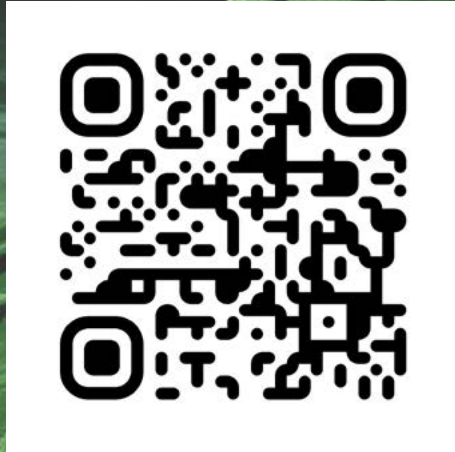

Check out  
the video!



We are a **European manufacturer** dedicated to helping brands and people worldwide communicate sustainably through **high-quality promotional products**.

We are **pioneers** in the promotion market, being **the first to prioritize** environmental sustainability. In **1992**, we created our **first pen from ecological materials**.

With over **30 years of experience** in designing and crafting authentic **eco-friendly products**, we have come a long way to offer you the finest promotional items available today.



# Why should we work together?

Caring for nature today is the foundation of our children's future



## Our products

- Made from **recycled** or **biodegradable** materials.
- Design focuses on **minimizing** weight and waste.
- We strive to use only **recycled** materials for packaging.
- We are committed to using **eco-friendly technologies** to produce our products.
- We produce **only sustainable** product from 2025!

## Our brands

- We strive to **minimize resource consumption**.
- We work with **environmentally friendly** transport companies.
- We use **only green energy**.

*our mission!*





We can bring any of your branding ideas to life!

# Services



How we do it!



## Promotional pens



pad printing



silkscreen printing 300 °



special clip



digital printing 360 °



digital printing

## Metal pens



pad printing



silkscreen printing 300 °



laser engraving mirror 300 °



laser engraving 300 °



bi-color laser engraving 300 °

## Notebooks



silkscreen printing



digital printing



inserts



Finochrom ®



embossing



embossing + metallic foil

# Certificates



We provide assurance,  
credibility, and transparency



*Ethical code  
of conduct*



We strive to achieving **100% sustainability** in our business. Connecting promotional products and brands to advance environmental and social responsibility, all while caring for people and the planet.

### **100 % ECO-friendly**

In 2025 we will stop using ABS material. All pens produced by us will be made of biodegradable or recycled materials. **ISCC Plus** – an international certification system for all sustainable raw materials. Certifies not only primary bio-based raw materials, but also recycles, i.e. recycled plastics. In this way, it confirms that the raw materials used to produce new plastics come from sustainable sources and comply with the principles of a circular economy.

*See all our  
certificates*



We are striving to be **100% eco-friendly and human-friendly**. Our notebooks will become a part of your identity and comfortable personal space, providing a smooth and soft tactile experience, designed to look and feel like they should. It is worth noting that our thinking about the sustainable use of natural resources translates into concrete action.

**FSC® the paper used to create THINKme notebooks is certified by the international**, restrictive environmental organization **FSC® (Forest Stewardship Council A.C.)**, which promotes responsible management of forest resources in the world and is represented by Representatives in over 50 countries.



The mark of  
responsible forestry

# Materials

A stylized landscape painting with rolling hills in various shades of green, yellow, and brown, under a bright yellow sky with a white sun.

By choosing sustainable materials, Brands and businesses contribute to a healthier planet by reducing waste, pollution, and resource consumption

## Biodegradable

The employed materials are the real answer to the customer demand for product with low environmental impact, even the pen colors are obtained through the use of biodegradable masterbatches. Made by nature, for nature. Bioplastic is made from materials that come from biological sources such as sugar cane, potato starch or wood cellulose, straw or corn. The Bio-Plastic employed in the production of the biodegradable pens come from renewable sources and go back to the earth through processes of the biodegradation and composing without the release of pollutants. It contains renewable raw materials such as non-genetically modified corn starch. Our pens made from corn starch (except springs and refills) are produced according to the European Union regulations: biodegradation of at least 90% of the material in less than 6 months.



 R-PET

The line of writing articles made with recycled PET coming from the collection of industrial waste and post-consumer products like water and soft drink bottles, food packaging, boxes. Once the differentiated collection is carried out and the material is transported to special sorting centres, this is shredded and regenerated in the form of flakes and granules. Thanks to its characteristics, PET can then be reused to create new products. The recycled PET thus becomes R-PET.



**GRS** 

The GRS Thinkme PU Notebook is a stylish and eco-friendly choice for those who care about sustainability. Its cover is crafted from recycled materials, specifically post-consumer polyester derived from waste plastic bottles, ensuring a positive environmental impact. For every notebook produced, the equivalent of one 0.5L plastic bottle is recycled, giving new life to waste materials.

By choosing the GRS Thinkme Notebook, you not only get a functional and elegant product but also actively contribute to reducing plastic waste. It's an ideal choice for environmentally conscious individuals or businesses seeking branded sustainable stationery solutions.

**Happy Brands** 

## Recycled

Ecoline is a line of pens produced out of recycled drink (beverage) cartons and for that reason the surface of those pens is not completely smooth. For printing on our pens we use ecological, low toxic paints compliant with EU REACH norm. Our first priority is to use recycled materials in order to protect the natural environment. Thanks to us today's waste will become a useful product – an alternative solution for schools, offices and a households. By offering this ecological product to your client you create the image of yourself as an expert in ecology which helps to establish a positive association of your brand. Due to the specific properties and fragments of recycled materials, ecological pens differ in shade and color from the standard Lecce Pen colors.



**R<sup>3</sup>ABS**

The RE-ABS pen is made from recycled plastic, thus helping to give a second life to products that would otherwise have to be disposed of with which involves additional energy consumption. The use of recycled plastics is part of a broader concept of circular economy, which represents an alternative model characterized by greater sustainability than the traditional linear economy.

- In a circular economy, resources are used as long as possible, making the most of their value during the entire life. At the end of their use they are recovered and regenerated to give them a second life.
- The linear model follows the path of production, use and disposal.

**SafeTouch™**   
antibacterial

SafeTouch Antibacterial™ an ideal solution for public places where the pen is passed on from hand to hand, and where children play. An antibacterial component added to the plastic is active through out the entire life cycle of the pen. After 24h 90% of bacteria are killed. The antibacterial effect has been confirmed and certified. The material is completely safe for the skin

# Sales Support



- Enhances Customer Experience
- Builds Trust and Credibility
- Improves Decision-Making
- Personalizes the Sales Pitch
- Supports Product Education
- Facilitates Long-Term Relationships
- Drives Differentiation
- Saves Time in Negotiations

**Our Sample kits** designed to bridge the gap between concept and reality, empowering **clients to see and feel the value of product**. They're a **powerful tool** to enhance trust, speed up decisions, and ultimately close more deals!



*Please ask  
for sales tools*



# Gift Sets and welcome packs



- Creates a Positive First Impression
- Improves Productivity
- Eases the onboarding Process
- Rise employer Brand loyalty
- Boosts Engagement and Motivation
- Promotes a Sense of Belonging
- Supports Cultural Alignment

Product code: TM20215/01 | TM20215/35

# POWERBOX

Well-designed welcome pack is a small investment with significant returns in employee satisfaction, loyalty, and productivity.

check it out!

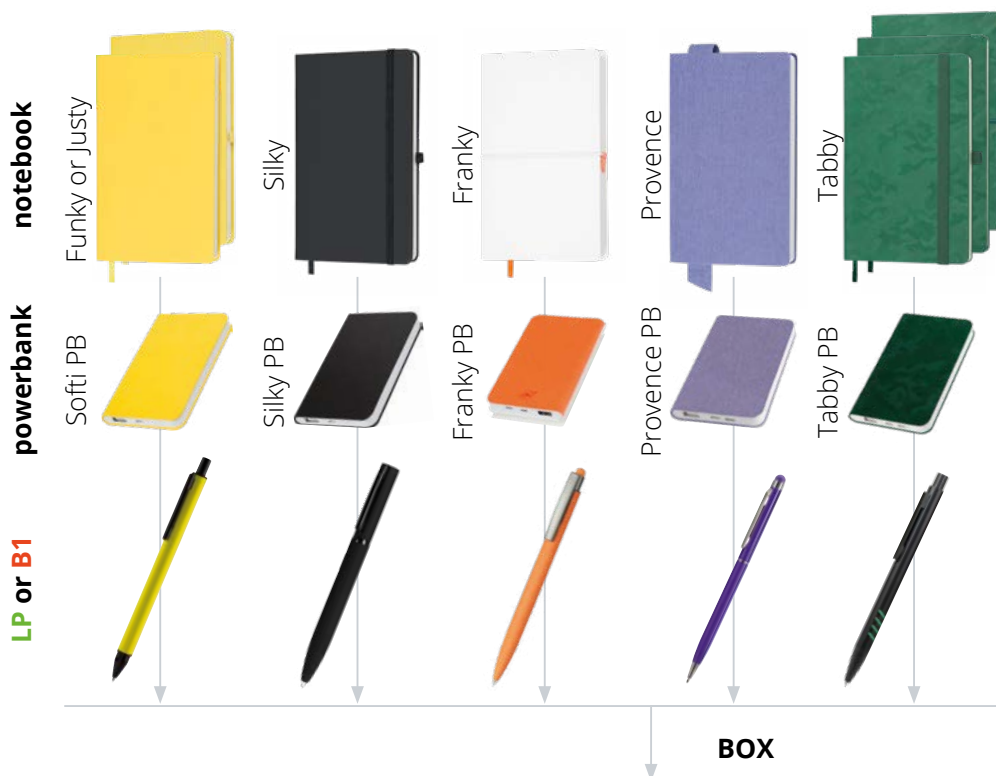

EN

Notebook, powerbank and pen in a box. Products and wrappers for individual labelling.

PL

Notes, powerbank i długopis w pudełku. Produkty i opakowania do indywidualnego oznakowania.

IT

Notebook, powerbank e penna in una scatola. Prodotti e imballaggi per etichettatura individuale.

FR

Carnet, powerbank et stylo dans une boîte. Produits et emballages pour étiquetage individuel.

DE

Notizbuch, Powerbank und Stift in einer Box. Produkte und Verpackungen für individuelle Kennzeichnung.

ES

Cuaderno, powerbank y bolígrafo en una caja. Productos y envoltorios para etiquetado individual.

table of contents

# DUO BOX

check it out!



EN

Notebook and pen in a box. Products and wrappers for individual labelling.

PL

Notes i długopis w pudełku. Produkty i opakowania do indywidualnego oznakowania.

IT

Notebook e penna in una scatola. Prodotti e imballaggi per etichettatura individuale.

FR

Carnet et stylo dans une boîte. Produits et emballages pour étiquetage individuel.

DE

Notizbuch und Stift in einer Box. Produkte und Verpackungen für individuelle Kennzeichnung.

ES

Cuaderno y bolígrafo en una caja. Productos y envoltorios para etiquetado individual.

Product code: PBF..

# FORTE BOX

check it out!



+



-



## Solid



## Soft



## SafeTouch



## Box



EN

Full colour matching possible. Powerbank and Forte pen. PB with possibility of thermal transfer. **Create a set tailored to your brand!**

PL

Możliwość dopasowania pełnej kolorystyki. Powerbank i długopis Forte. Powerbank z możliwością nadruku termotransferowego. **Stwórz zestaw dopasowany do swojej marki!**

IT

Possibilità di abbinamento completo dei colori. Powerbank e penna Forte. Powerbank con possibilità di trasferimento termico. **Crea un set personalizzato per il tuo marchio!**

FR

Possibilité de correspondance des couleurs complète. Powerbank et stylo Forte. Powerbank avec possibilité de transfert thermique. **Créez un ensemble adapté à votre marque!**

DE

Vollständige Farbzuordnung möglich. Powerbank und Forte-Stift. Powerbank mit der Möglichkeit des Thermotransfers. **Erstellen Sie ein Set, das auf Ihre Marke zugeschnitten ist!**

ES

Posibilidad de combinación de colores completa. Powerbank y bolígrafo Forte. Powerbank con posibilidad de transferencia térmica. **¡Crea un set a medida para tu marca!**

# CreaNote

Notebooks and calendars fully personalized to the needs  
of your brand



Personalized notebooks are a great way to keep your brand always at hand! You can choose every detail – from the cover color and page layout to a slogan or logo that will remind everyone of your company. Perfect as a practical office accessory or a gift for clients. Tailor-made notebooks that combine functionality with a unique style – your style!

# Easy-peasy Creation!

1 Choose shape & cover material of notebook



semi-hardcover



hardcover

2 Choose notebook accessory

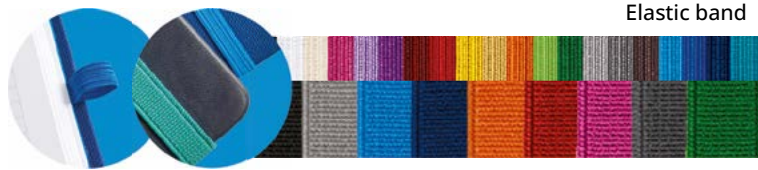

Elastic band



Ribbon



3 Choose pattern and type of block

### Daily

Format: A5 / B5 / A4



### Weekly

Format: A6 / B5 / A4



### English

Format: B5



### Types blocks

130 × 208 mm

White: Lined, Squared, Blank, Recycled - lined  
Chamois: Lined, Dotted

169 × 240 mm

White: Lined

The corners of the blocks are rounded.



### Paper Notebooks

With CMYK color printing and a non-scratch foil.

Fill out the form and send your request



There may occur colour differences between different lots of materials

table of contents

# Cover Materials

The available cover options include a wide range of materials and colors, including PU covers, various paper-based materials with additives, and covers made from recycled plastic waste or recycled leather. Each of these materials is designed with the goal of perfectly aligning with the brand's image, combining aesthetics with functionality while catering to the diverse needs of users.

## OCEAN

Canvas woven from recycled plastic collected from oceans. Yarn used for its production consists of 100% of recycled plastic. Canvas-like surface in irregular colour, very durable. Available in green, coral, light blue.

## ECONATURAL

Bonded leather made from 100% recycled leather scraps and natural latex. Very durable and soft to the touch.

## ECO PAPERS

A range of recycled papers obtained from the food and textile industries or from paper waste.

### Corn

Ecological paper containing corn waste from food production

### Citrus

Ecological paper containing citrus fruit waste from food production

### Coffee

paper derived from 100% post-consumer recycled waste, 5% paper derived from are left-overs from coffee production

### Cotton

paper produced with textile industry waste

### Wool black / Wool blue

recycled paper partially made of post-production waste from textile industry

### Grass

100% recycled paper, minimum 30% grass fibers

### Cora

dyed-through paper with cork resembling surface

### Kraft

paper produced from 30%, recycled fibers

### Juta

paper-based material with a canvas-like surface

### Wood

paper-based material imitating tree bark

# Pantone Service

Create a Pen in Your Brand's Colors

Starting from just 5,000 pieces, we can create a pen in colors based on the Pantone scale. A pen in a single color or each element in a different shade? The choice is yours!



Contact us for  
production!





# FANTASY

## Mix&Match

#creativity

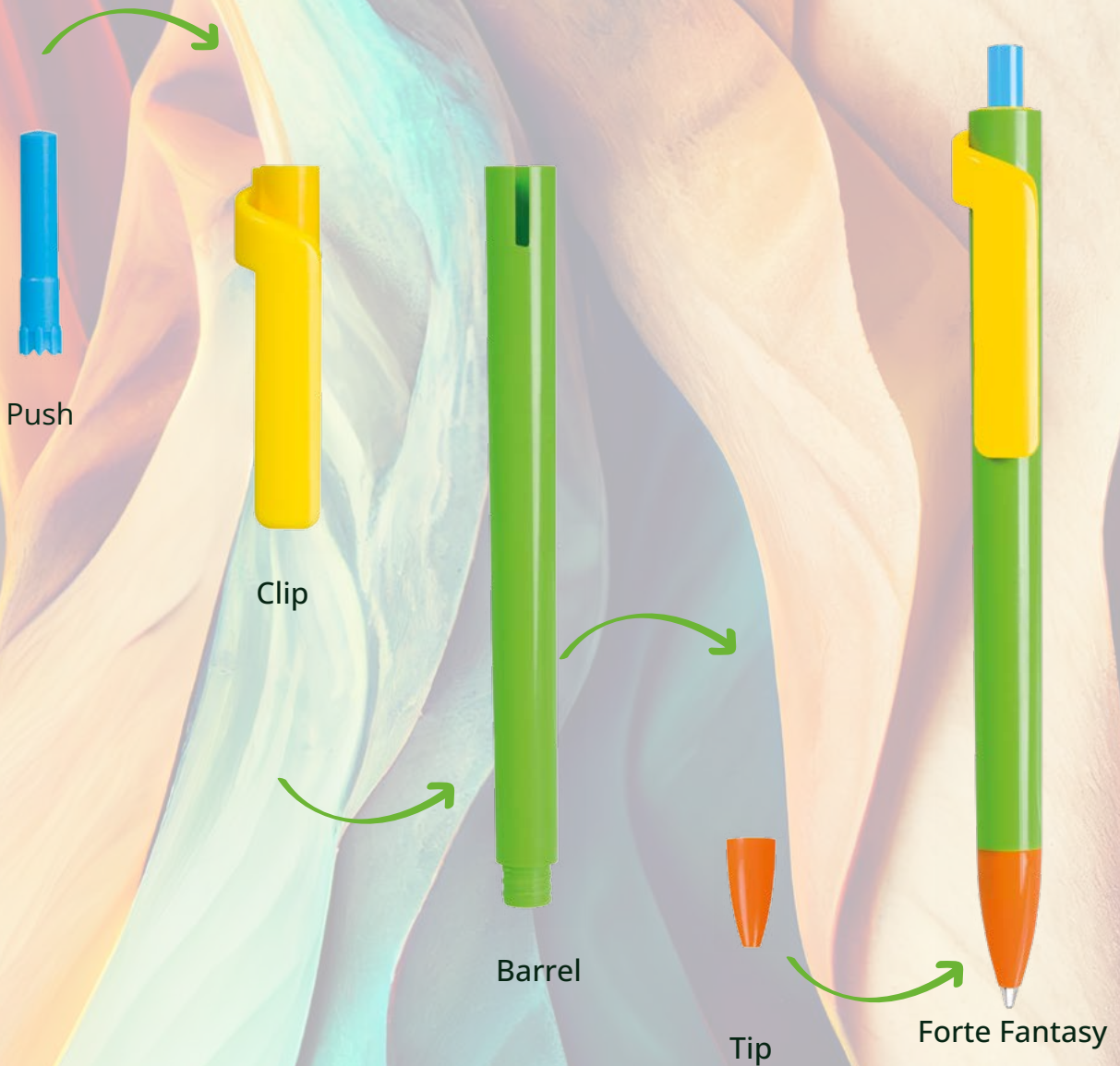

Lecce Pen

Ask For

# FANTASY Mix&Match

EU Production

check it out!

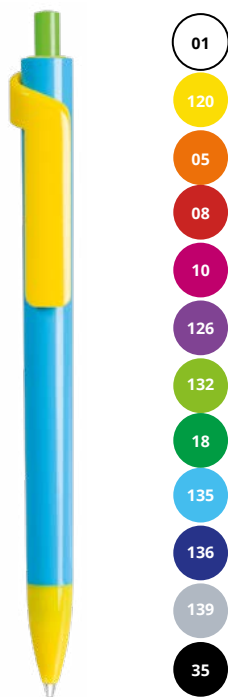

FORTE

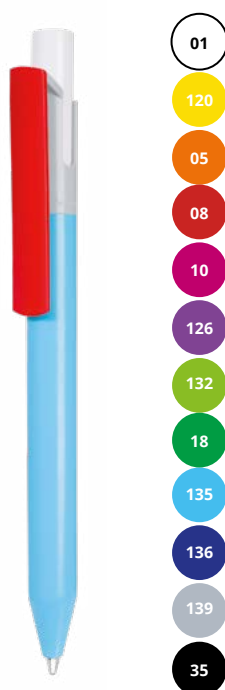

ZEN



GOLFF



KIKI



TWIN



TRIS

EN

You can meet the expectations and individual needs of most demanding customers by mixing the colors of components. You can choose from the colors available for a specific model.

Mix freely!

PL

Możesz spełnić oczekiwania i indywidualne potrzeby najbardziej wymagających klientów poprzez mieszanie kolorów komponentów. Można wybi rać spośród kolorów dostępnych dla konkretnego modelu.

Mieszaj dowolnie!

IT

È possibile soddisfare le aspettative e le esigenze individuali dei clienti più esigenti mescolando i colori dei componenti. Potete scegliere tra i colori disponibili per un modello specifico.

Mescolate liberamente!

FR

Vous pouvez répondre aux attentes et aux besoins individuels des clients les plus exigeants en mélangeant les couleurs des composants. Vous pouvez choisir parmi les couleurs disponibles pour un modèle spécifique.

Mélangez librement !

DE

Sie können die Erwartungen und individuellen Bedürfnisse der anspruchsvollsten Kunden erfüllen, indem Sie die Farben der Komponenten mischen. Sie können aus den für ein bestimmtes Modell verfügbaren Farben wählen.

Frei mischen!

ES

Puede satisfacer las expectativas y necesidades individuales de los clientes más exigentes mezclando los colores de los componentes. Puede elegir entre los colores disponibles para un modelo concreto.

¡Mezcle libremente!

table of contents

# ZEN • NFC )))

## Service

A pen that can do more! Designed to take full advantage of NFC - contactless and wireless communication technology. It is enough to scan the pen clip in a few seconds and get access to publications, videos, pages, documents and many more saved under the link.



Turn on NFC  
on your phone



Put your phone  
close to the NFC tag



Enjoy the ink!



check  
it out!



01

120

05

08

10

126

132

18

135

136

139

35





*Lecce Pen*

*First European sustainable promotional pen producer.  
Traditions and production expertise since 1953.*



Lecce Pen

# ZEN R-ABS Clip Special

*#eco #creativity*



*See how  
we make!*



*check it out!*

table of contents

Product code: 191R\_Clip..

# ZEN R-ABS Clip Special

EU Production

## Colors



**01**  
PMS White

**EN**

Pen made of **R-ABS, recycled plastic** from small household appliances and electronics. **Individual shape clip.**

**PL**

Długopis z **R-ABS, recyklingu plastiku** pochodzącego z małego AGD i elektroniki. **Klips w indywidualnym kształcie.**

**IT**

Penna in plastica riciclata da piccoli elettrodomestici ed elettronica. **Clip in forma speciale.**

**FR**

Stylo en **R-ABS, plastique recyclé** issu du des petits appareils électoménagers. **Clip à la forme.**

**DE**

Stift aus **R-ABS, recyceltem Kunststoff** aus Haushaltskleingeräten und Elektronik. **Individuell geformter Clip.**

**ES**

Bolígrafo fabricado con **R-ABS, plástico reciclado** de pequeños electrodomésticos y aparatos electrónicos. **Clip de forma individual.**

## Specification

|                   |             |                 |              |                 |       |                  |                                  |                         |           |
|-------------------|-------------|-----------------|--------------|-----------------|-------|------------------|----------------------------------|-------------------------|-----------|
| <b>Dimensions</b> | 11 x 143 mm | <b>Material</b> | Recycled ABS | <b>Finishes</b> | Solid | <b>Ink color</b> | Blue, Black ( <i>on demand</i> ) | <b>Packaging (pcs.)</b> | 50 / 1000 |
|-------------------|-------------|-----------------|--------------|-----------------|-------|------------------|----------------------------------|-------------------------|-----------|

## Branding options

### Clip

Digital overprint

Pad printing

*individual (depending on the clip size)*

*individual (depending on the clip size)*

### Barrel

Digital overprint Side B and D

Silkscreen printing 300° (*Standard*) Side A

Silkscreen printing 300° XL (*On demand*) Side A

5 x 75 mm

30 x 45 mm

30 x 60 mm

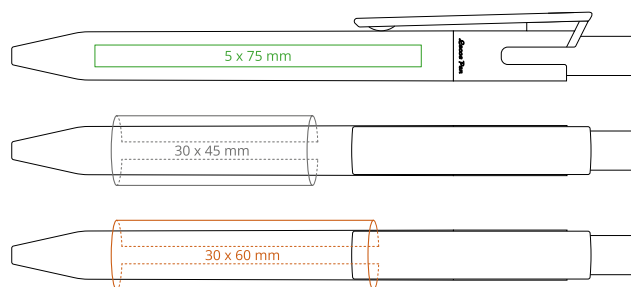

## Palette colors - BARREL



|     |     |     |
|-----|-----|-----|
| 01  | 10  | 135 |
| 120 | 126 | 136 |
| 05  | 132 | 139 |
| 08  | 18  | 35  |

table of contents

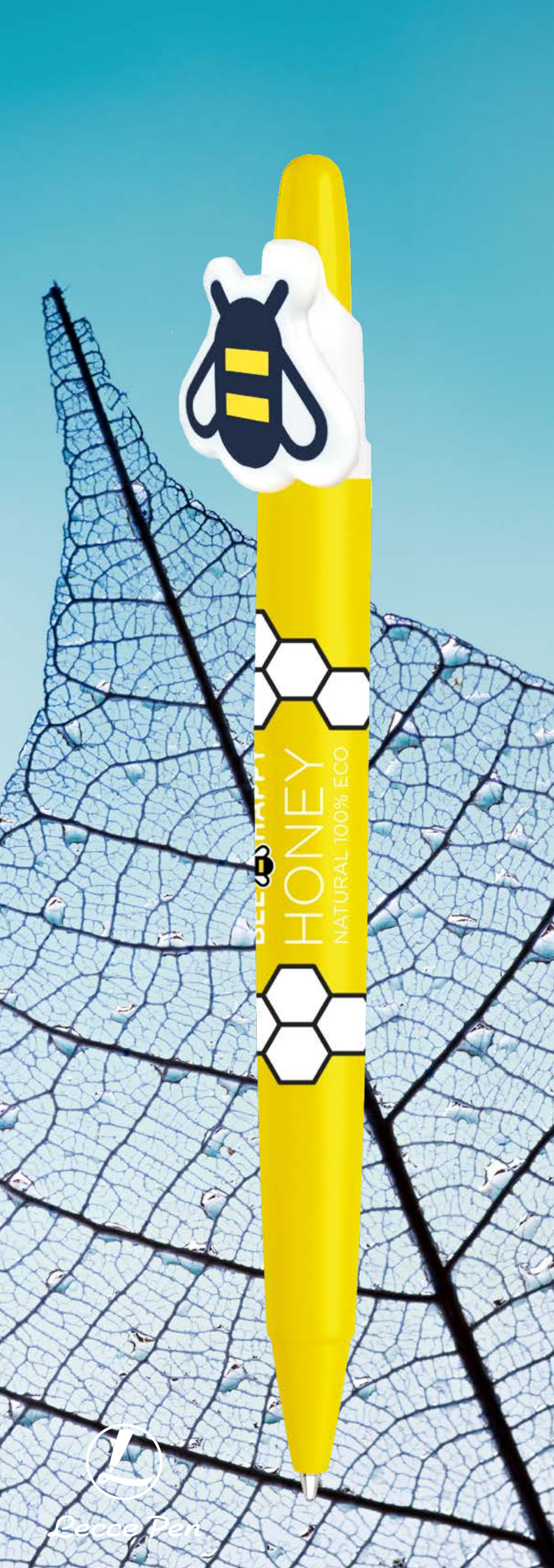

Recce Pen

# OTTO Clip Special

*#creativity*

check it out!



## Aak For

table of contents

Product code: FOT..

# OTTO Clip Special

EU Production

## Colors



**05** PMS 1585    **08** PMS 7620    **11** PMS 2607    **22** PMS 298    **25** PMS 662    **35** PMS Black

### EN

Otto Fantasy. **Create** a pen in the perfect colors for your brand. Plastic ballpen with special or standard white clip, assembly in standard range of Otto colors.

Choose between a **Standard Clip** in one of the available shapes or a **Special Clip** in an individual shape based on your project.

### PL

Otto Fantazja FOT **stwórz** swój długopis w kolorach dopasowanych do swojej marki. Długopis plastikowy, z klipsem logo, montaż w ramach standardowej kolorystyki modelu. Klipsy białe.

Wybierz pomiędzy **Klipsem Standard** w jednym z dostępnych wzorów lub **Klipsem Special** w indywidualnym kształcie na podstawie Twojego projektu.

### IT

Fantasia Otto. **Create** una penna nei colori perfetti per il vostro marchio. penna a sfera in plastica con clip bianca speciale o standard, assemblata nella gamma standard di colori Otto.

Scegliete tra una **clip standard** in una delle forme disponibili o una **clip speciale** in una forma personalizzata in base al vostro progetto.

### FR

Otto Fantasy. Créez un stylo aux couleurs parfaites pour votre marque. Stylo-bille en plastique avec clip blanc spécial ou standard, assemblage dans la gamme standard des couleurs Otto.

Choisissez entre un **clip standard** dans l'une des formes disponibles ou un **clip spécial** dans une forme individuelle en fonction de votre projet.

### DE

Otto Fantasia FOT **kreiert** Ihren Stift in den Farben Ihrer Marke. Kunststoffkugelschreiber mit Logo-Clip, passend zur Standardfarbgebung des Modells. Weißer Clip.

Wählen Sie je nach Ihrem Projekt zwischen einem **Standard-Clip** in einer der verfügbaren Formen oder einem **Sonder-Clip** in einer individuellen Form.

### ES

Fantasia Otto. Cree un bolígrafo en los colores efectivos para su marca. Bolígrafo lástic con clip blanco especial o estándar, montaje en la gama estándar de colores Otto.

Elija entre un **clip estándar** con una de las formas disponibles o un **clip especial** con una forma individual basada en su proyecto.

## Specification

|                   |             |                 |     |                 |              |                  |                         |                         |           |
|-------------------|-------------|-----------------|-----|-----------------|--------------|------------------|-------------------------|-------------------------|-----------|
| <b>Dimensions</b> | 13 x 148 mm | <b>Material</b> | ABS | <b>Finishes</b> | Solid, Frost | <b>Ink color</b> | Blue, Black (on demand) | <b>Packaging (pcs.)</b> | 50 / 1000 |
|-------------------|-------------|-----------------|-----|-----------------|--------------|------------------|-------------------------|-------------------------|-----------|

## Branding options

### Clip

Digital overprint

Pad printing

individual (depending on the clip size)

individual (depending on the clip size)

### Barrel

Digital overprint Side B,D

Silkscreen printing 300° (Standard) Side A

Silkscreen printing 300° XL (On demand) Side A

5 x 60 mm

32 x 45 mm

32 x 60 mm

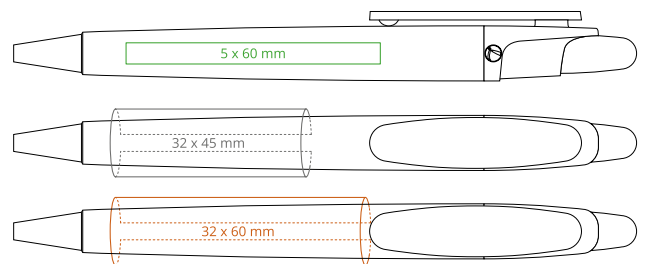

Standard special clip







Lecce Pen

# ZEN SWING Recycled

#eco

Check out the  
video on YT and  
see how zen  
swing works!

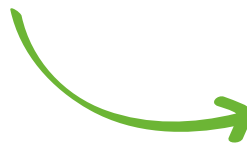

check it out!



table of contents

Product code: 191R-Swing

# ZEN Swing Recycled

EU Production

## Colors



**90**  
PMS Neutral

Graphic or 6 messages  
inside inner tube

Possibility to mix&match with standard colours – Barrel always transparent!

EN

**Rotating tube** inside allows you to show several brands that are in your company's portfolio, one product - **multiple messages**, many different promotional messages on one **eco-friendly pen**. Create a pen perfectly matched to your brand. Ballpen made of recycled material **with internal rotating tube**. Transparent barrel and accessories.

PL

**Rotująca tuba** wewnątrz pozwala na zaprezentowanie kilku brandów będących w portfolio firmy, jeden produkt - **wielokrotny przekaz**, wiele różnych komunikatów promocyjnych na jednym **ekologicznym długopisie**. Stwórz długopis w dopasowanych do swojej marki. Długopis z materiału z recyklingu z **wewnętrzną tubką rotującą**. Korpus i dodatki transparentne.

IT

**Il tubo rotante** all'interno consente di mostrare diversi marchi presenti nel portafoglio della vostra azienda, un solo prodotto - **più messaggi**, molti messaggi promozionali diversi su un'unica penna ecologica. Create una penna perfettamente abbinata al vostro marchio. **Penna a sfera in materiale riciclato con tubo rotante interno**. Fusto e accessori trasparenti.

FR

**Le tube rotatif** à l'intérieur vous permet de présenter plusieurs marques qui font partie du portefeuille de votre entreprise, un produit - **plusieurs messages**, plusieurs messages promotionnels différents sur un seul stylo écologique. Créez un stylo parfaitement adapté à votre marque. **Stylo-bille en matériau recyclé avec tube rotatif interne**. Corps et accessoires transparents.

DE

**Die drehbare Hülse** im Inneren ermöglicht es Ihnen, mehrere Marken aus dem Portfolio Ihres Unternehmens zu präsentieren, ein Produkt - **mehrere Botschaften**, viele verschiedene Werbebotschaften auf einem umweltfreundlichen Stift. Erstellen Sie einen individuellen Stift, der zu Ihrer Marke passt. **Stift aus recyceltem Material mit drehbarem Innenrohr**. Gehäuse und Zubehör transparent.

ES

**El tubo giratorio** en el interior le permite mostrar varias marcas de la cartera de su empresa, un producto - **varios mensajes**, muchos mensajes promocionales diferentes en un solo bolígrafo ecológico. Cree un bolígrafo perfectamente adaptado a su marca. **Bolígrafo de material reciclado con tubo interior giratorio**. Cuerpo y accesorios transparentes.

## Specification

|                   |             |                 |              |                 |             |                  |                                |                         |           |
|-------------------|-------------|-----------------|--------------|-----------------|-------------|------------------|--------------------------------|-------------------------|-----------|
| <b>Dimensions</b> | 11 x 143 mm | <b>Material</b> | Recycled ABS | <b>Finishes</b> | Transparent | <b>Ink color</b> | Blue, Black <i>(on demand)</i> | <b>Packaging (pcs.)</b> | 50 / 1000 |
|-------------------|-------------|-----------------|--------------|-----------------|-------------|------------------|--------------------------------|-------------------------|-----------|

## Branding options

### Clip

Digital overprint Side A

11 x 55 mm

Pad printing Side A

7 x 45 mm



### Barrel

Silkscreen printing 300° *(Standard)* All Side

30 x 45 mm

Silkscreen printing 300° XL *(On demand)* All Side

30 x 60 mm

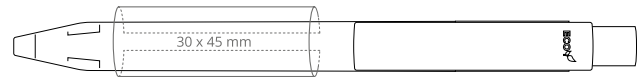

### Rotation tube

Silkscreen printing 300° *(Standard)*

30 x 45 mm

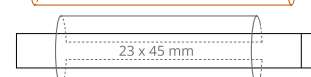

# DGT 360° Printing #creativity



Lecce Pen

table of contents

# DGT 360 ° Printing

#creativity

Moq 3 000 pcs.

check it out!

See how we make!



**FORTE**

Marking field: 34 x 110,3 mm

EU Production



**ZEN**

Marking field: 36 x 74 mm

EU Production



**TANTRA**

Marking field: 36 x 74 mm

**EN**

Personalize the entire barrel the way you want with DGT 360°.

**PL**

Personalizuj cały korpus tak jak chcesz z DGT 360°.

**IT**

Personalizzate l'intero serbatoio della vostra penna nel modo desiderato con la stampa in digitale a 360°.

**FR**

Personnalisez complètement le corps de votre stylo en quadri à 360°.

**DE**

Personalisieren Sie den gesamten Lauf mit DGT 360° so, wie Sie es wünschen.

**ES**

Personalice todo el cañón cuerpo quieras con impresión digital a 360°.

Product code: 191NFC

# ZEN NFC

## #technology

EU Production



01

120

05

08

10

126

132

18

135

136

139

35

See how  
we make  
and how  
it works!



check it out!

EN

ZEN NFC A pen that can do more! Designed to take full advantage of NFC - contactless and wireless communication technology. It is enough to scan the pen clip in a few seconds and **get access to publications, videos, pages, documents and many more saved under the link.**

PL

ZEN NFC Długopis, który potrafi więcej! Zaprojektowany, by w pełni wykorzystać możliwości NFC - bezdotykowej i bezprzewodowej technologii komunikacyjnej. Wystarczy parę sekund zeskanować klips długopisu i **otrzymać dostęp do zapisanych pod linkiem publikacji, filmów, stron, dokumentów i wielu innych.**

IT

ZEN NFC Una penna che può fare di più! Progettata per sfruttare appieno la tecnologia di comunicazione senza contatto e senza fili NFC. È sufficiente scansionare la clip della penna in pochi secondi **per avere accesso a pubblicazioni, video, pagine, documenti e molto altro ancora salvato sotto il link.**

FR

ZEN NFC Un stylo qui peut en faire plus ! Conçu pour tirer pleinement parti de la technologie de communication sans contact et sans fil NFC. Il suffit de scanner le clip du stylo en quelques secondes **pour accéder aux publications, vidéos, pages, documents et bien d'autres choses encore sauvegardées sous le lien.**

DE

ZEN NFC Der Stift, der mehr kann! Entwickelt, um die Vorteile von NFC - einer kontaktlosen und drahtlosen Kommunikationstechnologie - voll auszuschöpfen. Scannen Sie einfach den Clip des Stifts in wenigen Sekunden **und erhalten Sie Zugriff auf Publikationen, Videos, Seiten, Dokumente und vieles mehr, die unter dem Link gespeichert sind.**

ES

ZEN NFC ;Un bolígrafo que puede más! Diseñado para aprovechar al máximo la tecnología de comunicación inalámbrica y sin contacto NFC. Basta con escanear el clip del bolígrafo en unos segundos **y acceder a publicaciones, videos, páginas, documentos y mucho más guardados bajo el enlace.**

## Specification

|            |             |          |              |          |              |           |                         |                  |           |
|------------|-------------|----------|--------------|----------|--------------|-----------|-------------------------|------------------|-----------|
| Dimensions | 11 x 143 mm | Material | Recycled ABS | Finishes | Solid, Shiny | Ink color | Blue, Black (on demand) | Packaging (pcs.) | 50 / 1000 |
|------------|-------------|----------|--------------|----------|--------------|-----------|-------------------------|------------------|-----------|

## Branding options

### Clip

Digital overprint Side A  
Pad printing Side A

15 x 40 mm  
7 x 45 mm

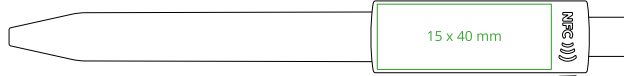
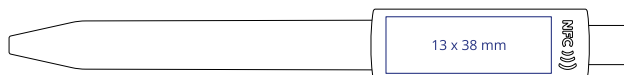

### Barrel

Digital overprint Side B,D  
Silkscreen printing 300° (Standard) All Side

7 x 75 mm  
30 x 45 mm



Silkscreen printing 300° XL (On demand) All Side

30 x 60 mm

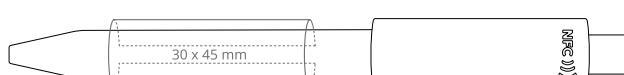

Product code: 191QR

# ZEN QR

## #technology

EU Production

check it out!



- 01
- 120
- 05
- 08
- 10
- 126
- 132
- 18
- 135
- 136
- 139
- 35

**EN**

ZEN QR A pen that can do more! Designed to take full advantage of QR - contactless and wireless communication technology. It is enough to scan the pen clip in a few seconds and **get access to publications, videos, pages, documents and many more saved under the link.**

**PL**

ZEN QR Długopis, który potrafi więcej! Zaprojektowany, by w pełni wykorzystać możliwości QR - bezdotykowej i bezprzewodowej technologii komunikacyjnej. Wystarczy parę sekund zeskanować klips długopisu i **otrzymać dostęp do zapisanych pod linkiem publikacji, filmów, stron, dokumentów i wielu innych.**

**IT**

ZEN QR Una penna che può fare di più! Progettata per sfruttare al meglio la tecnologia di comunicazione senza contatto e wireless QR. È sufficiente scansionare la clip della penna in pochi secondi **per avere accesso a pubblicazioni, video, pagine, documenti e molto altro ancora salvato sotto il link.**

**FR**

ZEN QR Un stylo qui peut en faire plus ! Conçu pour tirer pleinement parti de la technologie de communication sans contact et sans fil QR. Il suffit de scanner le clip du stylo en quelques secondes **pour accéder à des publications, des vidéos, des pages, des documents et bien d'autres choses encore sauvegardées sous le lien.**

**DE**

ZEN QR Der Stift, der mehr kann! Entwickelt, um die Vorteile von QR - einer kontaktlosen und drahtlosen Kommunikationstechnologie - voll auszuschöpfen. Scannen Sie einfach den Clip des Stifts in wenigen Sekunden und erhalten Sie Zugriff auf die **unter dem Link gespeicherten Publikationen, Videos, Seiten, Dokumente und vieles mehr.**

**ES**

ZEN QR ;Un bolígrafo que puede más! Diseñado para aprovechar al máximo la tecnología de comunicación inalámbrica y sin contacto QR. Basta con escanear el clip del bolígrafo en **unos segundos y acceder a publicaciones, vídeos, páginas, documentos y mucho más guardados bajo el enlace.**

## Specification

|                   |             |                 |     |                 |              |                  |                         |                         |           |
|-------------------|-------------|-----------------|-----|-----------------|--------------|------------------|-------------------------|-------------------------|-----------|
| <b>Dimensions</b> | 11 x 143 mm | <b>Material</b> | ABS | <b>Finishes</b> | Solid, Shiny | <b>Ink color</b> | Blue, Black (on demand) | <b>Packaging (pcs.)</b> | 50 / 1000 |
|-------------------|-------------|-----------------|-----|-----------------|--------------|------------------|-------------------------|-------------------------|-----------|

## Branding options

### Clip

- Digital overprint Side A
- Pad printing Side A

- 7 x 45 mm
- 7 x 45 mm

### Barrel

- Digital overprint Side B,D
- Silkscreen printing 300° (Standard) All Side
- Silkscreen printing 300° XL (On demand) All Side

- 5 x 75 mm
- 30 x 45 mm
- 30 x 65 mm

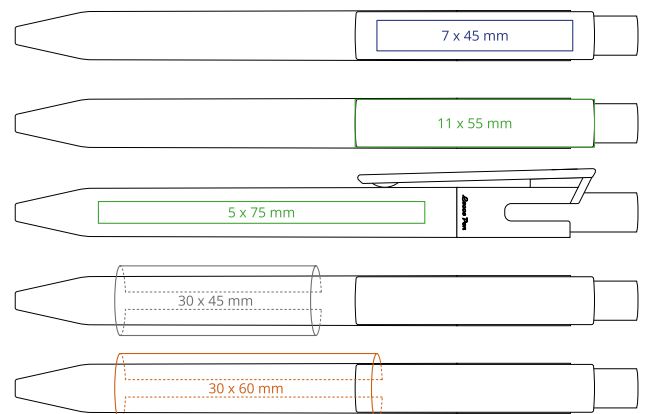



Lecce Pen

# TWIN Recycled Solid

#eco

check it out!



New

table of contents

Product code: 161R..

# TWIN Recycled

EU Production

## Colors



**01** PMS White    **120** PMS 012    **05** PMS 1585    **08** PMS 200    **10** PMS 227    **18** PMS 347    **132** PMS 368    **135** PMS 298    **136** PMS 2736    **35** PMS Black    **15** PMS 356

**EN**

**Twin** - our flagship pen about classical, italian design. Made from connection of beauty and functionality.

The pen is distinguished by the **ECO symbol** on the clip. **We believe in recycling.** We give a second life. We suport waste reduction. The product made of **recycled material** does not differ in properties and marking capabilities from standard ABS material, and they have a huge advantage they are **eco-friendly!** **Barrel and accessories in color,**

**PL**

**Twin** - flagowy model o klasycznym, włoskim designie. Stworzony z połączenia piękna i funkcjonalności. Długopis wyróżnia umieszczony na klipsie **symbol ECO.**

**Wierzmy w recykling.** Dajemy drugie życie. Wspieramy redukcję zalegających odpadów. Produkt z **recyklowanego materiału** nie odbiega właściwościami i możliwościami znakowania od standardowego materiału ABS, a mają ogromną zaletę - są **ekologiczne.** **Korpus i dodatki w kolorze.**

**IT**

**Twin** - la nostra penna di punta dal design classico e italiano. Realizzata grazie al connubio tra bellezza e funzionalità. La penna si distingue per il simbolo **ECO sulla clip.**

Crediamo nel riciclo. Diamo una seconda vita. Sosteniamo la riduzione dei rifiuti. **I prodotti realizzati** in materiale riciclato non differiscono per proprietà e capacità di marcatura dal mate-riale ABS standard e hanno un enorme vantaggio: **sono ecologici!** **Corpo, accessori della penna colorato,**

**FR**

**Twin** - notre stylo phare au design italien classique. Il est le résultat d'un mariage entre la beauté et la fonctionnalité. Le stylo se distingue par le **symbole ECO** sur le clip. **Nous croyons au recyclage.** Nous donnons une seconde vie. Nous soutenons la réduction des déchets.

Les produits fabriqués à partir de **matériaux recyclés** ne diffèrent pas, en termes de propriétés et de capacités de marquage, des matériaux ABS standard, et ils présentent un énorme avantage : **ils sont respectueux de l'environnement!** **Corps, accessoires du stylo en couleur.**

**DE**

**Twin** - das Vorzeigemodell mit klassischem italienischem Design. Geschaffen mit einer Kombination aus Schönheit und Funktionalität. Stift Variante zeichnet sich durch das **ECO-Symbol** auf dem Clip aus.

**We believe in recycling.** Wir schenken ein zweites Leben. Wir unterstützen die Reduzierung von Abfällen. Ein Produkt aus **recycletem Material** unterscheidet sich in seinen Eigenschaften und Markierungsmöglichkeiten nicht von Standard-ABS-Material und hat den großen Vorteil, dass es **ökologisch ist!** **Stiftgehäuse, Zubehörteile in Farbe.,**

**ES**

**Twin** - nuestro bolígrafo insignia de diseño clásico italiano. Una combinación de belleza y funcionalidad. La pluma variante se distingue por el **símbolo ECO** en el clip.

**Creemos en El bolígrafo se diferencia por.** Damos una segunda vida. Apoyamos la reducción de residuos. **Los productos fabricados con material reciclado** no difieren en propiedades y capacidad de marcado del material ABS estándar, y tienen una gran marcaje **son ecológicos!** **Cuerpo, accesorios del bolígrafo de color.**

**Sell - out!**

## Specification

|                   |            |                 |     |                 |              |                  |                         |                         |           |
|-------------------|------------|-----------------|-----|-----------------|--------------|------------------|-------------------------|-------------------------|-----------|
| <b>Dimensions</b> | 8 x 138 mm | <b>Material</b> | ABS | <b>Finishes</b> | Solid, Shiny | <b>Ink color</b> | Blue, Black (on demand) | <b>Packaging (pcs.)</b> | 50 / 1000 |
|-------------------|------------|-----------------|-----|-----------------|--------------|------------------|-------------------------|-------------------------|-----------|

## Branding options

### Clip

Pad printing Side A

5 x 28 mm

### Barrel

Digital overprint Side B,D

4 x 50 mm

Silkscreen printing 300° (Standard) All Side

25 x 50 mm

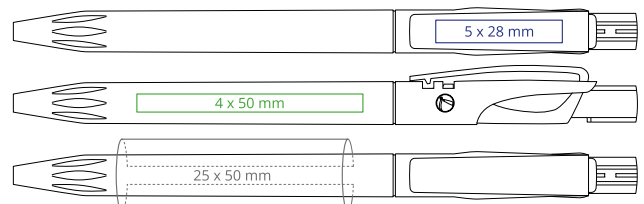





Lecce Pen

# TWIN Recycled White

#eco

check it out!



New

table of contents

Product code: 16101R..

# TWIN Recycled White

EU Production

## Colors

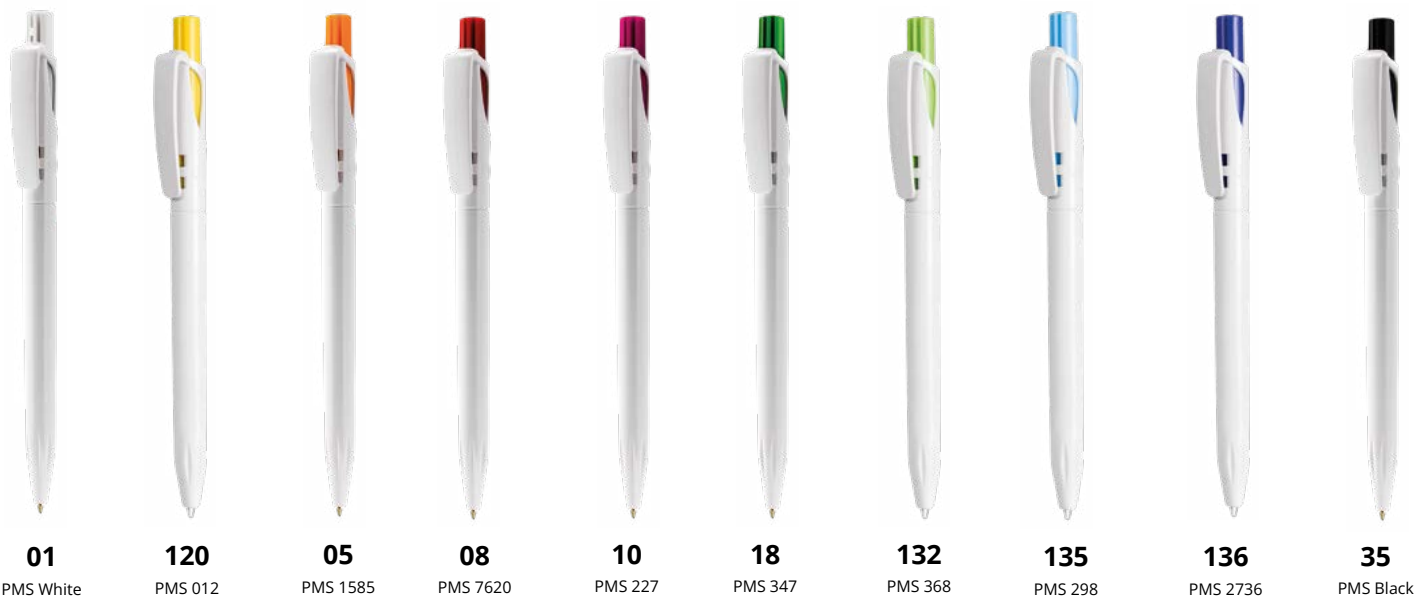

EN

**Twin** - our flagship pen about classical, italian design. White barrel. Made from connection of beauty and functionality.

The pen is distinguished by the **ECO symbol** on the clip. **We believe in recycling.** We give a second life. We suport waste reduction. The product made of **recycled material** does not differ in properties and marking capabilities from standard ABS material, and they have a huge advantage they are **eco-friendly!** Pen barrel in white, accessories in color.

PL

**Twin** - flagowy model o klasycznym, włoskim designie. Biały, z kolorowymi dodatkami i możliwością cyfrowego nadruku 360. Długopis wyróżnia umieszczony na klipsie **symbol ECO**.

**Wierzmy w recykling.** Dajemy drugie życie. Wspieramy redukcję zalegających odpadów. Produkt z **recyklowanego materiału** nie odbiega właściwościami i możliwościami znakowania od standardowego materiału ABS, a mają ogromną zaletę – są **ekologiczne**. Korpus długopisu biały, dodatki w kolorze.

IT

**Twin** - la nostra penna di punta dal design classico e italiano. Corpo bianco e accessori colorati. Realizzata in un connubio di bellezza e funzionalità. La penna si distingue per il **simbolo ECO sulla clip**. Crediamo nel riciclo. Diamo una seconda vita. Sosteniamo la riduzione dei rifiuti.

I **prodotti realizzati** in materiale riciclato non differiscono per proprietà e capacità di marcatura dal materiale ABS standard e hanno un enorme vantaggio: **sono ecologici!** **Corpo della penna bianco, accessori colorati.**

FR

**Twin** - notre stylo phare au design classique et italien. BCorpset accessoires colorés. Le mariage de la beauté et de la fonctionnalité. Le stylo se distingue par le **symbole ECO** sur le clip. **Nous croyons au recyclage.** Nous donnons une seconde vie. Nous soutenons la réduction des déchets.

Les produits fabriqués à partir de **matériaux recyclés** ne diffèrent pas, en termes de propriétés et de capacités de marquage, des matériaux ABS standard, et ils présentent un énorme avantage : **ils sont respectueux de l'environnement!** **Corps du stylo blanc, accessoires en couleur.**

DE

**Twin** - das Vorzeigemodell mit klassischem italienischem Design. Weiß, mit farbigem Zubehör. Stift Variante zeichnet sich durch das **ECO-Symbol** auf dem Clip aus.

**We believe in recycling.** Wir schenken ein zweites Leben. Wir unterstützen die Reduzierung von Abfällen. Ein Produkt aus **recyceltem Material** unterscheidet sich in seinen Eigenschaften und Markierungsmöglichkeiten nicht von Standard-ABS-Material und hat den großen Vorteil, dass es **ökologisch ist!** Stiftgehäuse in Weiß, Zubehörteile in Farbe.

ES

**Twin** - nuestro bolígrafo insignia de diseño clásico italiano. Cuerpo blanco y accesorios de color. Hecho de la conexión de la belleza y la funcionalidad. La pluma variante se distingue por el **símbolo ECO** en el clip. **Creemos en El bolígrafo se diferencia por.** Damos una segunda vida. Apoyamos la reducción de residuos.

Los productos fabricados con **material reciclado** no difieren en propiedades y capacidad de marcado del material ABS estándar, y tienen una gran marcaje **son ecológicos!** Cuerpo del bolígrafo blanco, accesorios de color.

## Specification

|                   |            |                 |     |                 |              |                  |                         |                         |           |
|-------------------|------------|-----------------|-----|-----------------|--------------|------------------|-------------------------|-------------------------|-----------|
| <b>Dimensions</b> | 8 x 138 mm | <b>Material</b> | ABS | <b>Finishes</b> | Solid, Shiny | <b>Ink color</b> | Blue, Black (on demand) | <b>Packaging (pcs.)</b> | 50 / 1000 |
|-------------------|------------|-----------------|-----|-----------------|--------------|------------------|-------------------------|-------------------------|-----------|

## Branding options

### Clip

Pad printing Side A

5 x 28 mm

### Barrel

Digital overprint Side B,D

4 x 50 mm

Silkscreen printing 300° (Standard) All Side

25 x 50 mm

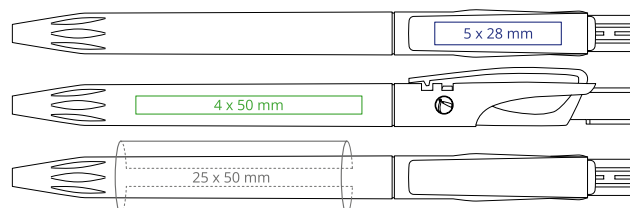



Lecce Pen

# ZEN

# Recycled Solid

#eco

check it out!



table of contents

Product code: 191R..

# ZEN Recycled

EU Production



## Colors

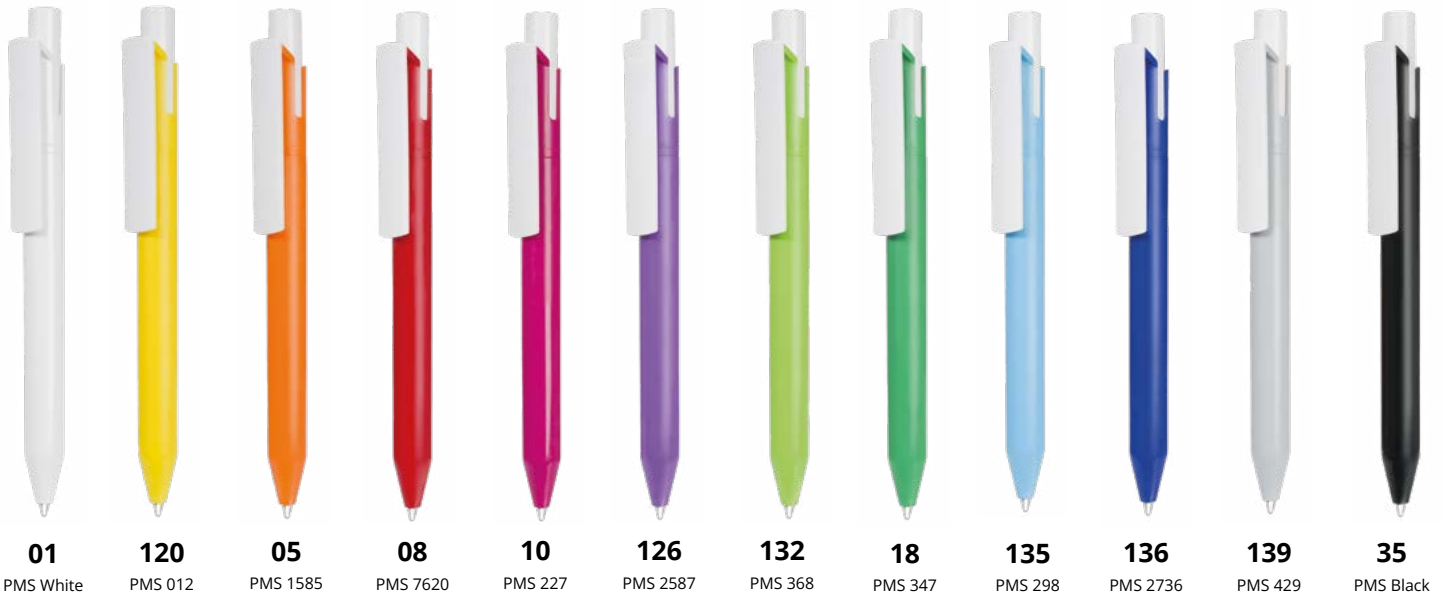

|  |  |  |   |  |   |
|--|--|--|---|--|---|
| <p><b>EN</b></p> <p>Pen made of R-ABS, recycled plastic from small household appliances and electronics.</p> <p>The pen is distinguished by the <b>ECO symbol</b> on the clip. <b>We believe in recycling.</b> We give a second life. We support waste reduction. The product made of <b>recycled material</b> does not differ in properties and marking capabilities from standard ABS material, and they have a huge advantage they are <b>eco-friendly!</b> Pen barrel in color, white accessories.</p> | <p><b>PL</b></p> <p>Długopis z R-ABS, recyklingu plastiku pochodzącego z małego AGD i elektroniki. Długopis wyróżnia umieszczony na klipsie symbol <b>ECO</b>.</p> <p><b>Wierzmy w recykling.</b> Dajemy drugie życie. Wspieramy redukcję zalegających odpadów. Produkt z <b>recyklowanego materiału</b> nie odbiega właściwościami i możliwościami znakowania od standardowego materiału ABS, a mają ogromną zaletę – są <b>ekologiczne</b>. Korpus długopisu w kolorze, dodatki białe.</p> | <p><b>IT</b></p> <p>Penna realizzata in R-ABS, plastica riciclata da piccoli elettrodomestici ed elettronica. La penna si distingue per il simbolo <b>ECO</b> sulla clip. Crediamo nel riciclo. Diamo una seconda vita. Sosteniamo la riduzione dei rifiuti.</p> <p><b>I prodotti realizzati</b> in materiale riciclato non differiscono per proprietà e capacità di marcatura dal materiale ABS standard e hanno un enorme vantaggio: <b>sono ecologici!</b> Corpo della penna colorato, accessori bianchi.</p> | <p><b>FR</b></p> <p>Stylo en R-ABS, plastique recyclé provenant de petits appareils ménagers et électroniques. Le stylo se distingue par le <b>symbole ECO</b> sur le clip. <b>Nous croyons au recyclage.</b> Nous donnons une seconde vie. Nous soutenons la réduction des déchets.</p> <p>Les produits fabriqués à partir de <b>matériaux recyclés</b> ne diffèrent pas, en termes de propriétés et de capacités de marquage, des matériaux ABS standard, et ils présentent un énorme avantage : <b>ils sont respectueux de l'environnement!</b> Corps du stylo en couleur, accessoires blancs.</p> | <p><b>DE</b></p> <p>Ein Stift aus R-ABS, dem Recycling von Kunststoffen aus kleinen Haushaltsgeräten und Elektronik. Stift Variante zeichnet sich durch das <b>ECO-Symbol</b> auf dem Clip aus.</p> <p><b>We believe in recycling.</b> Wir schenken ein zweites Leben. Wir unterstützen die Reduzierung von Abfällen. Ein Produkt aus <b>recyceltem Material</b> unterscheidet sich in seinen Eigenschaften und Markierungsmöglichkeiten nicht von Standard-ABS-Material und hat den großen Vorteil, dass es <b>ökologisch ist!</b> Stiftgehäuse in Farbe, weiße Zubehörteile.</p> | <p><b>ES</b></p> <p>Bolígrafo fabricado con R-ABS, plástico reciclado de pequeños electrodomésticos y aparatos electrónicos. La pluma variante se distingue por el <b>símbolo ECO</b> en el clip. <b>Creemos en El bolígrafo se diferencia por.</b> Damos una segunda vida. Apoyamos la reducción de residuos.</p> <p>Los productos fabricados con <b>material reciclado</b> no difieren en propiedades y capacidad de marcado del material ABS estándar, y tienen una gran marcaje <b>son ecológicos!</b> Cuerpo del bolígrafo de color, accesorios blancos.</p> |
|--|--|--|---|--|---|

## Specification

|            |             |          |              |          |       |           |                         |                  |           |
|------------|-------------|----------|--------------|----------|-------|-----------|-------------------------|------------------|-----------|
| Dimensions | 11 x 143 mm | Material | Recycled ABS | Finishes | Solid | Ink color | Blue, Black (on demand) | Packaging (pcs.) | 50 / 1000 |
|------------|-------------|----------|--------------|----------|-------|-----------|-------------------------|------------------|-----------|

## Branding options

### Clip

- Digital overprint Side A
- Pad printing Side A

11 x 55 mm  
7 x 45 mm

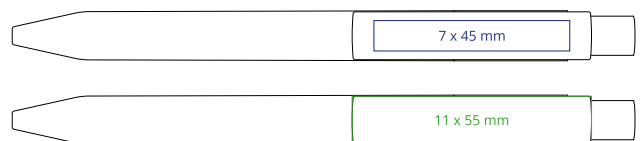

### Barrel

- Digital overprint Side B,D
- Silkscreen printing 300° (Standard) All Side
- Silkscreen printing 300° XL (On demand) All Side

5 x 75 mm  
30 x 45 mm  
30 x 60 mm

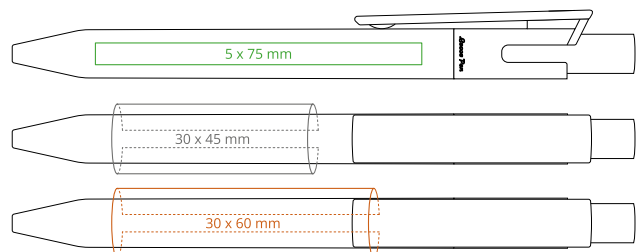



Lecce Pen

# ZEN Recycled White

#eco

check it out!



table of contents

Product code: 19101R..

# ZEN Recycled White

EU Production

## Colors

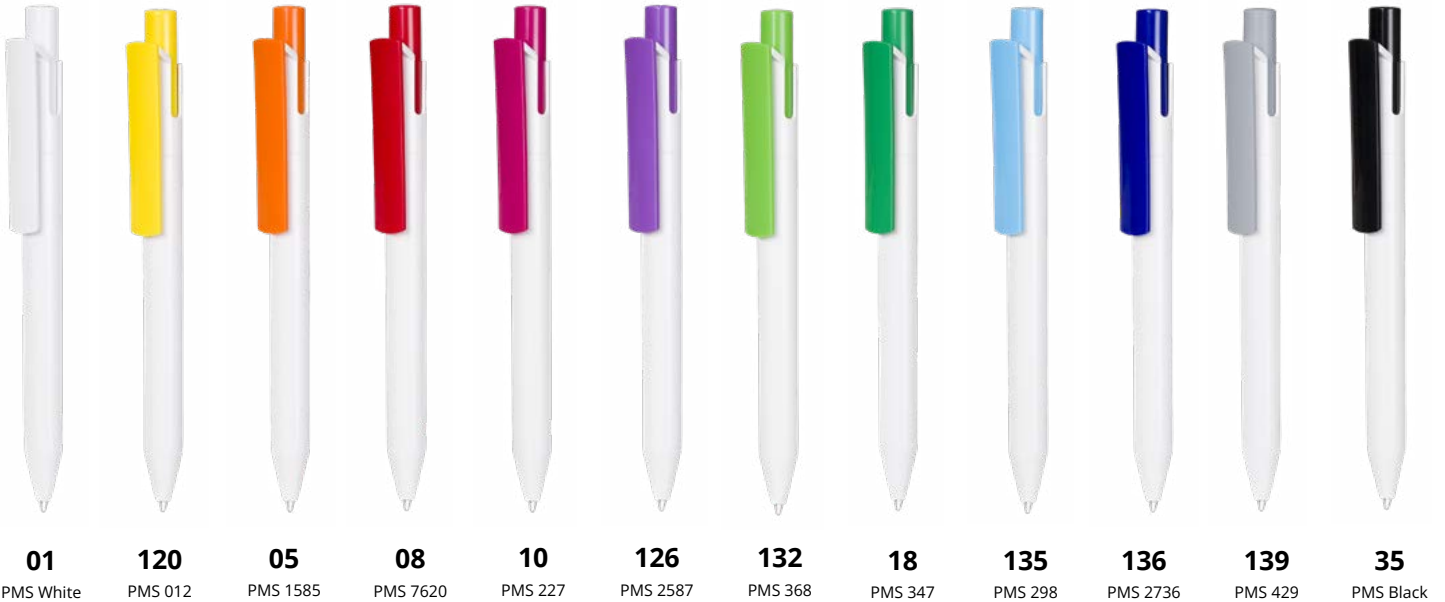

|  |  |  |   |   |   |
|--|--|--|---|---|---|
| <p><b>EN</b></p> <p><b>Zen White</b> plastic pen, white barrel, top and clip colored, blue ink.</p> <p>The pen is distinguished by the <b>ECO symbol</b> on the clip. <b>We believe in recycling.</b> We give a second life. We support waste reduction. The product made of <b>recycled material</b> does not differ in properties and marking capabilities from standard ABS material, and they have a huge advantage they are <b>eco-friendly!</b> Pen barrel in white, accessories in color.</p> | <p><b>PL</b></p> <p>Prostota i równowaga. Długopis <b>ZEN</b> to ogrom możliwości kolorystycznych i serwisowych. Długopis wyróżnia umieszczony na klipsie <b>symbol ECO</b>.</p> <p><b>Wierzmy w recykling.</b> Dajemy drugie życie. Wspieramy redukcję zalegających odpadów. Produkt z <b>recyklowanego materiału</b> nie odbiega właściwościami i możliwościami znakowania od standardowego materiału ABS, a mają ogromną zaletę – są <b>ekologiczne</b>. Korpus długopisu biały, dodatki w kolorze.</p> | <p><b>IT</b></p> <p><b>Zen Penna</b> in plastica bianca, fusto bianco, parte superiore e clip colorate, inchiostro blu. La penna si distingue per il simbolo <b>ECO</b> sulla clip. Crediamo nel riciclo. Diamo una seconda vita. Sosteniamo la riduzione dei rifiuti.</p> <p>I prodotti realizzati in <b>materiale riciclato</b> non differiscono per proprietà e capacità di marcatura dal materiale ABS standard e hanno un enorme vantaggio: <b>sono ecologici!</b> <b>Corpo della penna bianco, accessori colorati.</b></p> | <p><b>FR</b></p> <p><b>Stylo Zen</b> en plastique blanc, corps blanc, capuchon et clip colorés, encre bleue. Le stylo se distingue par le <b>symbole ECO</b> sur le clip. <b>Nous croyons au recyclage.</b> Nous donnons une seconde vie. Nous soutenons la réduction des déchets.</p> <p>Les produits fabriqués à partir de <b>matériaux recyclés</b> ne diffèrent pas, en termes de propriétés et de capacités de marquage, des matériaux ABS standard, et ils présentent un énorme avantage : <b>ils sont respectueux de l'environnement!</b> <b>Corps du stylo blanc, accessoires en couleur.</b></p> | <p><b>DE</b></p> <p>Einfachheit und Ausgewogenheit. Der <b>ZEN-Stift</b> bietet eine Fülle von Farb- und Servicemöglichkeiten. Der Stift Variante zeichnet sich durch das <b>ECO-Symbol</b> auf dem Clip aus.</p> <p><b>We believe in recycling.</b> Wir schenken ein zweites Leben. Wir unterstützen die Reduzierung von Abfällen. Ein Produkt aus <b>recyceltem Material</b> unterscheidet sich in seinen Eigenschaften und Markierungsmöglichkeiten nicht von Standard-ABS-Material und hat den großen Vorteil, dass es <b>ökologisch ist!</b> <b>Stiftgehäuse in Weiß, Zubehörteile in Farbe.</b></p> | <p><b>ES</b></p> <p><b>Zen Bolígrafo</b> de plástico blanco, cuerpo blanco, parte superior y clip de color, tinta azul. La pluma variante se distingue por el <b>símbolo ECO</b> en el clip. <b>Creemos en El bolígrafo se diferencia por.</b> Damos una segunda vida. Apoyamos la reducción de residuos.</p> <p>Los productos fabricados con <b>materiale riciclado</b> no difieren en propiedades y capacidad de marcado del material ABS estándar, y tienen una gran marcaje <b>son ecológicos!</b> <b>Cuerpo del bolígrafo blanco, accesorios de color.</b></p> |
|--|--|--|---|---|---|

## Specification

|                   |             |                 |     |                 |              |                  |                         |                         |           |
|-------------------|-------------|-----------------|-----|-----------------|--------------|------------------|-------------------------|-------------------------|-----------|
| <b>Dimensions</b> | 11 x 143 mm | <b>Material</b> | ABS | <b>Finishes</b> | Solid, Shiny | <b>Ink color</b> | Blue, Black (on demand) | <b>Packaging (pcs.)</b> | 50 / 1000 |
|-------------------|-------------|-----------------|-----|-----------------|--------------|------------------|-------------------------|-------------------------|-----------|

## Branding options

### Clip

- Digital overprint Side A
- Pad printing Side A

11 x 55 mm  
7 x 45 mm

### Barrel

- Digital overprint Side B,D
- Silkscreen printing 300° (Standard) All Side
- Silkscreen printing 300° XL (On demand) All Side

5 x 75 mm  
30 x 45 mm  
30 x 60 mm

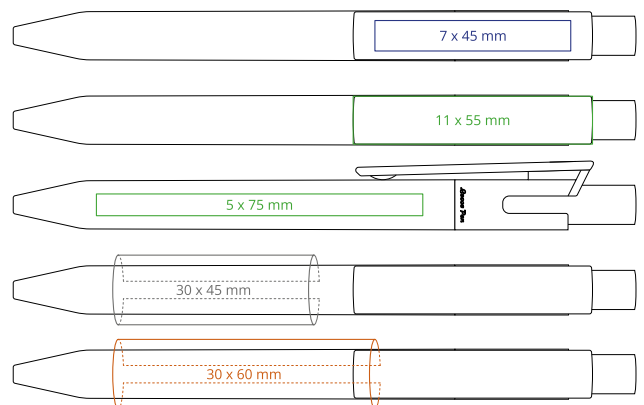



Lecce Pen

# ZEN

# Bio

#eco

check it out!



table of contents

Product code: 191B..W

# ZEN Bio

EU Production

## Colors



**01**  
PMS White



**03**  
PMS 7409



**08**  
PMS 7620



**15**  
PMS 356



**24**  
PMS 301



**35**  
PMS Black

**EN**  
GreenLine pens are produced with a **new bioplastic of natural origin**: born from renewable resources of agricultural origin (non genetically modified **corn or potato starch**)

and return to the earth through biodegradation and/or composting processes **without releasing polluting substances** (also the dyes used are biodegradable). The pens produced with this new bioplastic (except refill and spring) are **100% biodegradable** responding to the demand for consumer products with low environmental impact.

**PL**  
Długopisy z kolekcji **green** są produkowane z nowego **bioplastiku** pochodzenia naturalnego: stworzone z odnawialnych zasobów pochodzenia rolniczego, typu **skrobia kukurydziana, ziemniaczana**.

Powracają do obiegu poprzez biodegradację i/lub proces kompostowania **bez uwalniania szkodliwych substancji**. Długopisy produkowane z użyciem nowego bioplastiku (wyłączając wkład i sprężynkę) są w **100% biodegradowalne** w odpowiedzi na popyt na produkty o niskim wpływie na środowisko.

**IT**  
Le penne **GreenLine** sono prodotte con una **nuova bioplastica** di origine naturale: nasce da risorse rinnovabili di origine agricola (**amido di mais o di patate non geneticamente modificate**)

e ritornano alla terra attraverso processi di biodegradazione e/o compostaggio **senza rilasciare sostanze inquinanti** (anche i coloranti utilizzati sono biodegradabili). Le penne prodotte con questa nuova bioplastica (tranne il refill e la molla) sono biodegradabili al **100% e rispondono alla domanda** di prodotti di consumo a basso impatto ambientale.

**FR**  
Les stylos **GreenLine** sont produits avec un **nouveau bioplastique** d'origine naturelle : né de ressources renouvelables d'origine agricole (**amidon de maïs ou de pomme de terre non génétiquement modifié**)

et retournent à la terre par des processus de biodégradation et/ou de compostage **sans libérer de substances polluantes** (les colorants utilisés sont également biodégradables). Les stylos produits avec ce nouveau bioplastique (à l'exception de la recharge et du ressort) sont **100% biodégradables**, ce qui répond à la demande de produits de consommation à faible impact sur l'environnement.

**DE**  
**GreenLine-Stifte** werden mit einem neuen **Biokunststoff natürlichen Ursprungs** hergestellt: aus erneuerbaren Ressourcen landwirtschaftlichen Ursprungs (**nicht genetisch veränderte Mais- oder Kartoffelstärke**)

durch biologischen Abbau und/oder Kompostierung in die Erde zurückkehren, **ohne dabei Schadstoffe freizusetzen** (auch die verwendeten Farbstoffe sind biologisch abbaubar). Die mit diesem neuen Biokunststoff hergestellten Stifte (außer Mine und Feder) sind zu **100% biologisch** abbaubar und entsprechen damit der Nachfrage nach Konsumgütern mit geringer Umweltbelastung.

**ES**  
Los **bolígrafos GreenLine** se producen con un nuevo bioplástico de origen natural: nace de recursos renovables de origen agrícola (**almidón de maíz o patata no modificados genéticamente**)

y vuelven a la tierra mediante procesos de biodegradación y/o compostaje sin liberar **sustancias contaminantes** (también los tintes utilizados son biodegradables). Los bolígrafos fabricados con este nuevo bioplástico (excepto el recambio y el muelle) son **100% biodegradables**, respondiendo así a la demanda de productos de consumo con bajo impacto medioambiental.

## Specification

|                   |             |                 |           |                 |       |                  |                         |                         |           |
|-------------------|-------------|-----------------|-----------|-----------------|-------|------------------|-------------------------|-------------------------|-----------|
| <b>Dimensions</b> | 11 x 143 mm | <b>Material</b> | Bioplast® | <b>Finishes</b> | Solid | <b>Ink color</b> | Blue, Black (on demand) | <b>Packaging (pcs.)</b> | 50 / 1000 |
|-------------------|-------------|-----------------|-----------|-----------------|-------|------------------|-------------------------|-------------------------|-----------|

## Branding options

### Clip

Digital overprint Side A

7 x 45 mm

Pad printing Side A

7 x 45 mm

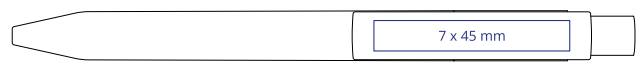

### Barrel

Digital overprint Side B,D

7 x 75 mm

Silkscreen printing 300° (Standard) All Side

30 x 45 mm

Silkscreen printing 300° XL (On demand) All Side

30 x 60 mm

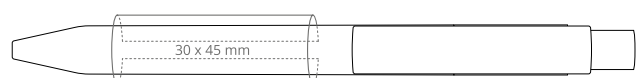





Lecce Pen

# FORTE Recycled

#eco

check it out!

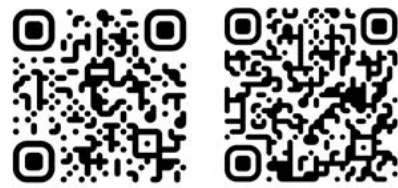

See how  
we make!

table of contents

Product code: 605R..W

# FORTE Recycled

EU Production

## Colors





|                        |                       |                       |                       |                      |                        |                       |                      |                       |                        |                       |                        |
|------------------------|-----------------------|-----------------------|-----------------------|----------------------|------------------------|-----------------------|----------------------|-----------------------|------------------------|-----------------------|------------------------|
| <b>01</b><br>PMS White | <b>120</b><br>PMS 012 | <b>05</b><br>PMS 1585 | <b>08</b><br>PMS 7620 | <b>10</b><br>PMS 227 | <b>126</b><br>PMS 2587 | <b>132</b><br>PMS 368 | <b>18</b><br>PMS 347 | <b>135</b><br>PMS 298 | <b>136</b><br>PMS 2736 | <b>139</b><br>PMS 429 | <b>35</b><br>PMS Black |
|------------------------|-----------------------|-----------------------|-----------------------|----------------------|------------------------|-----------------------|----------------------|-----------------------|------------------------|-----------------------|------------------------|

|   |   |   |   |   |  |
|---|---|---|---|---|--|
| <p><b>EN</b></p> <p>The pen is distinguished by the <b>ECO symbol</b> on the clip.</p> <p><b>We believe in recycling.</b> We give a second life. We support waste reduction. The product made of <b>recycled material</b> does not differ in properties and marking capabilities from standard ABS material, and they have a huge advantage they are <b>eco-friendly!</b></p> <p><b>Pen barrel in color, white accessories.</b></p> | <p><b>PL</b></p> <p>Długopis wyróżnia umieszczony na klipsie <b>symbol ECO</b>.</p> <p><b>Wierzmy w recykling.</b> Dajemy drugie życie. Wspieramy redukcję zalegających odpadów. Produkt z <b>recyklowanego materiału</b> nie odbiega właściwościami i możliwościami znakowania od standardowego materiału ABS, a mają ogromną zaletę – są <b>ekologiczne</b>.</p> <p><b>Korpus długopisu w kolorze, dodatki białe.</b></p> | <p><b>IT</b></p> <p>La penna si distingue per il simbolo <b>ECO</b> sulla clip.</p> <p>Crediamo nel riciclo. Diamo una seconda vita. Sosteniamo la riduzione dei rifiuti.</p> <p>I prodotti realizzati in <b>materiale riciclato</b> non differiscono per proprietà e capacità di marcatura dal materiale ABS standard e hanno un enorme vantaggio: <b>sono ecologici!</b></p> <p><b>Corpo della penna colorato, accessori bianchi.</b></p> | <p><b>FR</b></p> <p>Le stylo se distingue par le <b>symbole ECO</b> sur le clip.</p> <p><b>Nous croyons au recyclage.</b> Nous donnons une seconde vie. Nous soutenons la réduction des déchets.</p> <p>Les produits fabriqués à partir de <b>matériaux recyclés</b> ne diffèrent pas, en termes de propriétés et de capacités de marquage, des matériaux ABS standard, et ils présentent un énorme avantage : <b>ils sont respectueux de l'environnement!</b></p> <p><b>Corps du stylo en couleur, accessoires blancs.</b></p> | <p><b>DE</b></p> <p>der Stift Variante zeichnet sich durch das <b>ECO-Symbol</b> auf dem Clip aus.</p> <p><b>We believe in recycling.</b> Wir schenken ein zweites Leben. Wir unterstützen die Reduzierung von Abfällen. Ein Produkt aus <b>recyceltem Material</b> unterscheidet sich in seinen Eigenschaften und Markierungsmöglichkeiten nicht von Standard-ABS-Material und hat den großen Vorteil, dass es <b>ökologisch ist!</b></p> <p><b>Stiftgehäuse in Farbe, weiße Zubehörteile.</b></p> | <p><b>ES</b></p> <p>La pluma variante se distingue por el <b>símbolo ECO</b> en el clip.</p> <p><b>Creemos en El bolígrafo se diferencia por.</b> Damos una segunda vida. Apoyamos la reducción de residuos.</p> <p>Los productos fabricados con <b>materiale reciclado</b> no difieren en propiedades y capacidad de marcado del material ABS estándar, y tienen una gran marcaje <b>son ecológicos!</b></p> <p><b>Cuerpo del bolígrafo de color, accesorios blancos.</b></p> |
|---|---|---|---|---|--|

## Specification

|                   |             |                 |              |                 |              |                  |                         |                         |           |
|-------------------|-------------|-----------------|--------------|-----------------|--------------|------------------|-------------------------|-------------------------|-----------|
| <b>Dimensions</b> | 10 x 139 mm | <b>Material</b> | Recycled ABS | <b>Finishes</b> | Solid, Shiny | <b>Ink color</b> | Blue, Black (on demand) | <b>Packaging (pcs.)</b> | 50 / 1000 |
|-------------------|-------------|-----------------|--------------|-----------------|--------------|------------------|-------------------------|-------------------------|-----------|

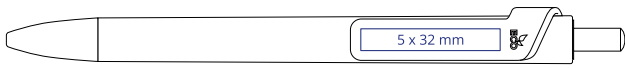
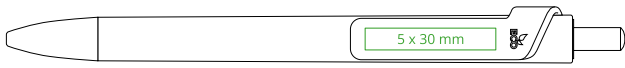
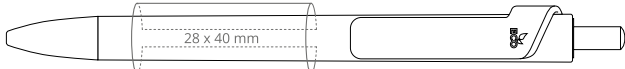
## Branding options

|  |                                     |   |
|--|-------------------------------------|---|
| <p><b>Clip</b></p> <p>Digital overprint Side A</p> <p>Pad printing Side A</p>  | <p>5 x 30 mm</p> <p>5 x 32 mm</p>   |   |
| <p><b>Barrel</b></p> <p>Silkscreen printing 300° (Standard) All Side</p> <p>Silkscreen printing 300° XL (On demand) All Side</p> | <p>28 x 40 mm</p> <p>28 x 60 mm</p> |   |



# FORTE Bio

#eco

check it out!

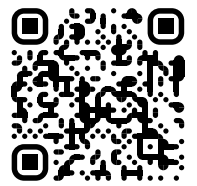

Available in  
version  
SafeTouch



Lecce Pen

table of contents

Product code: 603MB..W

# FORTE Bio

EU Production

## Colors

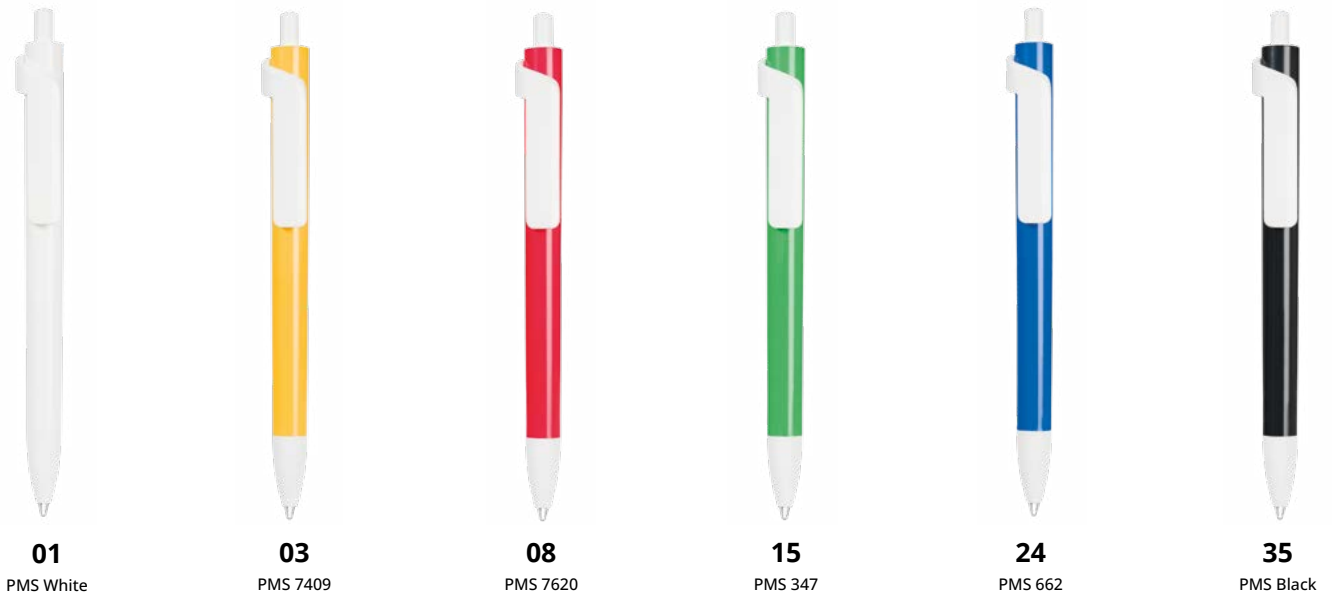

|   |   |  |   |   |   |
|---|---|--|---|---|---|
| <p><b>EN</b></p> <p>GreenLine pens are produced with a <b>new bioplastic of natural origin</b>: born from renewable resources of agricultural origin (non genetically modified corn or potato starch)</p> <p>Return to the earth through biodegradation and/or composting <b>processes without releasing polluting substances</b> (also the dyes used are biodegradable). The pens produced with this new bioplastic (except refill and spring) are <b>100% biodegradable</b> responding to the demand for consumer products with low environmental impact.</p> | <p><b>PL</b></p> <p>Długopisy z kolekcji „green” są produkowane z <b>nowego bioplastiku pochodzenia naturalnego</b>: stworzone z odnawialnych zasobów pochodzenia rolniczego, typu skrobia kukurydziana, ziemniaczana.</p> <p>Powracają do obiegu poprzez biodegradację i/lub proces kompostowania <b>bez uwalniania szkodliwych substancji</b>. Długopisy produkowane z użyciem nowego bioplastiku (wyłączając wkład i sprężynkę) są w <b>100% biodegradowalne</b> w odpowiedzi na popyt na produkty o niskim wpływie na środowisko.</p> | <p><b>IT</b></p> <p>Le penne <b>GreenLine</b> sono prodotte con una <b>nuova bioplastica di origine naturale</b>: nasce da risorse rinnovabili di origine agricola (<b>amido di mais o di patate non geneticamente modificate</b>) e ritornano alla terra <b>attraverso processi di biodegradazione e/o compostaggio</b> senza rilasciare sostanze inquinanti (anche i coloranti utilizzati sono biodegradabili). Le penne prodotte con questa nuova bioplastica (tranne il refill e la molla) sono biodegradabili al <b>100% e rispondono</b> alla domanda di prodotti di consumo a basso impatto ambientale.</p> | <p><b>FR</b></p> <p>Les stylos <b>GreenLine</b> sont produits avec un <b>nouveau bioplastique d'origine naturelle</b>: né de ressources renouvelables d'origine agricole (<b>amidon de maïs ou de pomme de terre non génétiquement modifié</b>) et retournant à la terre par des processus de biodégradation</p> <p>et/ou de <b>compostage sans libérer de substances polluantes</b> (les colorants utilisés sont également biodégradables). Les stylos produits avec ce nouveau bioplastique (à l'exception de la recharge et du ressort) sont <b>100% biodégradables</b>, ce qui répond à la demande de produits de consommation à faible impact sur l'environnement.</p> | <p><b>DE</b></p> <p>Die Stifte der „grünen” Kollektion bestehen <b>aus einem neuen Biokunststoff natürlichen Ursprungs</b>, der aus erneuerbaren Ressourcen landwirtschaftlichen Ursprungs wie Mais- und Kartoffelstärke hergestellt wird.</p> <p>Sie werden durch biologischen Abbau und/oder <b>einen Kompostierungsprozess recycelt</b>, ohne Schadstoffe freizusetzen (auch die verwendeten Pigmente sind biologisch abbaubar). Die aus dem neuen Biokunststoff hergestellten Stifte (mit Ausnahme der Mine und der Feder) sind zu <b>100 % biologisch</b> abbaubar und entsprechen damit der Nachfrage nach Produkten mit geringen Umweltauswirkungen.</p> | <p><b>ES</b></p> <p>Los bolígrafos <b>GreenLine</b> se producen con un <b>nuevo bioplástico de origen natural</b>: <b>nace</b> de recursos renovables de origen agrícola (<b>almidón de maíz o patata no modificados genéticamente</b>) y vuelve a <b>la tierra mediante procesos de biodegradación y/o compostaje</b> sin liberar sustancias contaminantes (también los tintes utilizados son biodegradables). Los bolígrafos fabricados con este nuevo bioplástico (excepto el recambio y el muelle) son <b>100% biodegradables</b>, respondiendo así a la demanda de productos de consumo con bajo impacto medioambiental.</p> |
|---|---|--|---|---|---|

## Specification

|                   |             |                 |           |                 |              |                  |                         |                         |           |
|-------------------|-------------|-----------------|-----------|-----------------|--------------|------------------|-------------------------|-------------------------|-----------|
| <b>Dimensions</b> | 10 x 139 mm | <b>Material</b> | Bioplast® | <b>Finishes</b> | Solid, Shiny | <b>Ink color</b> | Blue, Black (on demand) | <b>Packaging (pcs.)</b> | 50 / 1000 |
|-------------------|-------------|-----------------|-----------|-----------------|--------------|------------------|-------------------------|-------------------------|-----------|

## Branding options

**Clip**

- Digital overprint Side A: 5 x 30 mm
- Pad printing Side A: 5 x 32 mm

**Barrel**

- Silkscreen printing 300° (Standard) All Side: 28 x 42 mm
- Silkscreen printing 300° XL (On demand) All Side: 30 x 60 mm



# FORTE Recycled SafeTouch

*#eco #antibacterial*

*check it out!*



*table of contents*

Product code: 604RST..

# FORTE Recycled SafeTouch

EU Production



## Colors



**01**

PMS White



**102**

PMS 712



**103**

PMS 705



**105**

PMS 628



**106**

PMS 290



**139**

PMS 429

**EN**

Pen made of recycled plastic, antibacterial.

The pen is distinguished by the ECO symbol on the clip.

**PL**

Długopis z plastiku z recyklingu, antybakteryjny.

Długopis wyróżnia się symbolem ECO na klipsie.

**IT**

Penna in plastica riciclata, antibatterica.

La penna si distingue per il simbolo ECO sul clip.

**FR**

Stylo en plastique recyclé, antibactérien.

Le stylo se distingue par le symbole ECO sur le clip.

**DE**

Kugelschreiber aus recyceltem Kunststoff, antibakteriell.

Der Kugelschreiber zeichnet sich durch das ECO-Symbol auf dem Clip aus.

**ES**

Bolígrafo de plástico reciclado, antibacteriano.

El bolígrafo se distingue por el símbolo ECO en el clip.

## Specification

|                   |             |                 |  |                 |              |                  |                         |                         |           |
|-------------------|-------------|-----------------|--|-----------------|--------------|------------------|-------------------------|-------------------------|-----------|
| <b>Dimensions</b> | 10 x 139 mm | <b>Material</b> | Recycled ABS with antibacterial additive | <b>Finishes</b> | Solid, Shiny | <b>Ink color</b> | Blue, Black (on demand) | <b>Packaging (pcs.)</b> | 50 / 1000 |
|-------------------|-------------|-----------------|--|-----------------|--------------|------------------|-------------------------|-------------------------|-----------|

## Branding options

### Clip

Digital overprint Side A

Pad printing Side A

5 x 30 mm

5 x 32 mm

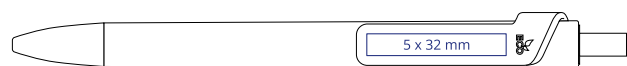

### Barrel

Silkscreen printing 300° (Standard) All Side

Silkscreen printing 300° XL (On demand) All Side

28 x 40 mm

28 x 60 mm

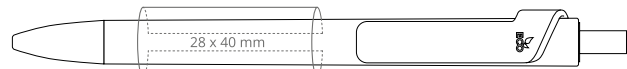



Lecce Pen

# RE-PEN Push New

#eco

check it out!



table of contents

Product code: 103EW..

# RE-PEN Push New



EU Production

## Colors

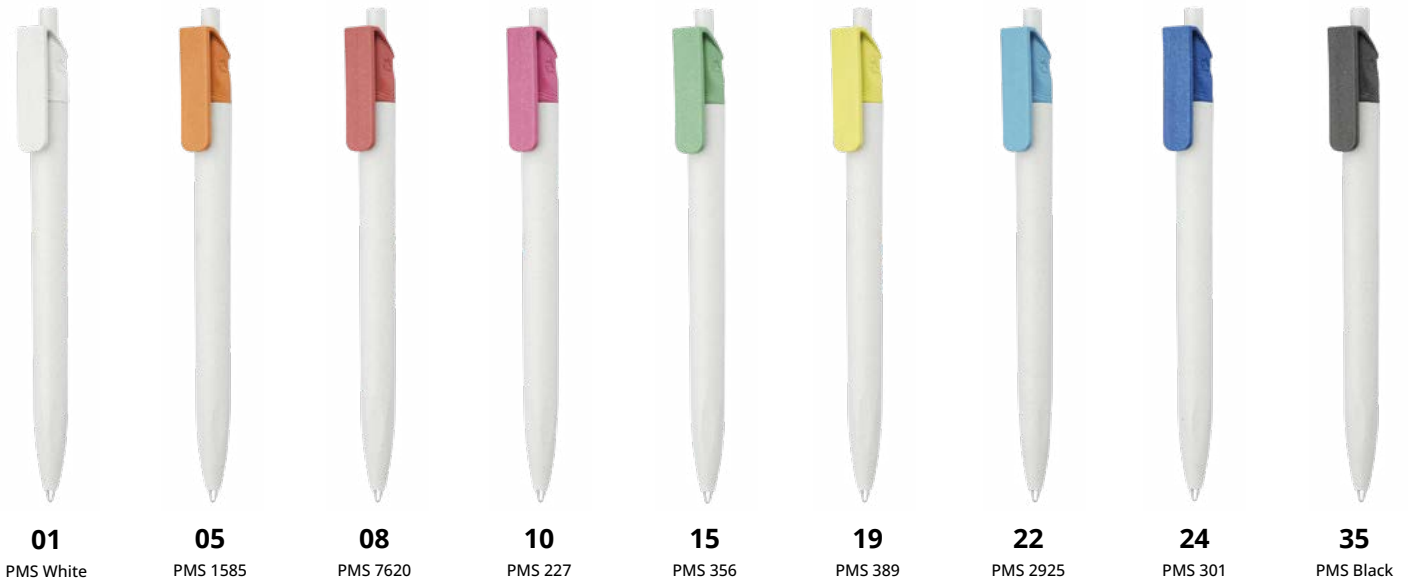

### EN

**EcoLine** is a line of writing instruments made in a **special material** coming from the **recycling of beverage cartons**. Beverage cartons are in fact composed of several layers: cellulose, polyethylene and aluminum. After a first processing for the recovery of cellulose, the fraction of polyethylene and aluminum is further processed to generate a new second raw material. **This recycled material has a very particular aesthetic aspect** (thanks to the presence of aluminum together with the plastic component) which distinguishes it from any other on the market.

### PL

**EcoLine** - długopisy z **recyklingu kartoników** po napojach. Kartoniki te wykonane są z kilku warstw: celulozy, polietylenu i aluminium. Po pierwszym etapie odzyskiwania celulozy frakcja polietylenu i aluminium jest dalej przetwarzana w celu wytworzenia nowego surowca. **Uzyskany w ten sposób materiał posiada bardzo szczególną wartość estetyczną** (dzięki obecności aluminium połączonego z plastikiem), która wyróżnia go spośród innych obecnych na rynku materiałów.

### IT

**EcoLine** è una linea di strumenti di scrittura realizzati in uno **speciale materiale proveniente dal riciclo dei cartoni** per bevande. I cartoni per bevande sono infatti composti da diversi strati: cellulosa, polietilene e alluminio. Dopo una prima lavorazione per il recupero della cellulosa, la frazione di polietilene e alluminio viene ulteriormente lavorata per generare una nuova materia prima seconda. **Questo materiale riciclato ha un aspetto estetico molto particolare** (grazie alla presenza dell'alluminio insieme alla componente plastica) che lo distingue da qualsiasi altro sul mercato.

### FR

**EcoLine** est une ligne d'instruments d'écriture fabriqués dans un **matériau spécial issu du recyclage des briques** à boisson. Les briques de boissons sont en effet composées de boissons couchées : cellulose, polyéthylène et aluminium. Après un premier traitement pour la récupération de la cellulose, la fraction de polyéthylène et d'aluminium est transformée pour générer une nouvelle matière première. **Ce matériau recyclé a un aspect esthétique très particulier** (grâce à la présence de l'aluminium avec la composante plastique) qui le distingue de tous les autres sur le marché.

### DE

**EcoLine** - Stifte aus recycelten Getränkekartons. **Diese Kartons** bestehen aus mehreren Schichten: Zellulose, Polyethylen und Aluminium. Nach der ersten Stufe der Zellstoffrückgewinnung wird die Polyethylen- und Aluminiumfraktion weiterverarbeitet, um ein neues Rohmaterial herzustellen. **Das daraus resultierende Material hat einen ganz besonderen ästhetischen Wert** (dank des Aluminiums in Kombination mit Kunststoff), der es von anderen Materialien auf dem Markt unterscheidet.

### ES

**EcoLine** es una línea de instrumentos de escritura fabricados con un **material especial procedente del reciclado de cartones de bebidas**. De hecho, los cartones de bebidas se componen de varias capas: celulosa, polietileno y aluminio. Tras un primer tratamiento para la recuperación de la celulosa, la fracción de polietileno y aluminio se sigue procesando para generar una nueva segunda materia prima. **Este material reciclado tiene un aspecto estético muy particular** (gracias a la presencia de aluminio junto con el componente plástico) que lo distingue de cualquier otro del mercado.

## Specification

|                   |             |                 |           |                 |       |                  |                         |                         |           |
|-------------------|-------------|-----------------|-----------|-----------------|-------|------------------|-------------------------|-------------------------|-----------|
| <b>Dimensions</b> | 11 x 140 mm | <b>Material</b> | EcoAllene | <b>Finishes</b> | Solid | <b>Ink color</b> | Blue, Black (on demand) | <b>Packaging (pcs.)</b> | 50 / 1000 |
|-------------------|-------------|-----------------|-----------|-----------------|-------|------------------|-------------------------|-------------------------|-----------|

## Branding options

### Clip

Pad printing Side A

4 x 25 mm

### Barrel

Silkscreen printing 300° (Standard) All Side

28 x 45 mm

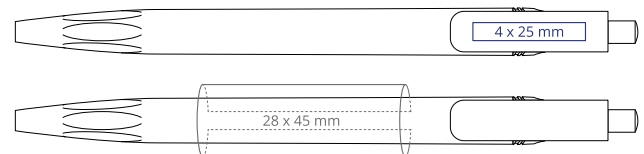





# TANTRA

check it out!



Product code: 404..

# TANTRA

## Colors



|                        |                       |                       |                       |                      |                       |                      |                       |                        |                       |                        |
|------------------------|-----------------------|-----------------------|-----------------------|----------------------|-----------------------|----------------------|-----------------------|------------------------|-----------------------|------------------------|
| <b>01</b><br>PMS White | <b>120</b><br>PMS 012 | <b>05</b><br>PMS 1585 | <b>08</b><br>PMS 7620 | <b>10</b><br>PMS 227 | <b>132</b><br>PMS 368 | <b>18</b><br>PMS 347 | <b>135</b><br>PMS 298 | <b>136</b><br>PMS 2736 | <b>139</b><br>PMS 429 | <b>35</b><br>PMS Black |
|------------------------|-----------------------|-----------------------|-----------------------|----------------------|-----------------------|----------------------|-----------------------|------------------------|-----------------------|------------------------|

- EN**  
Tantra pen with plastic color barrel, head and metal push and clip.
- PL**  
Perfekcja i energia kolorów. Długopis z korpusem w kolorze, czarną dłówką i metalowym chromowanym klipsem.
- IT**  
Penna Tantra con fusto e testina in plastica colorata, pulsante e clip in metallo.
- FR**  
Stylo Tantra avec corps et tête en plastique et poussoir et clip en métal.
- DE**  
Perfektion und Farbenergie. Stift mit farbigem Schaft, schwarzem Kopf und verchromtem Metallclip.
- ES**  
Bolígrafo tantra con cuerpo y cabezal de plástico de color y clip y pulsador metálicos.

## Specification

|                   |             |                 |     |                 |              |                  |                         |                         |           |
|-------------------|-------------|-----------------|-----|-----------------|--------------|------------------|-------------------------|-------------------------|-----------|
| <b>Dimensions</b> | 11 x 145 mm | <b>Material</b> | ABS | <b>Finishes</b> | Solid, Shiny | <b>Ink color</b> | Blue, Black (on demand) | <b>Packaging (pcs.)</b> | 50 / 1000 |
|-------------------|-------------|-----------------|-----|-----------------|--------------|------------------|-------------------------|-------------------------|-----------|

## Branding options

### Clip

Laser engraving Side A

4 x 30 mm



### Barrel

Pad printing Side B,D

Silkscreen printing 300° (Standard) All Side

5 x 45 mm



29 x 55 mm

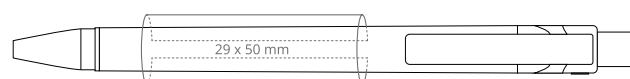



# OTTO White

*check it out!*



Product code: 500..

# OTTO White

EU Production

## Colors

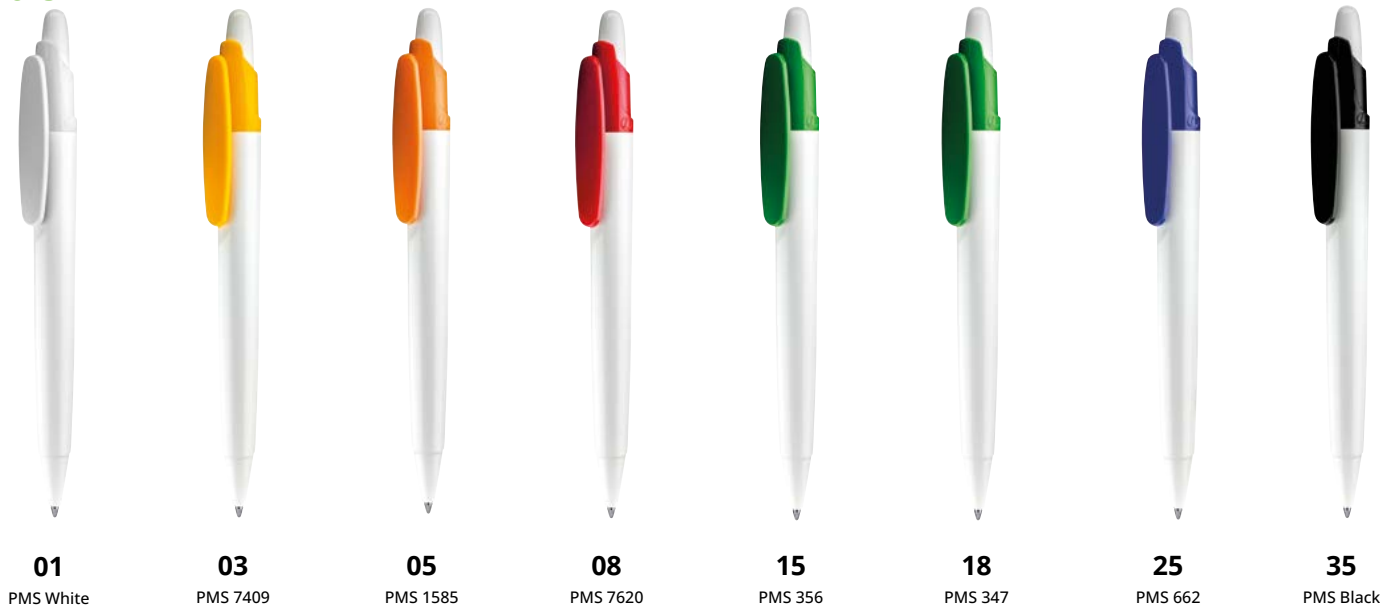

|                        |                       |                       |                       |                      |                      |                      |                        |
|------------------------|-----------------------|-----------------------|-----------------------|----------------------|----------------------|----------------------|------------------------|
| <b>01</b><br>PMS White | <b>03</b><br>PMS 7409 | <b>05</b><br>PMS 1585 | <b>08</b><br>PMS 7620 | <b>15</b><br>PMS 356 | <b>18</b><br>PMS 347 | <b>25</b><br>PMS 662 | <b>35</b><br>PMS Black |
|------------------------|-----------------------|-----------------------|-----------------------|----------------------|----------------------|----------------------|------------------------|

|  |   |   |  |  |   |
|--|---|---|--|--|---|
| <p><b>EN</b></p> <p><b>Otto White</b> has a big clips - perfect for digital printing. Amazing combination of possibility of the printing. Italian design. <b>White barrel and colored accessories.</b></p> | <p><b>PL</b></p> <p><b>Otto White</b> z dużym klipsem, idealnym pod nadruki cyfrowe. Niezliczona kombinacja możliwości nadruku. O włoskich korzeniach. Wersja o białym korpusie i kolorowych dodatkach.</p> | <p><b>IT</b></p> <p><b>Otto White</b> ha una grande clip perfetta per la stampa digitale. Incredibile combinazione di possibilità di stampa. <b>Design italiano. Fusto bianco e accessori colorati.</b></p> | <p><b>FR</b></p> <p><b>Otto White</b> a un grand clip-parfaits pour l'impression numérique. Combinaison étonnante de possibilités d'impression. <b>Design italien. Corps baril blanc et accessoires colorés.</b></p> | <p><b>DE</b></p> <p><b>Otto White</b> mit einem großen Clip, ideal für den Digitaldruck. Unzählige Kombinationen von Druckmöglichkeiten. Mit italienischen Wurzeln. <b>Version mit weißem Schaft und farbigem Zubehör.</b></p> | <p><b>ES</b></p> <p><b>Otto White</b> tiene un gran clip - perfecto para la impresión digital. Increíble combinación de posibilidad de la impresión. <b>Design italiano. Barril blanco y accesorios de color.</b></p> |
|--|---|---|--|--|---|

## Specification

|                   |             |                 |     |                 |              |                  |                         |                         |           |
|-------------------|-------------|-----------------|-----|-----------------|--------------|------------------|-------------------------|-------------------------|-----------|
| <b>Dimensions</b> | 13 x 148 mm | <b>Material</b> | ABS | <b>Finishes</b> | Solid, Shiny | <b>Ink color</b> | Blue, Black (on demand) | <b>Packaging (pcs.)</b> | 50 / 1000 |
|-------------------|-------------|-----------------|-----|-----------------|--------------|------------------|-------------------------|-------------------------|-----------|

## Branding options

### Clip

Digital overprint Side A  
Pad printing Side A

6 x 35 mm  
6 x 35 mm

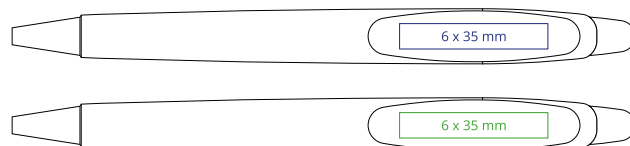

### Barrel

Digital overprint Side B,D  
Silkscreen printing 300° (Standard) Side A  
Silkscreen printing 300° XL (On demand) Side A

5 x 60 mm  
32 x 45 mm  
32 x 60 mm

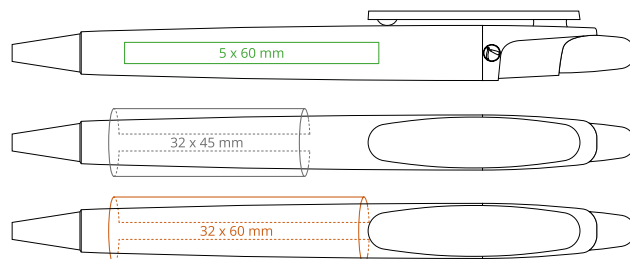



Lecce Pen

# TWISTY

*#let's twist*

*check it out!*



*table of contents*

Product code: 176..

# TWISTY

EU Production

## Colors

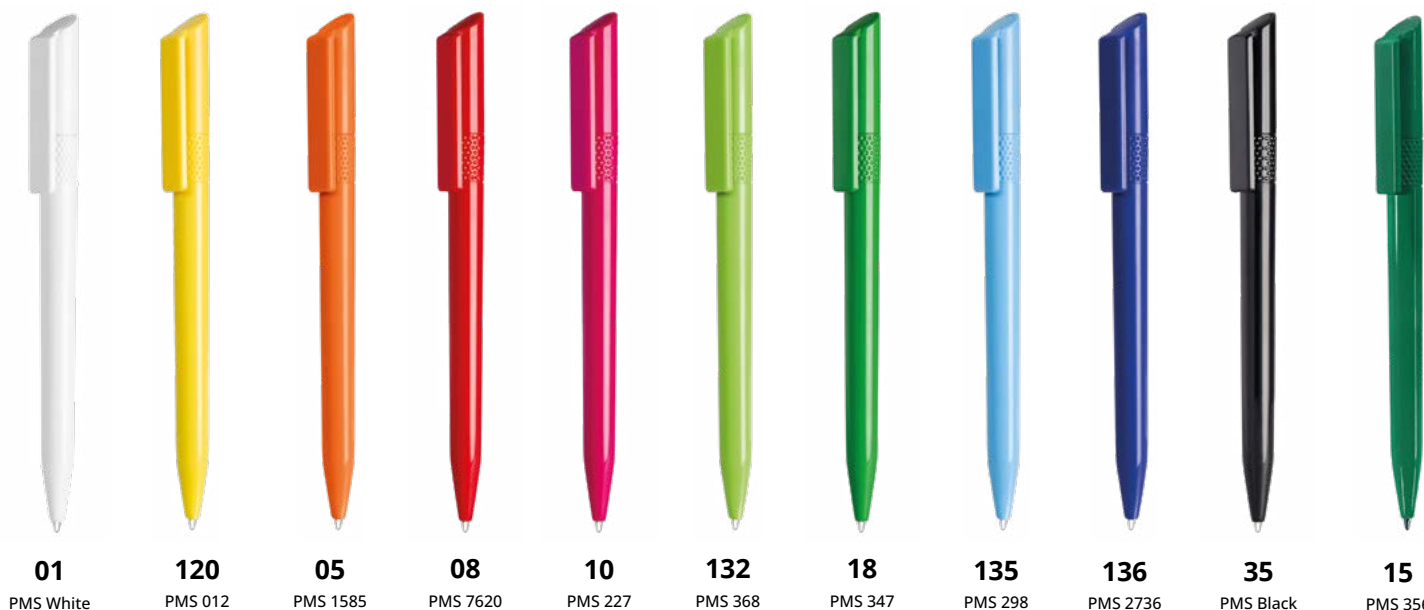

|                        |                       |                       |                       |                      |                       |                      |                       |                        |                        |                      |
|------------------------|-----------------------|-----------------------|-----------------------|----------------------|-----------------------|----------------------|-----------------------|------------------------|------------------------|----------------------|
| <b>01</b><br>PMS White | <b>120</b><br>PMS 012 | <b>05</b><br>PMS 1585 | <b>08</b><br>PMS 7620 | <b>10</b><br>PMS 227 | <b>132</b><br>PMS 368 | <b>18</b><br>PMS 347 | <b>135</b><br>PMS 298 | <b>136</b><br>PMS 2736 | <b>35</b><br>PMS Black | <b>15</b><br>PMS 356 |
|------------------------|-----------------------|-----------------------|-----------------------|----------------------|-----------------------|----------------------|-----------------------|------------------------|------------------------|----------------------|

Sell - out!

|  |   |  |   |   |  |
|--|---|--|---|---|--|
| <p><b>EN</b></p> <p>Twisty is a plastic pen from promotional collection. <b>Color depth in every detail.</b></p> | <p><b>PL</b></p> <p>Twisty długopis plastikowy z kolekcji promocyjnej. <b>Głębokość koloru w każdym detalu.</b></p> | <p><b>IT</b></p> <p>Twisty è una penna in plastica della collezione promozionale. <b>Profondità di colore in ogni dettaglio.</b></p> | <p><b>FR</b></p> <p>Twisty est un stylo en plastique de la collection promotionnelle. <b>La profondeur des couleurs se retrouve dans chaque détail.</b></p> | <p><b>DE</b></p> <p><b>Drehbarer</b> Kunststoffkugelschreiber aus der Werbekollektion. <b>Farbintensität in jedem Detail.</b></p> | <p><b>ES</b></p> <p>Twisty es un bolígrafo de plástico de la colección promocional. <b>Profundidad de color en cada detalle.</b></p> |
|--|---|--|---|---|--|

## Specification

|                   |               |                 |     |                 |              |                  |                         |                         |           |
|-------------------|---------------|-----------------|-----|-----------------|--------------|------------------|-------------------------|-------------------------|-----------|
| <b>Dimensions</b> | 10.5 x 148 mm | <b>Material</b> | ABS | <b>Finishes</b> | Solid, Shiny | <b>Ink color</b> | Blue, Black (on demand) | <b>Packaging (pcs.)</b> | 50 / 1000 |
|-------------------|---------------|-----------------|-----|-----------------|--------------|------------------|-------------------------|-------------------------|-----------|

## Branding options

### Clip

Pad printing Side A

5 x 35 mm



### Barrel

Digital overprint Side B,D

5 x 60 mm



Silkscreen printing 300° (Standard) All Side

27 x 55 mm

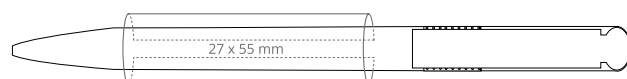

Product code: 206..

# TRIS Chrome

EU Production

check it out!



## Colors

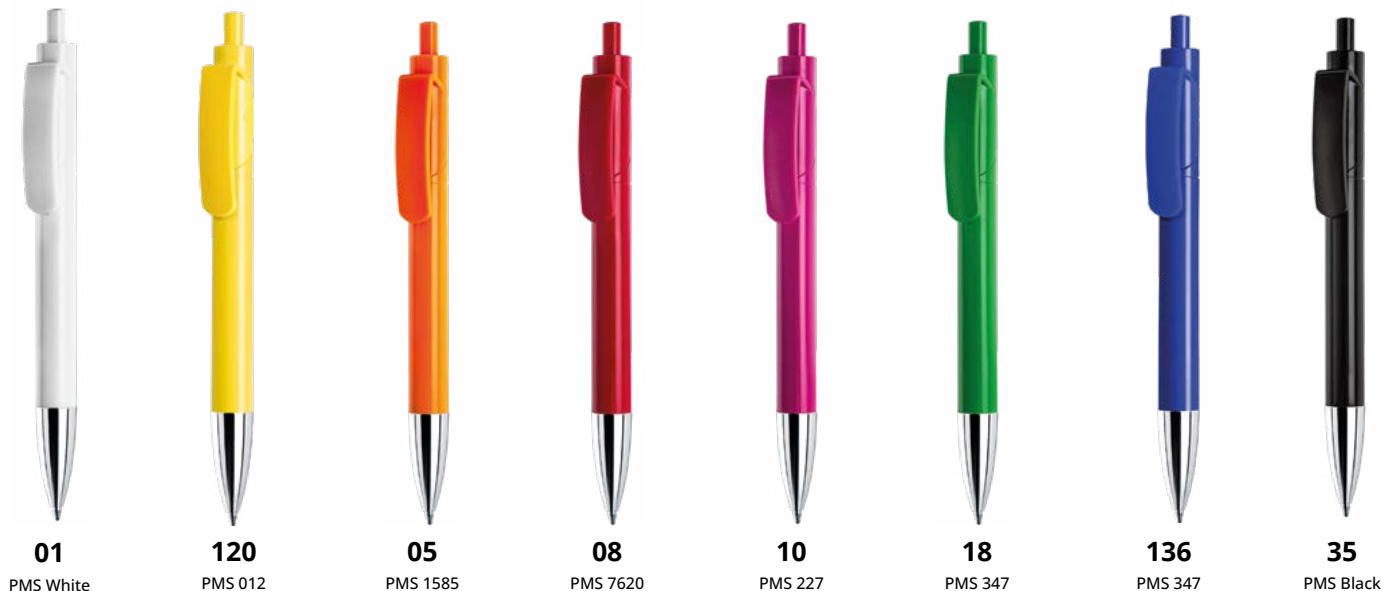

EN

**Tris Chrome** is a classic elegance melted with modern design. **Chromed version.** Variety of finishes, wide range of colors and big area for personalization. Richness of expression.

PL

**Tris Chrome** - klasyczna elegancja połączona z nowoczesnym designem, a także szeroka gama kolorów, duże pole znakowania i różnorodność wykończeń. **Chromowany.** Bogactwo ekspresji i elegancja.

IT

**Tris Chrome** è un'eleganza classica fusa con un design moderno. **Versione cromata.** Varietà di finiture, ampia gamma di colori e grande spazio per la personalizzazione. Ricchezza di espressione.

FR

**Tris Chrome**, c'est l'élégance classique alliée à un design moderne. **Version chromée.** Variété de finitions, large gamme de couleurs et grand espace de personnalisation. Richesse d'expression.

DE

**Tris Chrome** - klassische Eleganz kombiniert mit modernem Design, sowie eine breite Farbpalette, eine große Druckfläche. **Chrom.** Eine Fülle von Ausdruck und Eleganz.

ES

**Tris Chrome** es una elegancia clásica fundada con un diseño moderno. **Versión cromada.** Variedad de acabados, amplia gama de colores y gran espacio para la personalización. Riqueza de expresión.

## Specification

|                   |             |                 |     |                 |               |                  |                                  |                         |           |
|-------------------|-------------|-----------------|-----|-----------------|---------------|------------------|----------------------------------|-------------------------|-----------|
| <b>Dimensions</b> | 11 x 138 mm | <b>Material</b> | ABS | <b>Finishes</b> | Chrome, Solid | <b>Ink color</b> | Blue, Black ( <i>on demand</i> ) | <b>Packaging (pcs.)</b> | 50 / 1000 |
|-------------------|-------------|-----------------|-----|-----------------|---------------|------------------|----------------------------------|-------------------------|-----------|

## Branding options

### Clip

Digital overprint Side A  
Pad printing Side A

6 x 30 mm  
6 x 30 mm



### Barrel

Digital overprint Side B,D  
Silkscreen printing 300° (Standard) All Side

5 x 55 mm  
30 x 37 mm



Product code: 202..

# TRIS Solid

EU Production

check it out!



## Colors

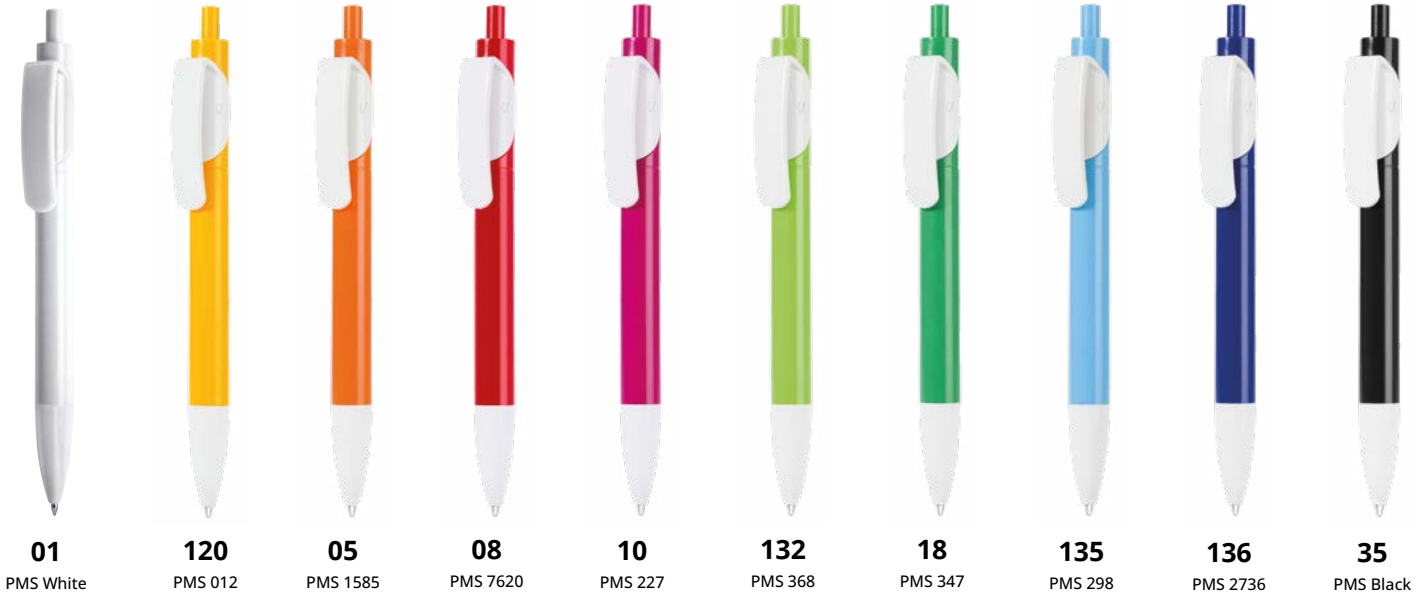

- EN**

**Tris Solid** is a classic elegance melted with modern design. Variety of finishes, wide range of colors and big area for personalization. Richness of expression.
- PL**

**Tris Solid** - klasyczna elegancja połączona z nowoczesnym designem, a także szeroka gama kolorów, duże pole znakowania i różnorodność wykończeń. **Bogactwo ekspresji.**
- IT**

**Tris Solid** è un'eleganza classica fusa con un design moderno. Varietà di finiture, ampia gamma di colori e grande spazio per la personalizzazione. **Ricchezza di espressione.**
- FR**

**Tris Solid** est un mélange d'élegance classique et de design moderne. Variété de finitions, large gamme de couleurs et grande surface de personnalisation. **Richesse d'expression.**
- DE**

**Tris Solid** - klassische Eleganz kombiniert mit modernem Design, einer breiten Farbpalette, einer großen Beschriftungsfläche. **Eine Menge von Ausdrucksmöglichkeiten.**
- ES**

**Tris Solid** es una elegancia clásica fundida con un diseño moderno. Variedad de acabados, amplia gama de colores y gran espacio para la personalización. **Riqueza de expresión.**

## Specification

|                   |             |                 |     |                 |              |                  |                         |                         |           |
|-------------------|-------------|-----------------|-----|-----------------|--------------|------------------|-------------------------|-------------------------|-----------|
| <b>Dimensions</b> | 11 x 138 mm | <b>Material</b> | ABS | <b>Finishes</b> | Solid, Shiny | <b>Ink color</b> | Blue, Black (on demand) | <b>Packaging (pcs.)</b> | 50 / 1000 |
|-------------------|-------------|-----------------|-----|-----------------|--------------|------------------|-------------------------|-------------------------|-----------|

## Branding options

### Clip

Digital overprint Side A

6 x 30 mm

Pad printing Side A

6 x 30 mm

### Barrel

Digital overprint Side B,D

5 x 55 mm

Silkscreen printing 300° (Standard) All Side

30 x 37 mm

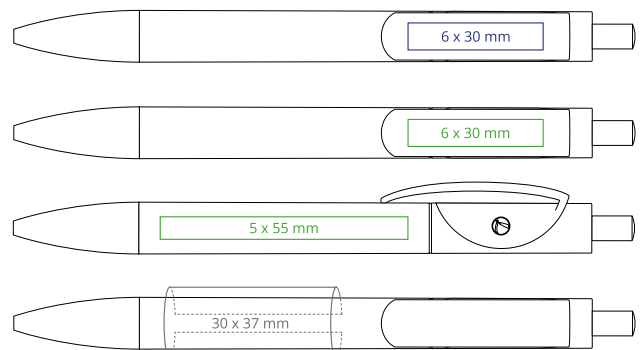



Product code: 410ST..

# GOLFF Safetouch

## #antibacterial



Ask For *check it out!*



EU Production

### Colors



**01**  
PMS White



**102**  
PMS 712



**103**  
PMS 705



**105**  
PMS 628



**106**  
PMS 290



**139**  
PMS 429

**EN**

**Golff SafeTouch** - very comfortable to use. The original head imitates the golf ball and it creates a light unique style. **Antibacterial version.**

**PL**

**Golff SafeTouch** lekki, bardzo komfortowy w użytkowaniu. Flagowy model z kolekcji antybakteryjnej. **W trosce o zdrowie i bezpieczeństwo.**

**IT**

**Golff SafeTouch** - molto comodo da usare. L'originale testa imita la pallina da golf e crea uno stile leggero e unico. **Versione antibatterica.**

**FR**

**Golff SafeTouch** - très confortable à utiliser. La tête originale imite la balle de golf et crée un style léger et unique. **Version antibactérienne.**

**DE**

**Golff SafeTouch** leicht, sehr angenehm zu halten. Das Vorgeigemodell der antibakteriellen Kollektion. **Der Gesundheit und Sicherheit zuliebe.**

**ES**

**Golff SafeTouch** - muy cómodo de usar. El original cabezal imita la pelota de golf y crea un ligero estilo único. **Versión antibacteriana.**

## Specification

|                   |             |                 |                                 |                 |              |                  |                                  |                         |           |
|-------------------|-------------|-----------------|---------------------------------|-----------------|--------------|------------------|----------------------------------|-------------------------|-----------|
| <b>Dimensions</b> | 10 x 144 mm | <b>Material</b> | ABS with Antibacterial additive | <b>Finishes</b> | Solid, Shiny | <b>Ink color</b> | Blue, Black ( <i>on demand</i> ) | <b>Packaging (pcs.)</b> | 50 / 1000 |
|-------------------|-------------|-----------------|---------------------------------|-----------------|--------------|------------------|----------------------------------|-------------------------|-----------|

## Branding options

### Clip

Digital overprint Side A  
Pad printing Side A

5 x 19 mm  
5 x 23 mm

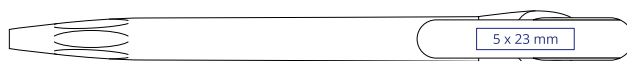

### Barrel

Digital overprint Side B,D  
Silkscreen printing 300° (Standard) All Side

4 x 60 mm  
5 x 45 mm  
28 x 45 mm

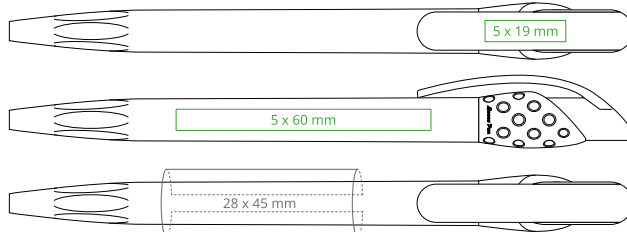

Product code: 414

# GOLFF Solid

EU Production

Ask For

check it out!



## Colors



01

PMS White

120

PMS 012

05

PMS 1585

08

PMS 7620

10

PMS 227

132

PMS 368

18

PMS 347

135

PMS 298

136

PMS 2736

35

PMS Black

EN

**Golff ballpen** comfortable to use. The original head with a texture imitating a golf ball creates a light, unique style. **Color version, solid finishing.**

PL

**Golff** bardzo komfortowy w użytkowaniu. Oryginalna główka z fakturą imitującą piłeczkę golfową tworzy lekki, niepowtarzalny styl. **Wersja w kolorze, lity wyblyszczony.**

IT

Penna a sfera **Golff** comoda da usare. L'originale testina con una texture che imita una pallina da golf crea uno stile leggero e unico. **Versione a colori, finitura solida.**

FR

Stylo-bille **Golff** confortable à utiliser. La tête originale avec une texture imitant une balle de golf crée un style léger et unique. **Version couleur, finition solide.**

DE

Kugelschreiber **Golff**. Der originelle, strukturierte Kopf, der einen Golfball imitiert, schafft einen leichten, einzigartigen Stil. **Farbe Version, solide glänzend.**

ES

Bolígrafo **Golff** cómodo de usar. El original cabezal con una textura que imita una pelota de golf crea un estilo ligero y único. **Versión en color, acabado sólido.**

## Specification

|                   |             |                 |     |                 |              |                  |                         |                         |           |
|-------------------|-------------|-----------------|-----|-----------------|--------------|------------------|-------------------------|-------------------------|-----------|
| <b>Dimensions</b> | 10 x 144 mm | <b>Material</b> | ABS | <b>Finishes</b> | Solid, Shiny | <b>Ink color</b> | Blue, Black (on demand) | <b>Packaging (pcs.)</b> | 50 / 1000 |
|-------------------|-------------|-----------------|-----|-----------------|--------------|------------------|-------------------------|-------------------------|-----------|

## Branding options

### Clip

Digital overprint Side A  
Pad printing Side A

5 x 19 mm  
5 x 23 mm

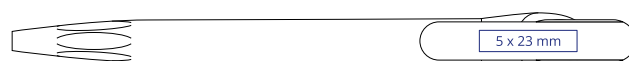

### Barrel

Digital overprint Side B,D  
Silkscreen printing 300° (Standard) All Side

4 x 60 mm  
28 x 45 mm

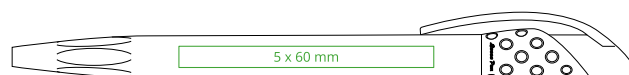

Product code: 392EWST..

# KIKI Eco SafeTouch



Ask For

check it out!



EU Production

## Colors



01

PMS White



05

PMS 1585



08

PMS 7620



15

PMS 356



22

PMS 2925



24

PMS 301



35

PMS Black

EN

**Antibacterial eco-friendly** pens made of recycled beverage cartons. Result of combining traditional plastics with an antibacterial addition **BIOMASTER** inhibiting the growth and spread of microorganisms. The product prototypes have positively undergone microbiological tests accordance with the standard - **ISO 22196:2011**. With the new technology, end products will have exceptionally strong biostatic properties that will reduce 99% of bacteria and positively impact safety, health, hygiene and, consequently, the quality of life.

PL

**EcoLine** jest kolekcją długopisów wykonaną ze specjalnego materiału pochodzącego z recyklingu kartoników po napojach. Używany w naszych produktach dodatek antybakteryjny **BIOMASTER** pochodzenia nieorganicznego o działaniu antybakteryjnym i antygrzybicznym stworzono w Unii Europejskiej zgodnie z unijnymi normami i wymogami. Efekt biostatyczny został potwierdzony badaniami laboratoryjnymi przeprowadzonymi zgodnie z normą - **ISO 22196:2011**.

IT

Penne **ecologiche antibatteriche** realizzate con cartoni per bevande riciclati. Risultato della combinazione di plastiche tradizionali con un additivo antibatterico **BIOMASTER** che inibisce la crescita e la diffusione dei microrganismi. I prototipi del prodotto sono stati sottoposti a test microbiologici secondo lo standard **ISO 22196:2011**. Grazie alla nuova tecnologia, i prodotti finali avranno proprietà biostatiche eccezionalmente forti che ridurranno il 99% dei batteri e avranno un impatto positivo sulla sicurezza, sulla salute, sull'igiene e, di conseguenza, sulla qualità della vita.

FR

Stylos **écologiques antibactériens** fabriqués à partir de briques à boisson recyclées. Résultat de la combinaison de plastiques traditionnels avec un ajout additif antibactérien **BIOMASTER** inhibant la croissance et la propagation des micro-organismes. Les prototypes du produit ont été soumis à des tests microbiologiques conformes à la norme **ISO 22196 : 2011**. Grâce à cette nouvelle technologie, les produits finis auront des propriétés biostatiques exceptionnellement fortes qui réduiront 99 % des bactéries et auront un impact positif sur la sécurité, la santé, l'hygiène et, par conséquent, la qualité de vie.

DE

**EcoLine** ist eine Kollektion von **Kugelschreibern** aus einem speziellen Material, das aus recycelten Getränkekartons hergestellt wird. Der anorganische antibakterielle und antimykotische Zusatzstoff **BIOMASTER**, der in unseren Produkten verwendet wird, wurde in der Europäischen Union in Übereinstimmung mit den EU-Normen und -Anforderungen entwickelt. Die biostatistische Wirkung wurde durch Labortests bestätigt, die gemäß der Norm **ISO 22196:2011** durchgeführt wurden.

ES

Bolígrafos **ecológicos antibacterianos** fabricados con cartones de bebidas reciclados. Resultado de la combinación de plásticos tradicionales con un additivo antibacteriano **BIOMASTER** que inhibe el crecimiento y la propagación de microorganismos. Los prototipos del producto se han sometido positivamente a pruebas microbiológicas de acuerdo con la norma - **ISO 22196:2011**. Con la nueva tecnología, los productos finales tendrán propiedades bioestáticas excepcionalmente fuertes que reducirán el 99% de las bacterias y tendrán un impacto positivo en la seguridad, la salud, la higiene y, en consecuencia, la calidad de vida.

## Specification

|                   |             |                 |                                       |                 |       |                  |                         |                         |           |
|-------------------|-------------|-----------------|---------------------------------------|-----------------|-------|------------------|-------------------------|-------------------------|-----------|
| <b>Dimensions</b> | 11 x 144 mm | <b>Material</b> | EcoAllene with antibacterial additive | <b>Finishes</b> | Solid | <b>Ink color</b> | Blue, Black (on demand) | <b>Packaging (pcs.)</b> | 50 / 1000 |
|-------------------|-------------|-----------------|---------------------------------------|-----------------|-------|------------------|-------------------------|-------------------------|-----------|

## Branding options

Clip

Pad printing Side A

5 x 30 mm

Barrel

Silkscreen printing 300° (Standard) All Side

28 x 45 mm

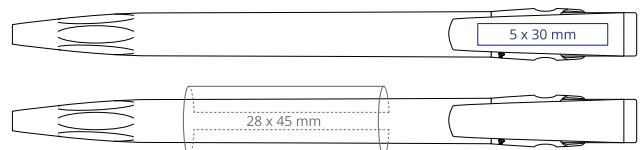

Product code: 392EB..

# KIKI EcoLine EB



#eco

Ask For

check it out!



EU Production

## Colors



**01**  
PMS White



**05**  
PMS 1585



**08**  
PMS 7620



**10**  
PMS 227



**15**  
PMS 356



**19**  
PMS 389



**22**  
PMS 2925



**24**  
PMS 301



**35**  
PMS Black

**EN**  
Kiki EcoLine was made in accordance with the needs of the market and caring for natural environment. A new and innovative product. Black version.

\* In the interest of marking quality we decided to change packing of EcoLine products.

**PL**  
Kiki EcoLine smukły i ekologiczny. Niebojętny na problemy związane z ochroną środowiska. Nowoczesny, unikalny, niepowtarzalny.

\* W trosce o jakość i trwałość znakowania na długopisach zmieniliśmy pakowanie produktu.

**IT**  
Kiki EcoLine è stato realizzato in base alle esigenze del mercato e alla cura dell'ambiente naturale. Un prodotto nuovo e innovativo. Versione nera.

\* Nell'interesse della qualità della stampa abbiamo deciso di cambiare l'imballaggio dei prodotti EcoLine.

**FR**  
Kiki EcoLine a été conçu en fonction des besoins du marché et de la protection de l'environnement naturel. Un produit nouveau et innovant. Version noire.

\* Dans l'intérêt de la qualité, nous avons décidé de changer l'emballage des produits EcoLine.

**DE**  
Kiki EcoLine schlank und ökologisch. Nicht gleichgültig gegenüber Umweltbelangen. Modern, einzigartig, unnachahmlich.

\* Wir haben die Verpackung des Produkts geändert, um die Qualität und Haltbarkeit der Markierung auf den Stiften zu gewährleisten.

**ES**  
Kiki EcoLine se ha fabricado teniendo en cuenta las necesidades del mercado y el cuidado del entorno natural. Un producto nuevo e innovador. Versión en negro.

\* En el interés de la calidad de marcaje de los productos EcoLine.

## Specification

|                   |             |                 |           |                 |       |                  |                         |                         |           |
|-------------------|-------------|-----------------|-----------|-----------------|-------|------------------|-------------------------|-------------------------|-----------|
| <b>Dimensions</b> | 11 x 144 mm | <b>Material</b> | EcoAllene | <b>Finishes</b> | Solid | <b>Ink color</b> | Blue, Black (on demand) | <b>Packaging (pcs.)</b> | 50 / 1000 |
|-------------------|-------------|-----------------|-----------|-----------------|-------|------------------|-------------------------|-------------------------|-----------|

## Branding options

### Clip

Pad printing Side A

5 x 30 mm

### Barrel

Silkscreen printing 300° (Standard) All Side

28 x 45 mm

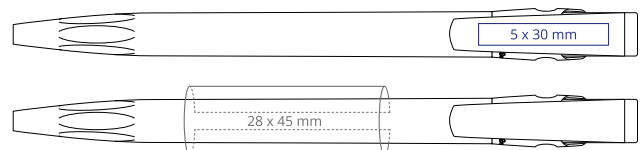

Product code: 392EW.. | 392EW..S

# KIKI EcoLine EW



#eco

Ask for

check it out!



EU Production

## Colors



01

PMS White

05

PMS 1585

08

PMS 7620

10

PMS 227

15

PMS 356

19

PMS 389

22

PMS 2925

24

PMS 301

35

PMS Black

43

PMS 470

30

PMS 423

EN

**EcoLine** is a line of writing instruments made in a special material coming from the recycling of beverage cartons. Beverage cartons are in fact composed of several layers: cellulose, polyethylene and aluminum. After a first processing for the recovery of cellulose, the fraction of polyethylene and aluminum is further processed to generate a new second raw material. This recycled material has a very particular aesthetic aspect (thanks to the presence of aluminum together with the plastic component) which distinguishes it from any other on the market.

PL

**EcoLine** jest kolekcją długopisów wykonaną ze specjalnego materiału pochodzącego z recyklingu kartoników po napojach. Kartoniki te wykonane są z kilku warstw: celulozy, polietylenu i aluminium. Po pierwszym etapie odzyskiwania celulozy frakcja polietylenu i aluminium jest dalej przetwarzana w celu wytworzenia nowego surowca. Uzyskany w ten sposób materiał posiada bardzo szczególną wartość estetyczną (dzięki obecności aluminium połączonego z plastikiem), która wyróżnia go spośród innych obecnych na rynku materiałów.

IT

**EcoLine** è una linea di strumenti di scrittura realizzati in uno speciale materiale proveniente dal riciclo dei cartoni per bevande. I cartoni per bevande sono infatti composti da diversi strati: cellulosa, polietilene e alluminio. Dopo una prima lavorazione per il recupero della cellulosa, la frazione di polietilene e alluminio viene ulteriormente lavorata per generare una nuova materia prima seconda. Questo materiale riciclato ha un aspetto estetico molto particolare (grazie alla presenza dell'alluminio insieme alla componente plastica) che lo distingue da qualsiasi altro sul mercato.

FR

**EcoLine** est une ligne d'instruments d'écriture fabriqués dans un matériau spécial issu du recyclage des briques à boisson. Les briques des boissons sont en effet composées de plusieurs couches : cellulose, polyéthylène et aluminium. Après un premier traitement pour la récupération de la cellulose, la fraction de polyéthylène et d'aluminium est transformée pour générer une nouvelle matière première. Ce matériau recyclé a un aspect esthétique très particulier (grâce à la présence de l'aluminium avec la composante plastique) qui le distingue de tous les autres sur le marché.

DE

**EcoLine** ist eine Kollektion von Kugelschreibern aus einem speziellen Material, das aus recycelten Getränkekartons hergestellt wird. Diese Kartons bestehen aus mehreren Schichten: Zellulose, Polyethylen und Aluminium. Nach der ersten Stufe der Zellulosewiedergewinnung wird die Polyethylen- und Aluminiumfraktion weiterverarbeitet, um ein neues Rohmaterial herzustellen. Das daraus resultierende Material hat einen ganz besonderen ästhetischen Wert (dank des Aluminiums in Kombination mit Kunststoff), der es von anderen Materialien auf dem Markt unterscheidet.

ES

**EcoLine** es una línea de instrumentos de escritura fabricados con un material especial procedente del reciclado de cartones de bebidas. De hecho, los cartones de bebidas se componen de varias capas: celulosa, polietileno y aluminio. Tras un primer tratamiento para la recuperación de la celulosa, la fracción de polietileno y aluminio se sigue procesando para generar una nueva segunda materia prima. Este material reciclado tiene un aspecto estético muy particular (gracias a la presencia de aluminio junto con el componente plástico) que lo distingue de cualquier otro del mercado.

## Specification

|            |             |          |           |          |       |           |                         |                  |           |
|------------|-------------|----------|-----------|----------|-------|-----------|-------------------------|------------------|-----------|
| Dimensions | 11 x 144 mm | Material | EcoAllene | Finishes | Solid | Ink color | Blue, Black (on demand) | Packaging (pcs.) | 50 / 1000 |
|------------|-------------|----------|-----------|----------|-------|-----------|-------------------------|------------------|-----------|

## Branding options

Clip

Pad printing Side A

5 x 30 mm



Barrel

Silkscreen printing 300° (Standard) All Side

28 x 45 mm



Product code: 397..

# KIKI Solid

EU Production

Ask for

check it out!



## Colors



**01**  
PMS White



**120**  
PMS 012



**05**  
PMS 1585



**08**  
PMS 7620



**10**  
PMS 227



**132**  
PMS 368



**18**  
PMS 347



**135**  
PMS 298



**136**  
PMS 2736



**35**  
PMS Black

EN

Kiki with a slim body, in full color version. Beautifully exposes the print. Eye-catching proposition.

PL

Kiki o smukłej obudowie, w wersji cały w kolorze. Pięknie eksponuje nadruk. Przyciąga wzrok.

IT

Kiki con un corpo sottile, in versione full color. Espone splendidamente la stampa. Proposta accattivante.

FR

Kiki avec un corps mince, en version couleur. L'imprimé est magnifiquement mis en valeur. Proposition captivante.

DE

Kiki mit einem dünnen Schaft, einer Version ganz in Farbe. Bringt den Druck wunderschön zur Geltung. Ein Blickfang.

ES

Kiki con un cuerpo esbelto, en versión a todo color. Expone maravillosamente el elgado. Propuesta llamativa.

## Specification

|            |             |          |     |          |              |           |                         |                  |           |
|------------|-------------|----------|-----|----------|--------------|-----------|-------------------------|------------------|-----------|
| Dimensions | 10 x 145 mm | Material | ABS | Finishes | Solid, Shiny | Ink color | Blue, Black (on demand) | Packaging (pcs.) | 50 / 1000 |
|------------|-------------|----------|-----|----------|--------------|-----------|-------------------------|------------------|-----------|

## Branding options

### Clip

Digital overprint Side A

Pad printing Side A

5 x 30 mm

5 x 30 mm



### Barrel

Digital overprint Side B,D

Silkscreen printing 300° (Standard)

4 x 60 mm

28 x 45 mm

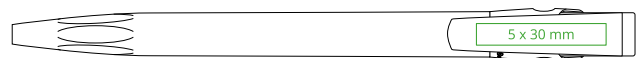

# PowerBank Forte | Forte ST

#fullofpower | #antibacterial



Lecce Pen

table of contents

Product code: PBF.. | PBST..

# PowerBank Forte | Forte ST

EU Production

check it out!



## Colors



## Colors antibacterial



## Example



### EN

**Forte PowerBank** - the most colorful powerbank and the perfect pen mate! **Combine your colors and create the perfect** PowerBank Forte!

**PowerBank Forte** with an antibacterial additive SafeTouch.

### PL

Najbardziej kolorowy wśród **PowerBanków** z możliwością idealnego dopasowania w zestawie z długopisem Forte. **Do** bierz swoje kolory z bogatej palety dostępnych możliwości i stwórz perfekcyjny **PowerBank** pod Twoją markę!

**PowerBank Forte** z dodatkiem antybakteryjnym SafeTouch

### IT

**PowerBank Forte** - il powerbank più colorato e il compagno di penna perfetto! **Com** binate i vostri colori e create il **PowerBank Forte** perfetto!

**PowerBank Forte** con additivo antibatterico SafeTouch.

### FR

**Forte PowerBank** - le powerbank le plus coloré et le compagnon parfait de votre stylo! **Com** binez vos couleurs et créez le **PowerBank Forte** parfait!

**PowerBank Forte** avec un additif antibactérien SafeTouch.

### DE

Die farbenfrohe unter den **PowerBanks** mit der Möglichkeit, sie perfekt mit dem Stiftset Forte zu kombinieren. **Wählen Sie Ihre Farben** aus der breiten Palette an Möglichkeiten und kreieren Sie die perfekte **PowerBank** für Ihre Marke!

**PowerBank Forte** mit antibakteriellem SafeTouch-Zusatz

### ES

**Forte PowerBank** - ¡el powerbank más colorido y el compañero de bolígrafo perfecto! **Com** bina tus colores y crea el **PowerBank Forte** perfecto.

**PowerBank Forte** con aditivo antibacteriano SafeTouch.

## Specification

|                   |            |                 |     |                 |              |                                 |   |                         |          |
|-------------------|------------|-----------------|-----|-----------------|--------------|---------------------------------|---|-------------------------|----------|
| <b>Dimensions</b> | 91 x 23 mm | <b>Material</b> | ABS | <b>Finishes</b> | Solid, Shiny | <b>parameters and additives</b> | Li-polimer, 5V 1,5A<br>Micro USB cable  <br>Antybacterial | <b>Packaging (pcs.)</b> | 50 / 100 |
|-------------------|------------|-----------------|-----|-----------------|--------------|---------------------------------|---|-------------------------|----------|

## Branding options

### Clip

Pad printing

10 x 38 mm

### Barrel

Silkscreen printing 300°

60 x 70 mm

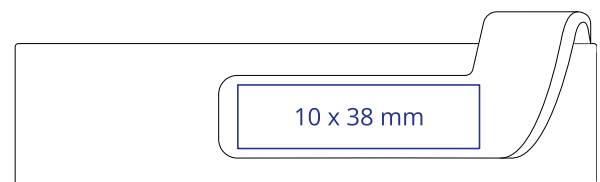
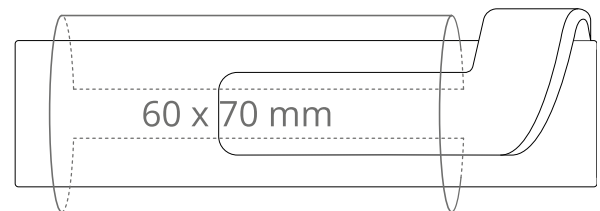



Product code: 415MB..

# GOLFF Green

## #eco

EU Production

### Colors

Special  
production 5k.

check it out!



01

PMS White



03

PMS 7409



08

PMS 7620



15

PMS 347



24

PMS 662



35

PMS Black

EN

**Golff Green** unique in its form and origin - created from **BIOPLAST**, a **biodegradable material** obtained from corn starch. Natural, but original.

PL

**Golff Green** wyjątkowy w swej formie i pochodzeniu - stworzony z **BIOPLASTU**, materiału **biodegradowalnego** uzyskanego ze skrobi kukurydzianej. Naturalny, lecz niebanalny.

IT

**Golff Green** è unico per forma e origine: è stato creato con **BIOPLAST**, un **materiale biodegradabile** ottenuto dall'amido di mais. Naturale, ma originale.

FR

**Golff Green**, unique par sa forme et son origine, est créé à partir de **BIOPLAST**, un **matériau biodégradable** obtenu à partir de l'amidon de maïs. Naturel, mais original.

DE

**Golff Green** ist einzigartig in seiner Form - hergestellt aus **BIOPLAST**, einem **biologisch abbaubaren Material**, das aus Maisstärke gewonnen wird. Natürlich und doch bemerkenswert.

ES

**Golff Green** único en su forma y origen: creado a partir de **BIOPLAST**, un **material biodegradable** obtenido del almidón de maíz. Natural, pero original.

## Specification

|                   |             |                 |           |                 |              |                  |                                  |                         |           |
|-------------------|-------------|-----------------|-----------|-----------------|--------------|------------------|----------------------------------|-------------------------|-----------|
| <b>Dimensions</b> | 10 x 144 mm | <b>Material</b> | Bioplast® | <b>Finishes</b> | Solid, Frost | <b>Ink color</b> | Blue, Black ( <i>on demand</i> ) | <b>Packaging (pcs.)</b> | 50 / 1000 |
|-------------------|-------------|-----------------|-----------|-----------------|--------------|------------------|----------------------------------|-------------------------|-----------|

## Branding options

### Clip

Digital overprint Side A  
Pad printing Side A

5 x 19 mm  
5 x 23 mm

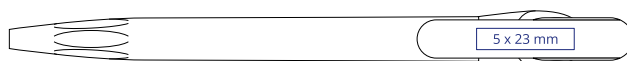

### Barrel

Digital overprint Side B,D  
Silkscreen printing 300° (Standard) All Side

4 x 60 mm  
5 x 45 mm  
28 x 45 mm

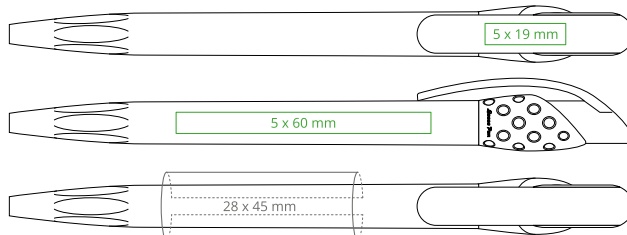

Product code: 191G..

# ZEN Soft

#sosoft

EU Production

## Colors

Special production 5k.

check it out!

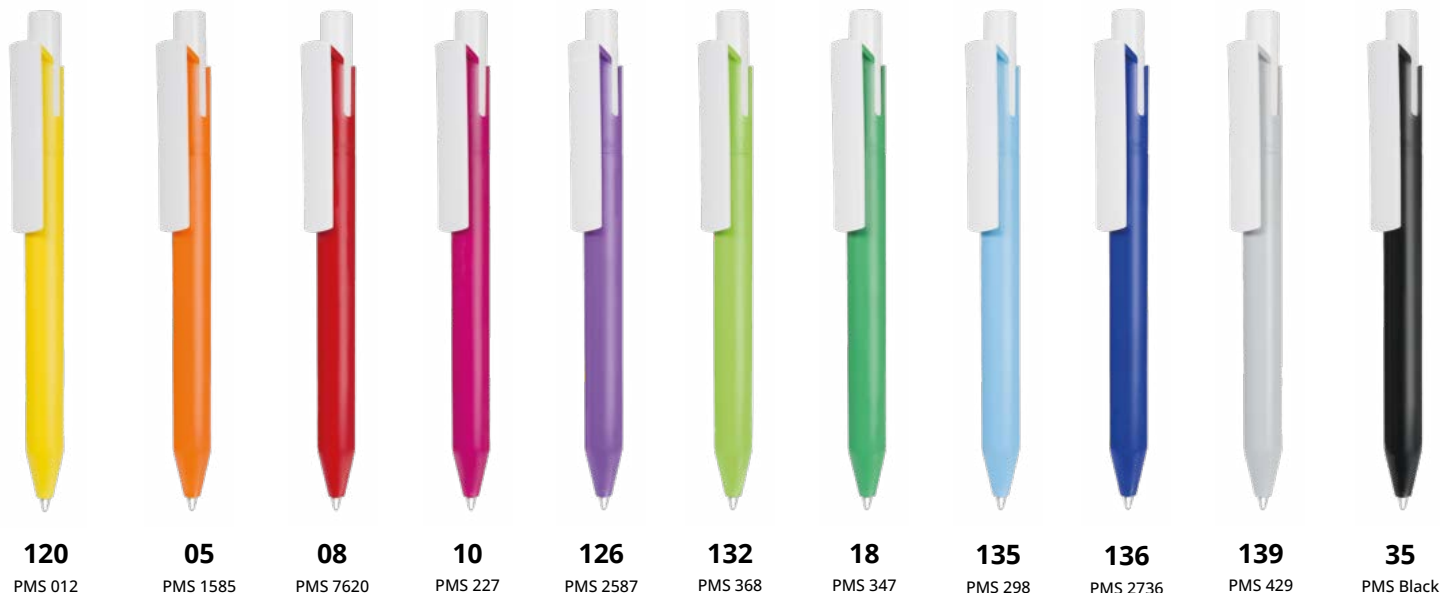

|  |   |   |   |  |  |
|--|---|---|---|--|--|
| <p><b>EN</b></p> <p>Zen Soft has a wide range of colors and a wide possibility to printing. Find the color. Join the game. Express your brand.</p> | <p><b>PL</b></p> <p>Zen Soft to ogrom możliwości kolorystycznych i serwisowych. Wysoka jakość wykonania we włoskim stylu.</p> | <p><b>IT</b></p> <p>Zen Soft ha una vasta gamma di colori e un'ampia possibilità di stampa. Trovate il colore. Partecipa al gioco. Esprimete il vostro marchio.</p> | <p><b>FR</b></p> <p>Zen Soft dispose d'une large gamme de couleurs et d'une large possibilité d'impression. Trouvez la couleur. Participez au jeu. Exprimez votre marque.</p> | <p><b>DE</b></p> <p>Zen Soft bietet eine Fülle von Farb- und Servicemöglichkeiten. Hochwertige Verarbeitung im italienischen Stil.</p> | <p><b>ES</b></p> <p>Zen Soft tiene una amplia gama de colores y una gran posibilidad de impresión. Encuentra el color. Únete al juego. Expresa tu marca.</p> |
|--|---|---|---|--|--|

## Specification

|                   |             |                 |     |                 |           |                  |                         |                         |           |
|-------------------|-------------|-----------------|-----|-----------------|-----------|------------------|-------------------------|-------------------------|-----------|
| <b>Dimensions</b> | 11 x 143 mm | <b>Material</b> | ABS | <b>Finishes</b> | SoftTouch | <b>Ink color</b> | Blue, Black (on demand) | <b>Packaging (pcs.)</b> | 50 / 1000 |
|-------------------|-------------|-----------------|-----|-----------------|-----------|------------------|-------------------------|-------------------------|-----------|

## Branding options

### Clip

Pad printing Side A

7 x 45 mm



### Barrel

Silkscreen printing 300° (Standard) All Side

30 x 40 mm

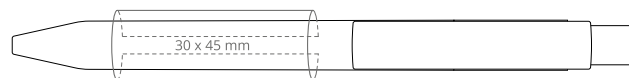

Silkscreen printing 300° XL (On demand) All Side

30 x 60 mm

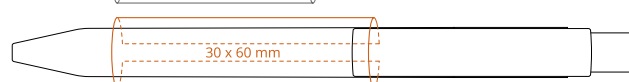

Product code: 151..

# Nove

EU Production

## Special production 5k.

check it out!

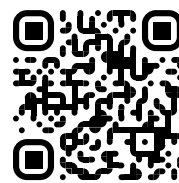

### Colors

**01**

PMS White

**120**

PMS 012

**05**

PMS 1585

**08**

PMS 7620

**10**

PMS 227

**132**

PMS 368

**18**

PMS 347

**135**

PMS 298

**136**

PMS 2736

**35**

PMS Black

**EN**

A pen with a rubber grip. The pen barrel is white, and the accessories are in color.

**PL**

Długopis z gumowym gripem. Korpus długopisu biały, dodatki w kolorze.

**IT**

Penna con grip in gomma. Il corpo della penna è bianco e gli accessori sono colorati

**FR**

Stylo avec grip en caoutchouc. Le corps du stylo est blanc, et les accessoires sont colorés.

**DE**

Kugelschreiber mit gummiertem Griff. Das Gehäuse des Kugelschreibers ist weiß, und das Zubehör ist farbig.

**ES**

Bolígrafo con grip de goma. El cuerpo del bolígrafo es blanco, y los accesorios son de color.

### Specification

|                   |             |                 |     |                 |              |                  |                                  |                         |           |
|-------------------|-------------|-----------------|-----|-----------------|--------------|------------------|----------------------------------|-------------------------|-----------|
| <b>Dimensions</b> | 11 x 141 mm | <b>Material</b> | ABS | <b>Finishes</b> | Solid, Shiny | <b>Ink color</b> | Blue, Black ( <i>on demand</i> ) | <b>Packaging (pcs.)</b> | 30 / 1200 |
|-------------------|-------------|-----------------|-----|-----------------|--------------|------------------|----------------------------------|-------------------------|-----------|

### Branding options

#### Clip

|                   |           |
|-------------------|-----------|
| Digital overprint | 6 x 28 mm |
| Pad printing      | 6 x 28 mm |

#### Barrel

|                                     |            |
|-------------------------------------|------------|
| Digital overprint                   | 5 x 60 mm  |
| Pad printing                        | 5 x 45 mm  |
| Silkscreen printing 300° (Standard) | 30 x 40 mm |

Product code: FNS..

# NOVE Swing

#creativity

EU Production

## Example



Special production 5k.

check it out!



EN

Plastic ballpen with internal rotating tube. Nove Swing will help you to impress customers by its original technique of messages per click.

PL

Plastikowy długopis z wewnętrzną tubą rotującą. Nove Swing pomoże Ci zaimponować klientom dzięki swojej oryginalnej technice wiadomości na kliknięcie.

IT

Penna a sfera in plastica con tubo rotante interno. Nove Swing ti aiuterà a impressionare i clienti con la sua tecnica originale di messaggi per clic.

FR

Stylo à bille en plastique avec tube rotatif interne. Nove Swing vous aidera à impressionner vos clients grâce à sa technique originale de messages par clic.

DE

Stylo à bille en plastique avec tube rotatif interne. Nove Swing vous aidera à impressionner vos clients grâce à sa technique originale de messages par clic.

ES

Bolígrafo de plástico con tubo giratorio interno. Nove Swing te ayudará a impresionar a los clientes con su técnica original de mensajes per clic.

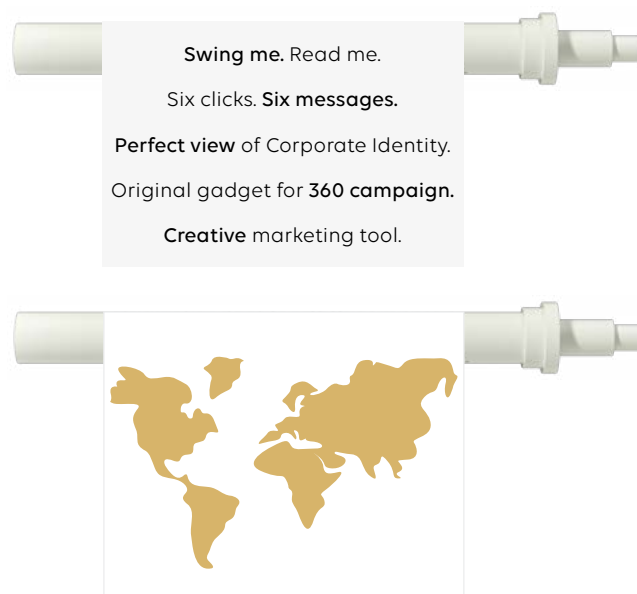

## Specification

|            |             |          |     |          |                           |           |                         |                  |           |
|------------|-------------|----------|-----|----------|---------------------------|-----------|-------------------------|------------------|-----------|
| Dimensions | 11 x 141 mm | Material | ABS | Finishes | Solid, Shiny, Transparent | Ink color | Blue, Black (on demand) | Packaging (pcs.) | 30 / 1200 |
|------------|-------------|----------|-----|----------|---------------------------|-----------|-------------------------|------------------|-----------|

## Branding options

### Clip

|                   |           |
|-------------------|-----------|
| Digital overprint | 6 x 28 mm |
| Pad printing      | 6 x 28 mm |

### Barrel

|                                     |            |
|-------------------------------------|------------|
| Digital overprint                   | 5 x 60 mm  |
| Pad printing                        | 5 x 45 mm  |
| Silkscreen printing 300° (Standard) | 30 x 40 mm |

### Rotation tube

|                                     |            |
|-------------------------------------|------------|
| Silkscreen printing 300° (Standard) | 17 x 40 mm |
|-------------------------------------|------------|

Discover the best **Lecce Pen**  
sell-out options!





**Be original**

*B1 presents an exquisite collection of high-quality gift writing instruments tailored to elevate the image of respectable brands.*



# HEXA

#hexagonal #novelties

Available in  
graphif tip

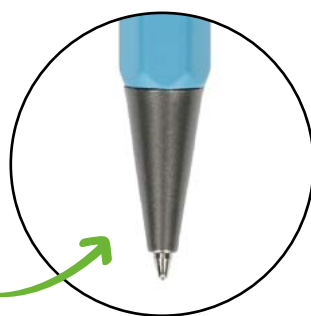

check it out!

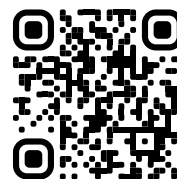

## New



Product code: 56001..

# Hexa New

## Colors



01

PMS White



120

PMS 012



05

PMS 1585



10

PMS 227

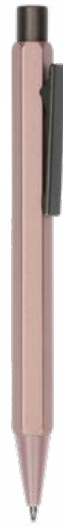

126

PMS 2587



132

PMS 368



18

PMS 347



136

PMS 2736



35

PMS Black

EN

An elegant and modern metal pen with a unique hexagonal-shaped body. The clip and button are in a stylish graphite color. The tip is available in two finishes: **color or graphite**. Combine functionality with exceptional design that captures attention. Perfect as a branding element for your company or a unique business gift.

PL

Elegancki i nowoczesny metalowy długopis z korpusem w unikalnym hexagonalnym kształcie. Klips i przycisk w stylowym grafitowym kolorze. Końcówka dostępna w dwóch rodzajach wykończenia: **kolor lub grafit**. Połącz funkcjonalność z wyjątkowym designem, który przyciąga uwagę. Idealny jako element identyfikacji wizualnej marki lub wyjątkowy upominek biznesowy.

IT

Una penna in metallo elegante e moderna con un corpo dal design unico a forma esagonale. La clip e il pulsante sono in un elegante colore grafite. La punta è disponibile in due finiture: **colore o grafite**. Combina funzionalità con un design eccezionale che cattura l'attenzione. Perfetta come elemento di identità visiva per il tuo marchio o come esclusivo regalo aziendale.

FR

Un stylo en métal élégant et moderne avec un corps unique en forme hexagonale. Le clip et le bouton sont d'une élégante **couleur graphite**. La pointe est disponible en deux finitions : **couleur ou graphite**. Alliez fonctionnalité et design exceptionnel qui attire l'attention. Parfait comme élément d'identité visuelle pour votre marque ou comme cadeau d'affaires unique.

DE

Ein eleganter und moderner Metallkugelschreiber mit einem einzigartigen hexagonalen Gehäuse. Der Clip und der Knopf sind in einem stilvollen Graphitton gehalten. Die Spitze ist in zwei Ausführungen erhältlich: **Farbe oder Graphit**. Vereinen Sie Funktionalität mit außergewöhnlichem Design, das Aufmerksamkeit erregt. Perfekt als Branding-Element für Ihre Marke oder als exklusives Geschäfts Geschenk.

ES

Un bolígrafo metálico elegante y moderno con un cuerpo único de forma hexagonal. El clip y el botón están en un elegante color grafito. La punta está disponible en dos acabados: **color o grafito**. Combina funcionalidad con un diseño excepcional que atrae todas las miradas. Perfecto como elemento de identidad visual para tu marca o como un exclusivo regalo empresarial.

## Specification

|            |             |                   |      |          |           |          |         |           |             |                  |          |
|------------|-------------|-------------------|------|----------|-----------|----------|---------|-----------|-------------|------------------|----------|
| Dimensions | 10 x 138 mm | Type of mechanism | Push | Material | Aluminium | Finishes | Lacquer | Ink color | Blue, Black | Packaging (pcs.) | 50 / 500 |
|------------|-------------|-------------------|------|----------|-----------|----------|---------|-----------|-------------|------------------|----------|

## Branding options

### Clip

|                 |             |
|-----------------|-------------|
| Laser engraving | 3,5 x 35 mm |
| Pad printing    | 4 x 45 mm   |

### Barrel

|                            |           |
|----------------------------|-----------|
| Laser engraving side A     | 50 x 4 mm |
| Laser engraving other side | 85 x 4 mm |
| Pad printing side A        | 30 x 4 mm |
| Pad printing other side    | 45 x 4 mm |





Be original

# MILLION MILLION Roller

*#bestseller #mpremium*



*check it out!*

table of contents

Product code: 35... | 35002/35

# MILLION | MILLION Roller

#bestseller #premium



35001/35 35001/35

Chrome Chrome

35101/35

Gold

35201/35

Rose Gold

35002/35

Chrome

EN

Premium metal ballpen available with chrome, gold or rose gold accessories and mirror engraving. Soft black barrel surface. Ink blue, black (on demand).

PL

Metalowy długopis klasy premium dostępny z dodatkami w kolorze chromowanym, złota lub różowego złota i lustrzanym grawerem. Softowana czarna powierzchnia korpusu. Niebieski tusz (czarny na zamówienie).

IT

Penna a sfera in metallo di qualità superiore disponibile con accessori in cromati, oro o oro rosa e incisione a specchio. Superficie del fusto soft touch nera. Inchiostro blu, nero (su richiesta).

FR

Stylo-bille en métal de première qualité disponible avec des accessoires en or ou en rose et une gravure en miroir effet. Surface du corps noire et douce. Encre bleue, noire (sur demande).

DE

Premium-Kugelschreiber aus Metall, erhältlich mit Gold- oder Roségold-Accessoires und Spiegelgravur. Weiche schwarze Laufoberfläche. Tintenblau, Schwarz (auf Anfrage).

ES

Bolígrafo metálico de alta calidad disponible con accesorios en oro u oro rosa y grabado en espejo. Superficie del cuerpo de color negro suave. Tinta azul, negra (bajo pedido).

Premium metal roller pen available with chrome accessories and mirror engraving. Soft black barrel surface. Ink blue, black (on demand).

Metalowy roller klasy premium dostępny z chromowanymi dodatkami i lustrzanym grawerem. Softowana czarna powierzchnia korpusu. Niebieski tusz (czarny na zamówienie).

Penna roller in metallo di qualità superiore, disponibile con accessori cromati e incisione a specchio. Superficie del fusto nera soft touch. Inchiostro blu, nero (su richiesta).

Stylo roller en métal de première qualité disponible avec des accessoires chromés et une gravure miroir. Surface du corps noire et souple. Encre bleue, noire (sur demande).

Hochwertiger Metallroller, erhältlich mit Chromzubehör und Spiegelgravur. Weiche schwarze Laufoberfläche. Tintenblau, Schwarz (auf Anfrage).

Bolígrafo roller metálico de alta calidad disponible con accesorios cromados y grabado en espejo. Superficie del cuerpo de color negro suave. Tinta azul, negra (bajo pedido).

## Specification

|            |               |                   |       |          |                 |          |           |           |                         |                  |          |
|------------|---------------|-------------------|-------|----------|-----------------|----------|-----------|-----------|-------------------------|------------------|----------|
| Dimensions | 12,8 x 142 mm | Type of mechanism | Twist | Material | Stainless steel | Finishes | SoftTouch | Ink color | Blue, Black (on demand) | Packaging (pcs.) | 50 / 500 |
|------------|---------------|-------------------|-------|----------|-----------------|----------|-----------|-----------|-------------------------|------------------|----------|

## Branding options

### Head

- Laser engraving "Mirror" Side B,C,D 5 x 20 mm
- Laser engraving „Mirror" 300° Side C 17 x 28 mm
- Pad printing Side B,C,D 5 x 20 mm

### Barrel

- Laser engraving "Mirror" All Side 6 x 45 mm
- Laser engraving „Mirror" 300° All Side 45 x 35 mm
- Silkscreen printing 300° (Standard) All Side 25 x 35 mm
- one color only

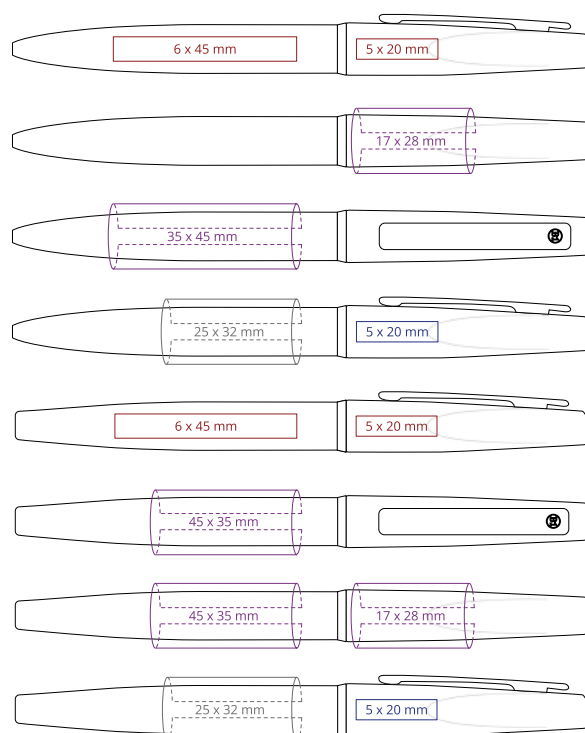



# IQ 32GB

*#premium #tech*

*check it out!*



*While stocks last*



*table of contents*

Product code: 1108/./32GB

# IQ 32GB

## Colors



**08**  
PMS 200



**24**  
PMS 2747

**EN**

**Intelligence - is your weapon!** The unique novelty combines electronic technologies of the new century and low-key style. This pen with **32GB mini-flash card** is a perfect business gift. Steel body with a soft coating provides comfortable tactile sensations. Stylish and functional.

**PL**

**Inteligencja - to Twoja broń!** Wyjątkowo łączy technologie nowego wieku i styl. **Długopis z 32GB pamięcią** sprawdza się jako doskonały "mini-biznes" lub prezent. Korpus ze stali z miękką powłoką zapewnia komfortowe doznania dotykowe. Stylowy i funkcjonalny.

**IT**

**L'intelligenza è la vostra arma!** Questa novità unica combina le tecnologie elettroniche del nuovo secolo e uno stil semplice. Questa penna con **una chiavetta da 32GB** è un perfetto regalo d'affari. Il corpo in acciaio con rivestimento soft touch offre una sensazione tattile confortevole. Elegante e funzionale.

**FR**

**L'intelligence est votre arme!** Cette nouveauté unique combine les technologies électroniques du nouveau siècle et un **clé USB de 32GB**. Go est un cadeau d'affaires idéal. Le corps en acier recouvert d'un revêtement souple procure des sensations tactiles agréables. Élégant et fonctionnel.

**DE**

**Intelligenz - das ist Ihre Waffe!** Einzigartige Kombination aus moderner Technologie und Stil. **Der Stift mit 32 GB Speicher** eignet sich perfekt als „Mini-Business“ oder Geschenk. Der weich beschichtete Stahlschaft sorgt für eine angenehme Haptik. Elegant und funktionell.

**ES**

**La inteligencia es tu arma** Esta novedad única combina las tecnologías electrónicas del nuevo siglo con un estilo discreto. Este bolígrafo con **una memoria de 32GB** es un regalo de empresa perfecto. El cuerpo de acero con revestimiento suave proporciona sensaciones táctiles confortables. Elegante y funcional.



## Specification

|                   |             |                          |       |                 |                                |                 |           |                  |      |                         |           |
|-------------------|-------------|--------------------------|-------|-----------------|--------------------------------|-----------------|-----------|------------------|------|-------------------------|-----------|
| <b>Dimensions</b> | 12 x 140 mm | <b>Type of mechanism</b> | Twist | <b>Material</b> | Brass with chrome undercoating | <b>Finishes</b> | SoftTouch | <b>Ink color</b> | Blue | <b>Packaging (pcs.)</b> | 100 / 200 |
|-------------------|-------------|--------------------------|-------|-----------------|--------------------------------|-----------------|-----------|------------------|------|-------------------------|-----------|

## Branding options

### Barrel

- Laser engraving „Mirror“ All Side **6 x 45 mm**
- Laser engraving 300° „ Mirror“ All Side **35 x 45 mm**
- Silkscreen printing 300° (Standard) All Side **35 x 45 mm**

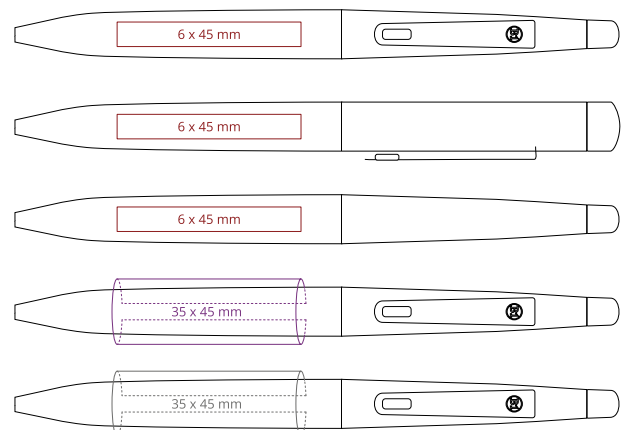



Be original

# MIRROR

*#bestseller #premium*

*check it out!*



table of contents

Product code: 38001/35 | 38002..

# MIRROR

## Colors



**35**  
PMS Black



**08**  
PMS 200



**24**  
PMS 2384



**26**  
PMS 7686



**30**  
PMS 424



**35**  
PMS Black

**EN**

**Mirror** - the body structure, unique soft surface and mirror engraving transform your logo! This solution impresses by minimalism.

**PL**

**Mirror** - kształt, aksamitna powierzchnia oraz grawer o efekcie lustra, uwidocznia Twoje logo. Takie rozwiązanie zachwyca minimalizmem.

**IT**

**Mirror** - la struttura del corpo, la superficie morbida unica e l'incisione a specchio trasformano il vostro logo! Questa soluzione colpisce per il suo minimalismo.

**FR**

**Mirror** - la structure du corps, la surface douce unique et la gravure effet miroir transforment votre logo ! Cette solution impressionne par son minimalisme.

**DE**

**Mirror** - die Form, die Soft-touch Oberfläche und die Gravur mit Spiegeleffekt machen Ihr Logo sichtbar. Diese Lösung begeistert durch ihren Minimalismus.

**ES**

**Mirror** - la estructura del cuerpo, la superficie blanda única y el grabado en espejo transforman su logotipo. Esta solución impresiona por su minimalismo.

## Specification

|                   |             |                          |       |                 |                                |                 |           |                  |                         |                         |                |
|-------------------|-------------|--------------------------|-------|-----------------|--------------------------------|-----------------|-----------|------------------|-------------------------|-------------------------|----------------|
| <b>Dimensions</b> | 11 x 140 mm | <b>Type of mechanism</b> | Twist | <b>Material</b> | Brass with chrome undercoating | <b>Finishes</b> | SoftTouch | <b>Ink color</b> | Blue, Black (on demand) | <b>Packaging (pcs.)</b> | 10 / 100 / 400 |
|-------------------|-------------|--------------------------|-------|-----------------|--------------------------------|-----------------|-----------|------------------|-------------------------|-------------------------|----------------|

## Branding options

### Head

Laser engraving "Mirror" Side B,C,D

Laser engraving „Mirror“ 300° Side C

Pad printing Side B,C,D



22 x 35 mm

5 x 30 mm



### Barrel

Laser engraving "Mirror" All Side

Laser engraving „Mirror“ 300° All Side

Silkscreen printing 300° (Standard) All Side

6 x 55 mm

33 x 55 mm

32 x 50 mm





Be original

# CLICKER Touch soft

*#bestseller*

*check it out!*



table of contents

Product code: 36002..

# CLICKER Touch Soft

## Colors



08

PMS 200



15

PMS 355



24

PMS 2384



26

PMS 654



30

PMS 410



35

PMS Black

EN

A simple classic line and a high quality of the product ensures its constant appeal regardless of the constantly changing trends in design. Offered in soft color palette emphasizes the credibility and professionalism of the company using it to promote its own brand. **Dual-purpose, designed for traditional writing as well as for use on mobile devices.**

PL

Prosta klasyczna linia oraz wysoka jakość produktu zapewnia jego stałą atrakcyjność niezależnie od stale zmieniających się trendów w designie. Oferowany w stonowanej paletce kolorystycznej podkreśla wiarygodność oraz profesjonalizm firmy wykorzystującej go do promocji własnej marki. **Dwufunkcyjny, przeznaczony do tradycyjnego pisania i użytkowania na urządzeniach mobilnych.**

IT

Una linea semplice e classica e l'alta qualità del prodotto ne garantiscono il costante appeal, indipendentemente dalle tendenze in continua evoluzione del design. L'offerta di una palette di colori tenui sottolinea la credibilità e la professionalità dell'azienda che la utilizza per promuovere il proprio marchio. **Doppio uso, progettato per la scrittura tradizionale e per l'uso su dispositivi mobili.**

FR

Une ligne simple et classique et la haute qualité du produit garantissent son attrait constant, indépendamment des tendances en constante évolution en matière de design. La palette de couleurs douces souligne la crédibilité et le professionnalisme de l'entreprise qui l'utilise pour promouvoir sa propre marque. **Double usage, conçu pour l'écriture traditionnelle et pour une utilisation sur des appareils mobiles.**

DE

Die schlichten, klassischen Linien und die hohe Qualität des Produkts sorgen dafür, dass es unabhängig von den sich ständig ändernden Designtrends weiterhin attraktiv bleibt. Mit seiner gedeckten Farbpalette unterstreicht es die Glaubwürdigkeit und Professionalität des Unternehmens, das es zur Förderung seiner Marke einsetzt. **Doppelfunktion, sowohl für traditionelles Schreiben als auch für die Verwendung auf mobilen Geräten.**

ES

Una línea clásica sencilla y la alta calidad del producto garantizan su atractivo constante, independientemente de los cambios constantes en las tendencias de diseño. Ofrecido en una paleta de colores suaves, subraya la credibilidad y profesionalidad de la empresa que lo utiliza para promocionar su propia marca. **Doble propósito, diseñado tanto para la escritura tradicional como para su uso en dispositivos móviles.**

## Specification

|            |             |                   |       |          |                       |          |           |           |                         |                  |          |
|------------|-------------|-------------------|-------|----------|-----------------------|----------|-----------|-----------|-------------------------|------------------|----------|
| Dimensions | 10 x 141 mm | Type of mechanism | Click | Material | Aluminium with chrome | Finishes | SoftTouch | Ink color | Blue, Black (on demand) | Packaging (pcs.) | 50 / 200 |
|------------|-------------|-------------------|-------|----------|-----------------------|----------|-----------|-----------|-------------------------|------------------|----------|

## Branding options

### Head

Laser engraving "Mirror" Side B,C,D

Laser engraving „Mirror" 300° Side C

Pad printing Side B,C,D

5 x 40 mm

22 x 40 mm

5 x 40 mm

### Barrel

Laser engraving "Mirror" All Side

Laser engraving „Mirror" 300° All Side

Pad printing Side All Side

Silkscreen printing 300° (Standard) All Side

5 x 45 mm

27 x 45 mm

5 x 40 mm

27 x 45 mm

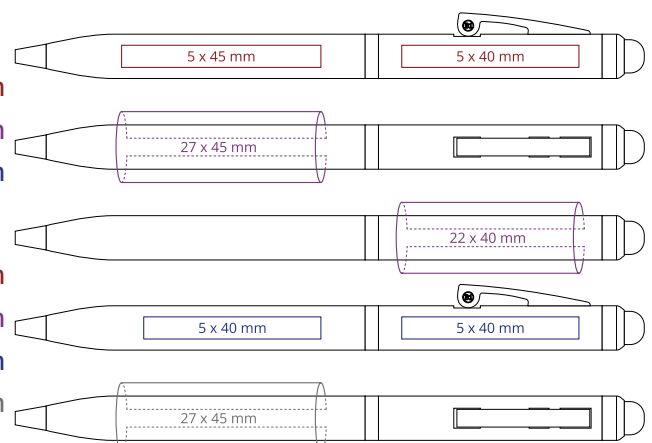





Be original

# TOUCH WRITER

## Soft

*check it out!*



*table of contents*

Product code: 1105G..

# TOUCH WRITER Soft

## Colors



**24**  
PMS 2747



**30**  
PMS 424



**35**  
PMS Black

**EN**

Dual-purpose pen **TouchWriter™ Soft** with silk surface. Traditional pen on one hand, and on the other – precise tool allowing effective and fast work on such mobile devices as smartphones and tablets equipped with touch screen.

**PL**

Dwufunkcyjny długopis **TuchWriter™ Soft** z aksamitną powierzchnią w dotyku. Z jednej strony tradycyjny długopis, z drugiej precyzyjne narzędzie pozwalające na efektywną i szybką pracę na wszystkich urządzeniach mobilnych, smartfonach, tabletach wyposażonych w ekran dotykowy.

**IT**

Penna a doppio uso **TouchWriter™ soft con finitura soft touch**. Da un lato una penna tradizionale, dall'altro uno strumento preciso che consente di lavorare in modo efficace e veloce su dispositivi mobili come smartphone e tablet dotati di touch screen.

**FR**

Stylo à double usage **TouchWriter™ Soft** avec finition gommée. Stylo traditionnel d'une part, et d'autre part - outil précis permettant un travail efficace et rapide sur des appareils mobiles tels que les smartphones et les tablettes équipés d'un écran tactile.

**DE**

Der **TouchWriter™ Soft-Kugelschreiber** mit Doppelfunktion und samtiger Haptik. Auf der einen Seite ein traditioneller Kugelschreiber, auf der anderen Seite ein Präzisionswerkzeug, mit dem Sie effektiv und schnell auf allen mobilen Geräten, Smartphones, Tablets mit Touchscreen arbeiten können.

**ES**

Bolígrafo de doble uso **TouchWriter™ Soft** con acabado soft touch. Por un lado, es un bolígrafo tradicional y, por otro, una herramienta precisa que permite trabajar de forma rápida y eficaz en dispositivos móviles como smartphones y tabletas equipados con pantalla táctil.

## Specification

|                   |            |                          |       |                 |                                |                 |           |                  |      |                         |          |
|-------------------|------------|--------------------------|-------|-----------------|--------------------------------|-----------------|-----------|------------------|------|-------------------------|----------|
| <b>Dimensions</b> | 7 x 137 mm | <b>Type of mechanism</b> | Twist | <b>Material</b> | Brass with chrome undercoating | <b>Finishes</b> | SoftTouch | <b>Ink color</b> | Blue | <b>Packaging (pcs.)</b> | 50 / 500 |
|-------------------|------------|--------------------------|-------|-----------------|--------------------------------|-----------------|-----------|------------------|------|-------------------------|----------|

## Branding options

### Head

Laser engraving "Mirror" Side B,C,D **4,5 x 44 mm**

Laser engraving „Mirror" 300° Side C **18 x 42 mm**

Pad printing Side B,C,D **4 x 40 mm**

**NOT RECOMMENDED ON BLACK PEN**

### Barrel

Laser engraving "Mirror" All Side **4,5 x 50 mm**

Laser engraving „Mirror" 300° All Side **20 x 50 mm**

Silkscreen printing 300° (Standard) All Side **18 x 50 mm**

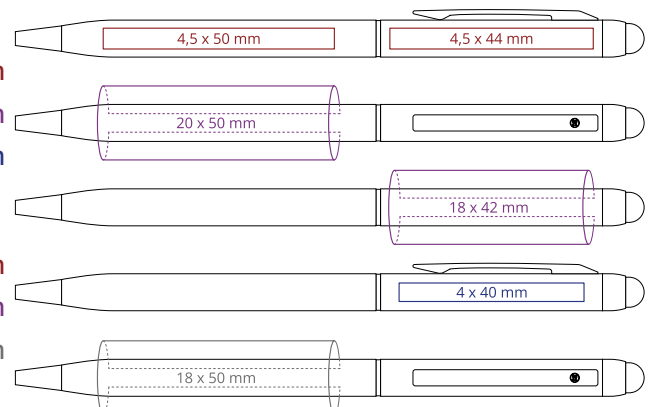



# PRESS

*check it out!*



*table of contents*

Product code: 55501..

# PRESS

## Colors



**05**

PMS 2026



**08**

PMS 4059



**23**

PMS 283



**25**

PMS 654



**30**

PMS 410



**35**

PMS Black

**EN**

Ballpen with push mechanism. **Soft barrel surface and oxidated surface in GUN type accessories.** With unique clip design. Ink blue, black (on demand). available in 6 colors.

**PL**

Długopis z mechanizmem przyciskowym. **Softowana powierzchnia korpusu z dodatkami w kolorze grafitowym.** Unikalna konstrukcja klipsa. Niebieski tusz, czarny na zamówienie. Dostępny w 6-ciu kolorach.

**IT**

Penna a sfera con meccanismo a pressione. **Superficie gommatata del fusto e accessori colore canna di fucile.** Con design unico della clip. Inchiostro blu, nero (su richiesta). Disponibile in 6 colori.

**FR**

Stylo-bille avec mécanisme à poussoir. **Surface du corps gommé et accessoires gris anthracite.** Avec un design unique de du clip. Encre bleue, noire (sur demande). Disponible en 6 couleurs.

**DE**

Kugelschreiber mit Druckmechanismus. **Weiche Schaftoberfläche und oxydierte Oberfläche im GUN-Typ Zubehör.** Mit einzigartigem Clip-Design. Tinte blau, schwarz (auf Anfrage). Erhältlich in 6 Farben.

**ES**

Bolígrafo con mecanismo de empuje mecanismo pulsador. **Cuerpo con acabado soft touch y detalles gris oscuro.** Con diseño de clip único. Tinta azul, negra (bajo demanda). Disponible en 6 colores.

## Specification

| Dimensions | 10 x 136 mm | Type of mechanism | Push | Material | Aluminium | Finishes | SoftTouch | Ink color | Blue, Black (on demand) | Packaging (pcs.) | 50 / 500 |
|------------|-------------|-------------------|------|----------|-----------|----------|-----------|-----------|-------------------------|------------------|----------|
|------------|-------------|-------------------|------|----------|-----------|----------|-----------|-----------|-------------------------|------------------|----------|

## Branding options

### Clip

Laser engraving Side A

3,5 x 35 mm

### Barrel

Laser engraving All Side

6 x 45 mm

Laser engraving 300° All Side

28 x 45 mm

Pad printing All Side

4 x 45 mm

**NOT RECOMMENDED ON BLACK PEN**

Silkscreen printing 300° (Standard)

25 x 40 mm

**NOT RECOMMENDED ON SOFT SURFACE**

Laser engraving (Special) Side B,C,D

6 x 95 mm

Laser engraving 300° (Special) Side C

21 x 95 mm

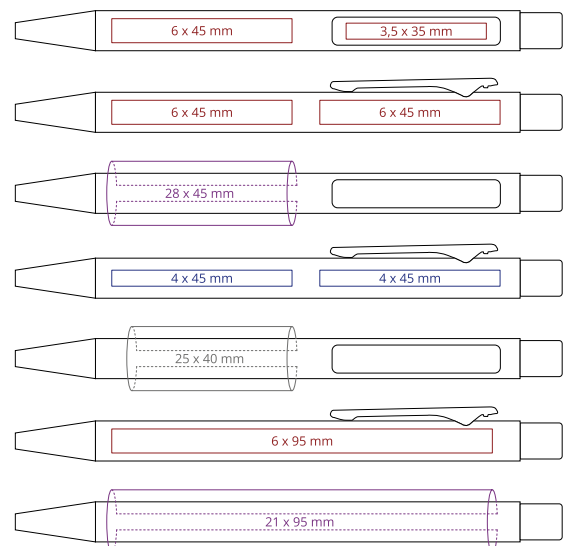



# PRESS Roller

*check it out!*



*See video*

Product code: 55502..

check it out!

# PRESS Roller

## Colors



05

PMS 2026



08

PMS 4059



23

PMS 283



25

PMS 654



30

PMS 410



35

PMS Black

EN

Metal roller pen. Soft barrel surface and oxydated surface in GUN type accessories. With unique clip design with cap. Blue or black ink. Available in 6 colors.

PL

Roller metalowy. Softowana powierzchnia korpusu z dodatkami w kolorze graficznym. Unikalna konstrukcja klipsa. Niebieski lub czarny tusz. Dostępny w 6 kolorach.

IT

Penna roller in metallo. Superficie gommata del fusto e accessori colore canna di fucile. Con design unico della clip. Inchiostro blu o nero. Disponibile in 6 colori.

FR

Stylo roller en métal. Surface du corps souple et corps gommé et accessoires gris anthracite. Clip au design unique. Encre bleue ou noire. Disponible en 6 couleurs.

DE

Metallroller. Weiche Laufoberfläche und oxydierte Oberfläche bei GUN-Zubehör. Mit einzigartigem Clip-Design. Blaue oder schwarze Tinte. Erhältlich in 6 Farben.

ES

Bolígrafo roller metálico. Superficie suave del cuerpo y superficie oxidada en accesorios tipo GUN. Con clip de diseño exclusivo. Tinta azul o negra. Disponible en 6 colores.

## Specification

|            |             |                   |      |          |           |          |           |           |                         |                  |          |
|------------|-------------|-------------------|------|----------|-----------|----------|-----------|-----------|-------------------------|------------------|----------|
| Dimensions | 10 x 136 mm | Type of mechanism | Push | Material | Aluminium | Finishes | SoftTouch | Ink color | Blue, Black (on demand) | Packaging (pcs.) | 50 / 500 |
|------------|-------------|-------------------|------|----------|-----------|----------|-----------|-----------|-------------------------|------------------|----------|

## Branding options

### Clip

Laser engraving Side A

### Head

Laser engraving Side B,C,D

Laser engraving 300° Side C

Pad printing Side B,C,D

### Barrel

Laser engraving All Side

Laser engraving 300° All Side

Pad printing All Side

Silkscreen printing 300° (Standard) All Side

NOT RECOMMENDED ON SOFT SURFACE

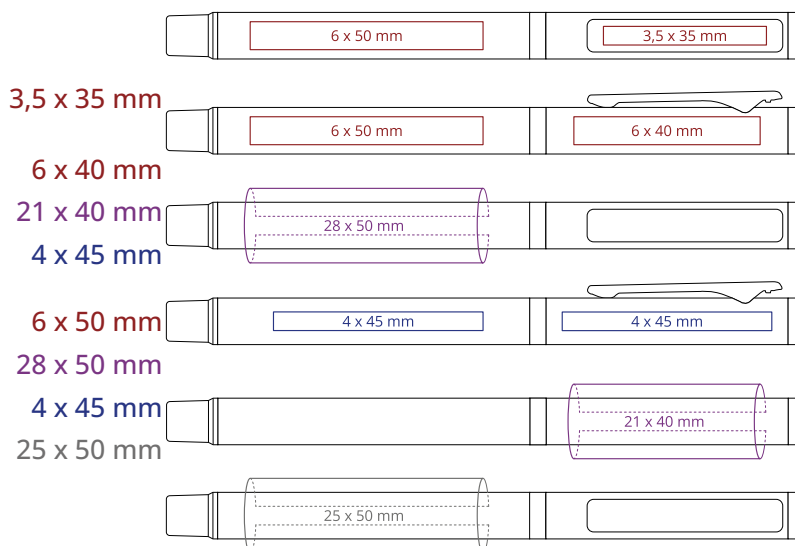



Be original

# PRESS Bi-color



table of contents

Product code: 55503..

# PRESS Bi-color

## Colors



**05**  
PMS 165



**08**  
PMS 185



**23**  
PMS 7485



**25**  
PMS 7689



**30**  
PMS 2368



**35**  
PMS 871

**EN**

Ballpen with push mechanism. Soft black barrel surface and black accessories. **Bi-color engraving with mirror effect.** The stylus color matches the engraving color. Ink blue, black (on demand). Available in 6 colors.

**PL**

Długopis z mechanizmem przyciskowym. Softowana czarna powierzchnia korpusu i czarne dodatki. **Dwukolorowy graver z efektem lustra.** Końcówka dotykowa w kolorze pasującym do graweru. Niebieski tusz (czarny na zamówienie). Dostępny w 6 kolorach.

**IT**

Penna a sfera con meccanismo a pressione. Superficie del fusto nera soft touch e accessori neri. **Incisione bicolore con effetto specchio.** Il colore gommino touch corrisponde al colore dell'incisione. Inchiostro blu, nero (su richiesta). Disponibile in 6 colori.

**FR**

Stylo-bille avec mécanisme à pousser. Surface du corps gommée et accessoires noirs. **Gravure bicolore avec effet miroir.** La couleur du stylet correspond à la couleur de la gravure. Encre bleue, noire (sur demande). Disponible en 6 couleurs.

**DE**

Kugelschreiber mit Druckmechanismus. Weiche schwarze Laufoberfläche und schwarzes Zubehör. **Zweifarbige Gravur mit Spiegeleffekt.** Die Stiftfarbe entspricht der Gravurfarbe. Tintenblau, Schwarz (auf Anfrage). Erhältlich in 6 Farben.

**ES**

Bolígrafo con mecanismo pulsador. Superficie del cuerpo de color negro soft touch y accesorios negros. **Grabado bicolore con efecto espejo.** El color del touch pad coincide con el color del grabado. Tinta azul, negra (bajo pedido). Disponible en 6 colores.

## Specification

| Dimensions | 10 x 142 mm | Type of mechanism | Push | Material | Aluminium | Finishes | SoftTouch | Ink color | Blue, Black (on demand) | Packaging (pcs.) | 50 / 500 |
|------------|-------------|-------------------|------|----------|-----------|----------|-----------|-----------|-------------------------|------------------|----------|
|------------|-------------|-------------------|------|----------|-----------|----------|-----------|-----------|-------------------------|------------------|----------|

## Branding options

### Clip

Laser engraving Side A **3,5 x 35 mm**

### Barrel

Laser engraving „Mirror“ All Side **6 x 45 mm**

Laser engraving 300° „Mirror“ All Side **28 x 45 mm**

Silkscreen printing 300° (Standard) All Side **25 x 40 mm**

*NOT RECOMMENDED ON SOFT SURFACE*

Pad printing All Side **4 x 45 mm**

*NOT RECOMMENDED ON BLACK PEN*

Laser engraving „Mirror“ (special) Side B,C,D **6 x 95 mm**

Laser engraving 300° „Mirror“ (special) Side C **21 x 95 mm**

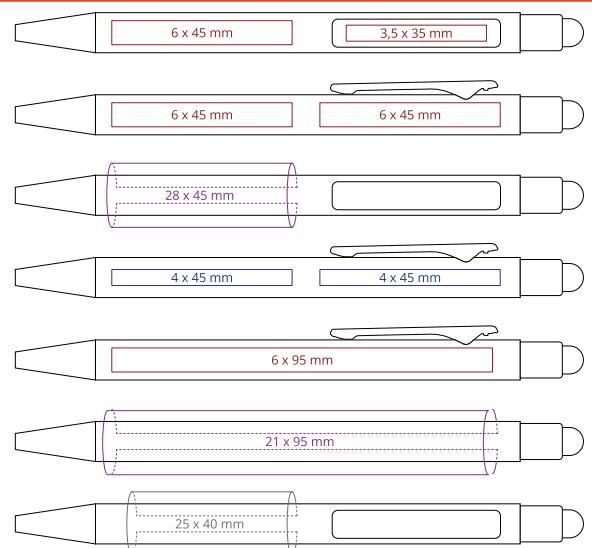





Be original

# ELLE Metal Touch

check it out!

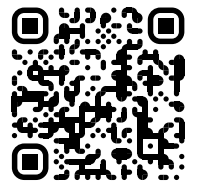

table of contents

Product code: 182MG..

# ELLE Metal Touch

## Colors



**06**  
PMS 173



**08**  
PMS 200



**22**  
PMS 7461



**25**  
PMS 4142



**30**  
PMS 425



**35**  
PMS Black

EN

Metal ballpen with touch stylus, soft surface and chrome details.

PL

Długopis metalowy z końcówką dotykową, softowaną powierzchnią i chromowanymi dodatkami.

IT

Penna a sfera in metallo con gommino touch, finitura gommata soft.

FR

Stylo-bille en métal avec stylet tactile, surface soft touch et détails chromés.

DE

Metalstift mit fühlbarer Spitze, weicher Oberfläche und verchromtem Zubehör.

ES

Bolígrafo metálico con puntero táctil, superficie suave y detalles cromados.

## Specification

|            |             |                   |      |          |           |          |           |           |      |                  |          |
|------------|-------------|-------------------|------|----------|-----------|----------|-----------|-----------|------|------------------|----------|
| Dimensions | 10 x 145 mm | Type of mechanism | Push | Material | Aluminium | Finishes | SoftTouch | Ink color | Blue | Packaging (pcs.) | 50 / 500 |
|------------|-------------|-------------------|------|----------|-----------|----------|-----------|-----------|------|------------------|----------|

## Branding options

### Barrel

Laser engraving All Side

Laser engraving 300° All Side

Pad printing Side B,D

Laser engraving 300° (special) Side C

Silkscreen printing 300° (Standard)

NOT RECOMMENDED ON SOFT SURFACE

6 x 50 / 6 x 90 mm

30 x 60 mm

4 x 45 mm

30 x 60 mm

22 x 50 mm

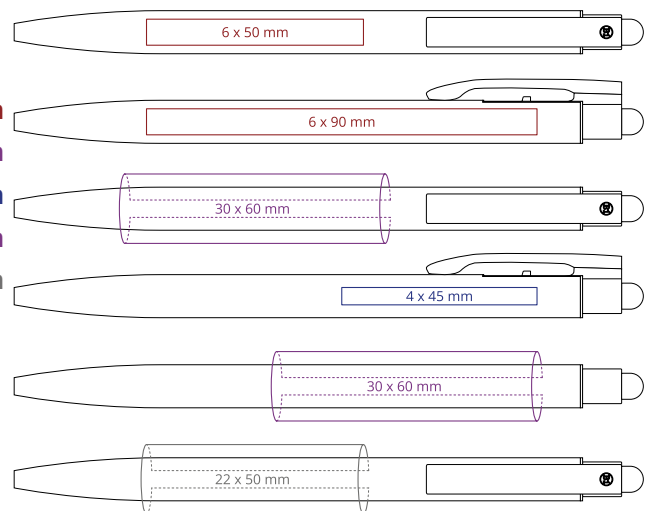

table of contents



# ELLE Metal Touch Graphite

*check it out!*



Be original

table of contents

Product code: 182MGUNG..

# ELLE Metal Touch Graphite

## Colors



**06**  
PMS 173



**08**  
PMS 200



**18**  
PMS 348



**22**  
PMS 7461



**25**  
PMS 4142



**30**  
PMS 425



**35**  
PMS Black

**EN**

Metal ballpen with touch stylus, soft surface and details in graphite color.

**PL**

Długopis metalowy z końcówką dotykową, softowaną powierzchnią i dodatkami w kolorze grafitowym.

**IT**

Penna a sfera in metallo con gommino touch, scorporo gommato e dettagli in colore grafite.

**FR**

Stylo-bille en métal avec stylet tactile, surface gommée et détails en couleur graphite.

**DE**

Metallstift mit fühlbarer Spitze, weicher Oberfläche und verchromtem Zubehör.

**ES**

Bolígrafo metálico con puntero táctil, cuerpo soft suave y detalles en color grafito.

## Specification

|            |             |                   |      |          |           |          |           |           |       |                  |          |
|------------|-------------|-------------------|------|----------|-----------|----------|-----------|-----------|-------|------------------|----------|
| Dimensions | 10 x 145 mm | Type of mechanism | Push | Material | Aluminium | Finishes | SoftTouch | Ink color | Black | Packaging (pcs.) | 50 / 500 |
|------------|-------------|-------------------|------|----------|-----------|----------|-----------|-----------|-------|------------------|----------|

## Branding options

### Barrel

Laser engraving All Side

Laser engraving 300° All Side

Pad printing Side B,D

Laser engraving 300° (special) Side C

Silkscreen printing 300° (Standard)

NOT RECOMMENDED ON SOFT SURFACE

6 x 50 / 6 x 90 mm

30 x 60 mm

4 x 45 mm

30 x 60 mm

22 x 50 mm

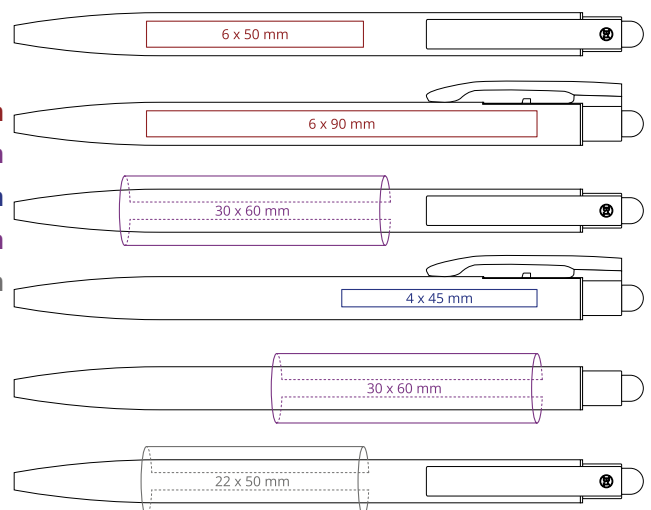

table of contents



# CLICKER Touch

*check it out!*



Be original

*table of contents*

Product code: 36001..

# CLICKER Touch

## Colors



**01**  
PMS White



**24**  
PMS Reflex Blue



**30**  
PMS 410



**35**  
PMS Black



**47**  
PMS Silver

**EN**  
A simple classic line and a high quality of the product ensures its constant appeal regardless of the constantly changing trends in design. Offered in soft color palette emphasizes the credibility and professionalism of the company using it to promote its own brand. **Dual-purpose, designed for traditional writing as well as for use on mobile devices.**

**PL**  
Prosta klasyczna linia oraz wysoka jakość produktu zapewnia jego stałą atrakcyjność niezależnie od stale zmieniających się trendów w designie. Oferowany w stonowanej paletce kolorystycznej podkreśla wiarygodność oraz profesjonalizm firmy wykorzystującej go do promocji własnej marki. **Dwufunkcyjny, przeznaczony do tradycyjnego pisania i użytkowania na urządzeniach mobilnych.**

**IT**  
Una linea semplice e classica e l'alta qualità del prodotto ne garantiscono il costante appeal, indipendentemente dalle tendenze in continua evoluzione del design. L'offerta di una palette di colori tenui sottolinea la credibilità e la professionalità dell'azienda che la utilizza per promuovere il proprio marchio. **Doppio uso, progettato per la scrittura tradizionale e per l'uso su dispositivi mobili.**

**FR**  
Une ligne simple et classique et la haute qualité du produit garantissent son attrait constant, indépendamment des tendances en constante évolution en matière de design. La palette de couleurs douces souligne la crédibilité et le professionnalisme de l'entreprise qui l'utilise pour promouvoir sa propre marque. **Double usage, conçu pour l'écriture traditionnelle et pour une utilisation sur des appareils mobiles.**

**DE**  
Die schlichten, klassischen Linien und die hohe Qualität des Produkts sorgen dafür, dass es unabhängig von den sich ständig ändernden Designtrends weiterhin attraktiv bleibt. Mit seiner dezenten Farbpalette unterstreicht es die Glaubwürdigkeit und Professionalität des Unternehmens, das es zur Förderung seiner Marke einsetzt. **Doppelt verwendbar, sowohl für traditionelles Schreiben als auch für die Nutzung auf mobilen Geräten.**

**ES**  
Una línea clásica sencilla y la alta calidad del producto garantizan su atractivo constante, independientemente de los cambios constantes en las tendencias de diseño. Ofrecido en una paleta de colores suaves, subraya la credibilidad y profesionalidad de la empresa que lo utiliza para promocionar su propia marca. **Doble propósito, diseñado tanto para la escritura tradicional como para su uso en dispositivos móviles.**

## Specification

|                   |             |                          |       |                 |           |                 |         |                  |                         |                         |          |
|-------------------|-------------|--------------------------|-------|-----------------|-----------|-----------------|---------|------------------|-------------------------|-------------------------|----------|
| <b>Dimensions</b> | 10 x 141 mm | <b>Type of mechanism</b> | Click | <b>Material</b> | Aluminium | <b>Finishes</b> | Lacquer | <b>Ink color</b> | Blue, Black (on demand) | <b>Packaging (pcs.)</b> | 50 / 200 |
|-------------------|-------------|--------------------------|-------|-----------------|-----------|-----------------|---------|------------------|-------------------------|-------------------------|----------|

## Branding options

### Head

Laser engraving Side B,C,D

Pad printing Side B,C,D

Laser engraving 300° (Special) Side C

5 x 40 mm

5 x 40 mm

22 x 40 mm

### Barrel

Laser engraving All Side

Laser engraving 300° Side A

Pad printing All Side

Silkscreen printing 300° (Standard) All Side

5 x 45 mm

28 x 45 mm

5 x 40 mm

27 x 45 mm

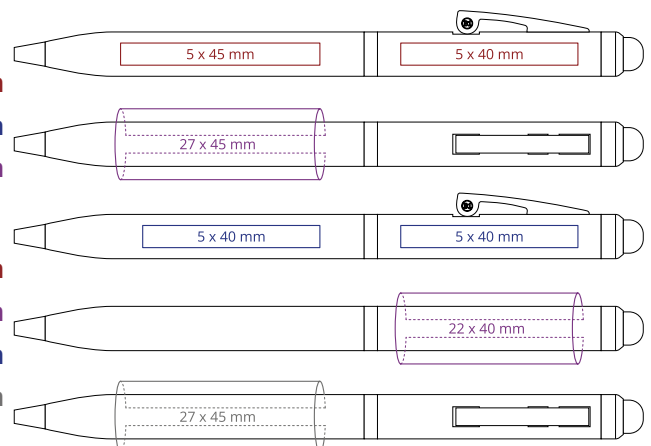



# FORCE

*check it out!*



*While stocks last*



Be original

*table of contents*

Product code: 40301..

# FORCE

## Colors



**24**  
PMS 653



**35**  
PMS Black



**47**  
PMS 422



**15**  
PMS 7741  
*Sell - out!*

**EN**

**Force** - this pen with its dynamic shape and contemporary style perfectly suits in any business. Available in colors with silver accessories. Most popular in the hi-tech industry with those who want to be at the forefront of technology.

**PL**

**Force** - długopis o dynamicznym kształcie i nowoczesnej stylistyce doskonale sprawdza w każdym biznesie. Dostępny w stonowanych kolorach ze srebrnymi dodatkami. Największym zainteresowaniem cieszy się w branżach technicznych, gdzie wykorzystuje się nowe technologie.

**IT**

**Force** - questa penna dalla forma dinamica e dallo stile contemporaneo si adatta perfettamente a qualsiasi attività commerciale. Disponibile nei colori con accessori in argento. Molto apprezzata nel settore hi-tech da chi vuole essere all'avanguardia della tecnologia.

**FR**

**Force** - ce stylo à la forme dynamique et au style contemporain convient parfaitement à toutes les entreprises. Disponible en couleurs avec des accessoires argentés. Très populaire dans l'industrie de la haute technologie auprès de ceux qui veulent être à la pointe de la technologie.

**DE**

**Force** - ein Stift mit dynamischer Form und modernem Stil, perfekt für jedes Unternehmen. Erhältlich in gedeckten Farben mit silbernen Accessoires. Er ist besonders beliebt in technischen Branchen, in denen neue Technologien eingesetzt werden.

**ES**

**Force** - este bolígrafo de forma dinámica y estilo contemporáneo encaja perfectamente en cualquier negocio. Disponible en colores con accesorios plateados. Más popular en la industria de alta tecnología con aquellos que quieren estar a la vanguardia de la tecnología.

## Specification

|                   |             |                          |       |                 |           |                 |              |                  |                         |                         |          |
|-------------------|-------------|--------------------------|-------|-----------------|-----------|-----------------|--------------|------------------|-------------------------|-------------------------|----------|
| <b>Dimensions</b> | 10 x 140 mm | <b>Type of mechanism</b> | Click | <b>Material</b> | Aluminium | <b>Finishes</b> | Lacquer matt | <b>Ink color</b> | Blue, Black (on demand) | <b>Packaging (pcs.)</b> | 50 / 200 |
|-------------------|-------------|--------------------------|-------|-----------------|-----------|-----------------|--------------|------------------|-------------------------|-------------------------|----------|

## Branding options

### Barrel

Laser engraving All Side

Laser engraving 300° All Side

Pad printing All Side

Silkscreen printing 300° (Standard) All Side







# TATTOO

check it out!



table of contents

Product code: 40308..

# TATTOO

## Colors



**03**  
PMS 103



**05**  
PMS 1585



**08**  
PMS 180



**18**  
PMS 347



**22**  
PMS 298



**25**  
PMS 2726



**11**  
PMS 2081  
*Sell - out!*

**EN**

**Tattoo** - unique in shape and color. Simplicity and attractive look are its basic advantages, additional WOW effect of the BI-COLOR engraving makes it effective ambassador of Your brand. Unique characteristics the colorful grip which no other models have.

**PL**

**Tattoo** - wyjątkowy w swoim kształcie i kolorze. Prostota i atrakcyjny wygląd to jego podstawowe zalety, a dodatkowy efekt WOW dwukolorowego graweru czyni go skutecznym ambasadorem Twojej marki.

**IT**

**Tattoo** - unico per forma e colore. La semplicità e l'aspetto attraente sono i suoi vantaggi fondamentali, mentre l'effetto WOW dell'incisione BI-COLOR lo rende un efficace ambasciatore del vostro marchio.

**FR**

**Tattoo** - unique par sa forme et sa couleur. La simplicité et l'aspect attrayant sont ses principaux avantages, l'effet WOW supplémentaire de la gravure BI-COLOR en fait un ambassadeur efficace de votre marque.

**DE**

**Tattoo** - einzigartig in Form und Farbe. Schlichtheit und ein attraktives Design sind seine Hauptvorteile, und der zusätzliche WOW-Effekt der zweifarbigen Gravur macht es zu einem wirkungsvollen Botschafter Ihrer Marke.

**ES**

**Tattoo** - único en forma y color. La simplicidad y el aspecto atractivo son sus ventajas básicas, el efecto WOW adicional del grabado BI-COLOR lo convierte en un eficaz embajador de Su marca.

## Specification

|                   |             |                          |       |                 |           |                 |         |                  |                         |                         |          |
|-------------------|-------------|--------------------------|-------|-----------------|-----------|-----------------|---------|------------------|-------------------------|-------------------------|----------|
| <b>Dimensions</b> | 10 x 140 mm | <b>Type of mechanism</b> | Click | <b>Material</b> | Aluminium | <b>Finishes</b> | Lacquer | <b>Ink color</b> | Blue, Black (on demand) | <b>Packaging (pcs.)</b> | 50 / 200 |
|-------------------|-------------|--------------------------|-------|-----------------|-----------|-----------------|---------|------------------|-------------------------|-------------------------|----------|

## Branding options

### Barrel

Laser engraving Side B,C,D

Laser engraving 300° Side C

Pad printing Side B,C,D

Laser engraving 300° (Special) All Side

6 x 75 mm

22 x 60 mm

4 x 45 mm

22 x 28 mm

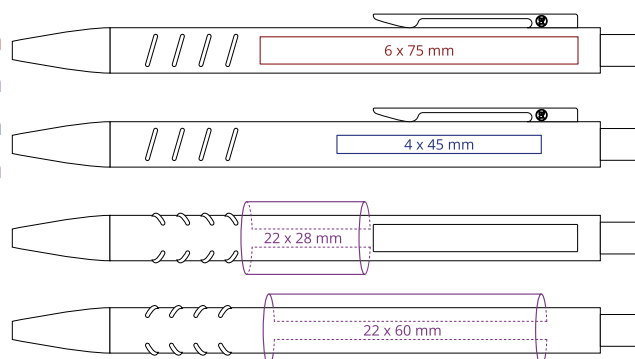



Be original

# IMPRESS

*#bestseller*

*check it out!*



*table of contents*

Product code: 37001..

# IMPRESS

## Colors



|   |  |  |   |   |  |
|---|--|--|---|---|--|
| <p><b>EN</b></p> <p><b>Impress</b> - a simple, classic line in a wide range of colors. Its black finish is very stylish. It's an attractive gadget for all modern brands.</p> | <p><b>PL</b></p> <p><b>Impress</b> - prosta, klasyczna linia oraz szeroka gama kolorystyczna to atrybuty modelu. Czarne wykończenia dodają mu wyjątkowego stylu. Atrakcyjny gadżet dla nowoczesnych marek.</p> | <p><b>IT</b></p> <p><b>Impress</b> - una linea semplice e classica in un'ampia gamma di colori. La sua finitura nera è molto elegante. È un gadget attraente per tutti i marchi moderni.</p> | <p><b>FR</b></p> <p><b>Impress</b> - une ligne simple et classique dans une large gamme de couleurs. Sa finition noire est très élégante. C'est un gadget attrayant pour toutes les marques modernes.</p> | <p><b>DE</b></p> <p><b>Impress</b> - einfache, klassische Linien und eine breite Farbpalette sind die Attribute dieses Modells. Die schwarze Zierleiste unterstreicht seinen einzigartigen Stil. Ein attraktives Gadget für moderne Marken.</p> | <p><b>ES</b></p> <p><b>Impress</b> - una línea sencilla y clásica en una amplia gama de colores. Su acabado en negro es muy elegante. Es un gadget atractivo para todas las marcas modernas.</p> |
|---|--|--|---|---|--|

## Specification

|                   |             |                          |       |                 |           |                 |         |                  |                         |                         |          |
|-------------------|-------------|--------------------------|-------|-----------------|-----------|-----------------|---------|------------------|-------------------------|-------------------------|----------|
| <b>Dimensions</b> | 10 x 145 mm | <b>Type of mechanism</b> | Click | <b>Material</b> | Aluminium | <b>Finishes</b> | Lacquer | <b>Ink color</b> | Blue, Black (on demand) | <b>Packaging (pcs.)</b> | 50 / 500 |
|-------------------|-------------|--------------------------|-------|-----------------|-----------|-----------------|---------|------------------|-------------------------|-------------------------|----------|

## Branding options

### Barrel

- |  |                     |
|--|---------------------|
| Laser engraving All Side                     | 6 x 65 / 6 x 100 mm |
| Laser engraving 300° All Side                | 28 x 65 mm          |
| Pad printing Side B,C,D                      | 5 x 45 mm           |
| Silkscreen printing 300° (Standard) All Side | 27 x 50 mm          |
| Laser engraving 300° (Special) Side C        | 22 x 100 mm         |

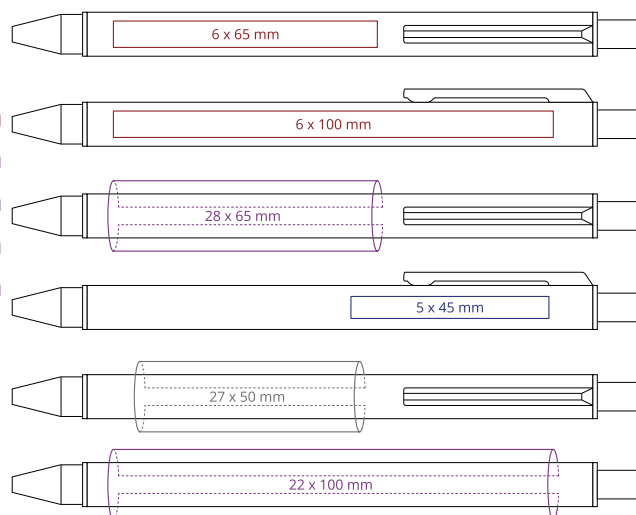



**B1** Touch Writer

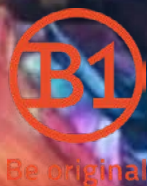

Be original

# TOUCH WRITER

*#bestseller*

*check it out!*



*table of contents*

Product code: 1102..

# TOUCH WRITER

## Colors



|  |  |  |  |  |   |
|--|--|--|--|--|---|
| <p><b>EN</b></p> <p>Following the latest trends B1 presents the new generation of bifunctional pen to use with mobile devices with touch screens, smartphones, tablet and traditional way. <b>TouchWriter™</b> can be used to click down to the very last pixel, to take electronic notes from one side and for the other side to the paper writing.</p> | <p><b>PL</b></p> <p>B1 prezentuje dwufunkcyjny długopis nowej generacji - <b>TouchWriter™</b>. Z jednej strony tradycyjny długopis, z drugiej precyzyjne narzędzie pozwalające na efektywną i szybką pracę na wszystkich urządzeniach mobilnych, smartfonach, tabletach wyposażonych w ekran dotykowy.</p> | <p><b>IT</b></p> <p>Seguendo le ultime tendenze B1 presenta la nuova generazione di penna bifunzionale da utilizzare con dispositivi mobili con touch screen, smartphone, tablet e in modo tradizionale. <b>TouchWriter™</b> può essere utilizzata per cliccare fino all'ultimo pixel, per prendere appunti elettronici da un lato e per scrivere su carta dall'altro.</p> | <p><b>FR</b></p> <p>Suivant les dernières tendances, B1 présente la nouvelle génération de stylo bifonctionnel à utiliser avec les appareils mobiles à écrans tactiles, les smartphones, les tablettes et de manière traditionnelle. <b>TouchWriter™</b> peut être utilisé pour cliquer jusqu'au dernier pixel, pour prendre des notes électroniques d'un côté et pour l'autre côté à l'écriture sur papier.</p> | <p><b>DE</b></p> <p>B1 präsentiert einen Stift der neuen Generation mit Doppel-funktion - den <b>TouchWriter™</b>. Auf der einen Seite ein traditioneller Kugelschreiber, auf der anderen Seite ein Präzisionswerkzeug für effektives und schnelles Arbeiten auf allen mobilen Geräten, Smartphones, Tablets, die mit einem Touchscreen ausgestattet sind.</p> | <p><b>ES</b></p> <p>Siguiendo las últimas tendencias B1 presenta la nueva generación de bolígrafo bifuncional para utilizar con dispositivos móviles con pantallas táctiles, smartphones, tablet y de forma tradicional. <b>TouchWriter™</b> se puede utilizar para hacer clic hasta el último píxel, para tomar notas electrónicas de un lado y para el otro lado a la escritura en papel.</p> |
|--|--|--|--|--|---|

## Specification

|                   |            |                          |       |                 |           |                 |         |                  |                         |                         |           |
|-------------------|------------|--------------------------|-------|-----------------|-----------|-----------------|---------|------------------|-------------------------|-------------------------|-----------|
| <b>Dimensions</b> | 7 x 137 mm | <b>Type of mechanism</b> | Twist | <b>Material</b> | Aluminium | <b>Finishes</b> | Lacquer | <b>Ink color</b> | Blue, Black (on demand) | <b>Packaging (pcs.)</b> | 50 / 1000 |
|-------------------|------------|--------------------------|-------|-----------------|-----------|-----------------|---------|------------------|-------------------------|-------------------------|-----------|

## Branding options

### Head

- Laser engraving Side B,C,D
- Pad printing Side B,C,D



### Barrel

- Laser engraving All Side
- Laser engraving 300° All Side
- Silkscreen printing 300° (Standard) All Side

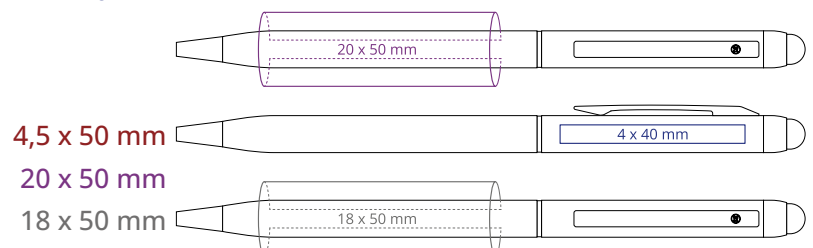

Product code: 404MG..

# TANTRA Soft Metal

Colors

Special  
production

check it out!



08

PMS 199



120

PMS 108



139

PMS 429



18

PMS 355



25

PMS 286



35

PMS Black

EN

Metal pen with rubbered surface, color coated barrel, with chrome coated details. Ink type: blue and black.

PL

Tantra długops metalowy, korpus softowany w kolorze, dodatki metalowe i chromowane, wkład niebieski lub czarny.

IT

Penna in metallo con superficie gommata, fusto colorato e dettagli cromati. Tipo di inchiostro: blu e nero.

FR

Stylo en métal avec surface caoutchoutée, corps revêtu de gommée avec coloré chromés. Type d'encre: bleue et noire.

DE

Tantra-Metall-Kugelschreiber, Soft, Chromzubehör, blaue oder schwarze Minen.

ES

Bolígrafo de metal con cuerpo en color y acabado soft y detalles cromados. Tipo de tinta: azul y negra.

Also available as an automatic pencil

## Specification

|            |             |                   |       |          |           |          |           |           |                         |                  |          |
|------------|-------------|-------------------|-------|----------|-----------|----------|-----------|-----------|-------------------------|------------------|----------|
| Dimensions | 11 x 145 mm | Type of mechanism | Click | Material | Aluminium | Finishes | SoftTouch | Ink color | Blue, Black (on demand) | Packaging (pcs.) | 40 / 800 |
|------------|-------------|-------------------|-------|----------|-----------|----------|-----------|-----------|-------------------------|------------------|----------|

## Branding options

### Clip

Laser engraving Side A

4,8 x 20 mm

### Barrel

Laser engraving All Side

6 x 60 mm / 6 x 85 mm

Laser engraving 300° All Side

34 x 60 mm

Pad printing Side B,D

5 x 45 mm

Silkscreen printing 300° (Standard) All Side

29 x 55 mm

Laser engraving 300° (Special) Side C

28 x 85 mm

Silkscreen printing 300° (Special) All Side

29 x 65 mm

ON DISASSEMBLED PEN

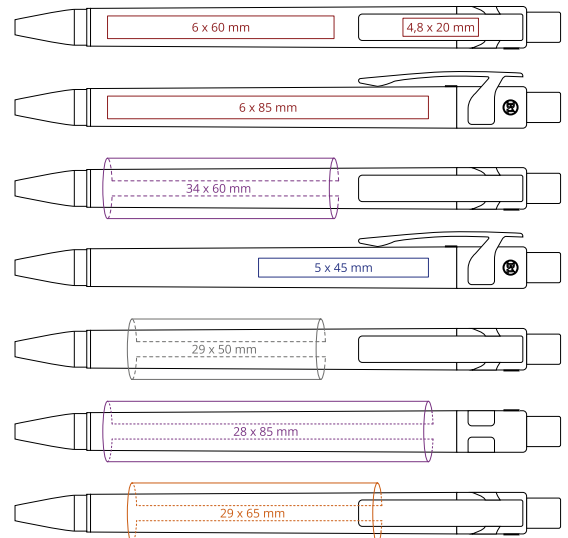

Product code: 404MTGUNG..

# TANTRA Soft Touch

Colors

Special production

check it out!



**08**  
PMS 199



**120**  
PMS 108



**139**  
PMS 429



**18**  
PMS 355



**25**  
PMS 286



**35**  
PMS Black

EN

Rubbered surface pen with color coated barrel, with graphite/gun coated details.

PL

Tantra Soft Touch długopis metalowy, korpus w kolorze, gumowana, softowa powierzchnia, dodatki grafit/gun, wkład niebieski lub czarny.

IT

Penna con superficie gommata e fusto colorato, con dettagli grafite/gun.

FR

Stylo à surface gommée avec corps coloré et détails graphite/gun.

DE

Tantra Soft Touch Metall-Kugelschreiber, Soft Oberfläche, Graphit/gun Zubehör, blaue oder schwarze Mine.

ES

Bolígrafo con cuerpo en color y acabado soft, con detalles color grafito.

Also available as an automatic pencil

## Specification

|            |             |                   |       |          |           |          |           |           |                         |                  |          |
|------------|-------------|-------------------|-------|----------|-----------|----------|-----------|-----------|-------------------------|------------------|----------|
| Dimensions | 11 x 145 mm | Type of mechanism | Click | Material | Aluminium | Finishes | SoftTouch | Ink color | Blue, Black (on demand) | Packaging (pcs.) | 40 / 800 |
|------------|-------------|-------------------|-------|----------|-----------|----------|-----------|-----------|-------------------------|------------------|----------|

## Branding options

### Clip

Laser engraving Side A

4,8 x 20 mm

### Barrel

Laser engraving Side All Side

6 x 6 mm / 6 x 85 mm

Laser engraving 300° All Side

34 x 60 mm

Pad printing Side B,C,D

5 x 45 mm

Silkscreen printing 300° (Standard) All Side

29 x 55 mm

Laser engraving 300° (Special) Side C

28 x 85 mm

Silkscreen printing 300° (Special) All Side

29 x 65 mm

ON DISASSEMBLED PEN

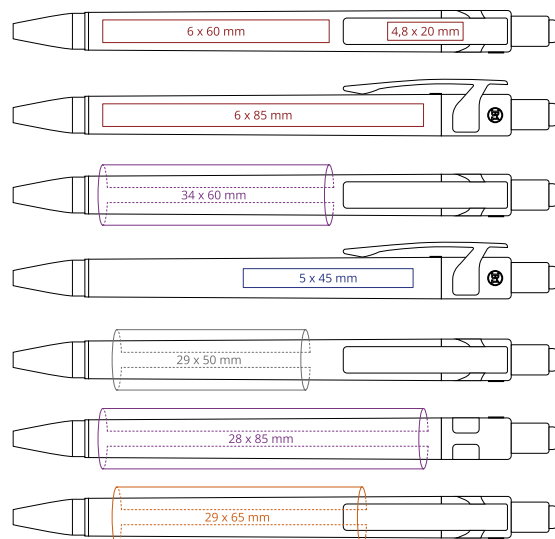



check it out!



# Case

EN

We offer a wide selection of cases designed for various purposes, ranging from single-function scratch-proof cases to more elaborate gift sets. **All cases may be individualized with designs.**

PL

Oferujemy szeroki wybór etui o różnym przeznaczeniu. Od pojedynczych spełniających funkcje zabezpieczające przed porysowaniem po eleganckie zestawy prezentowe. **Na wszystkich etui możliwe jest wykonanie znakowania.**

IT

Offriamo un'ampia selezione di custodie progettate per vari scopi, che vanno dalle custodie monofunzione antigraffio ai set regalo più elaborati. **Tutte le custodie possono essere personalizzate con disegni.**

FR

Nous proposons une large sélection d'étuis conçus pour différents usages, allant de l'étui anti-rayures à fonction unique à des coffrets cadeaux plus élaborés. **Tous les étuis peuvent être personnalisés avec des dessins.**

DE

Wir bieten eine breite Palette von Hüllen für verschiedene Zwecke. Vom einzelnen Etui zum Schutz vor Kratzern bis zum eleganten Geschenkset. **Alle Etuis können beschriftet werden.**

ES

Ofrecemos una amplia selección de fundas diseñadas para diversos fines, desde fundas de una sola función a prueba de arañazos hasta sets de regalo más elaborados. **Todos los estuches pueden individualizarse con diseños.**

Product code: 16409/35

## METAL Case



### Specification

|            |                  |          |       |          |               |        |       |                  |              |
|------------|------------------|----------|-------|----------|---------------|--------|-------|------------------|--------------|
| Dimensions | 165 x 68 x 33 mm | Material | Metal | Finishes | Lacquer satin | Weight | 170 g | Packaging (pcs.) | 1 / 50 / 100 |
|------------|------------------|----------|-------|----------|---------------|--------|-------|------------------|--------------|

### Branding options

|                                     |             |
|-------------------------------------|-------------|
| Laser engraving                     | 100 x 40 mm |
| Digital overprint                   | 100 x 40 mm |
| Pad printing                        | 50 x 15 mm  |
| Silkscreen printing 300° (Standard) | 130 x 30 mm |

Product code:

## SINGLE Case

#Novelties



### Specification

|            |                  |          |       |          |     |        |      |                  |              |
|------------|------------------|----------|-------|----------|-----|--------|------|------------------|--------------|
| Dimensions | 162 x 30 x 28 mm | Material | Paper | Finishes | Mat | Weight | 20 g | Packaging (pcs.) | 1 / 50 / 100 |
|------------|------------------|----------|-------|----------|-----|--------|------|------------------|--------------|

### Branding options

|                                     |             |
|-------------------------------------|-------------|
| Silkscreen printing 300° (Standard) | 22 x 150 mm |
|-------------------------------------|-------------|



table of contents

# PAPER Packaging



**SLIP CASE**  
Black



**SLIP CASE**  
White



**PILLOWBOX**  
Black



**PILLOW BOX**  
White

Product code: 987/35

## PAPER Case



### Specification

|                   |                  |                 |       |                 |     |               |      |                         |          |
|-------------------|------------------|-----------------|-------|-----------------|-----|---------------|------|-------------------------|----------|
| <b>Dimensions</b> | 166 x 38 x 20 mm | <b>Material</b> | Paper | <b>Finishes</b> | Mat | <b>Weight</b> | 13 g | <b>Packaging (pcs.)</b> | 20 / 100 |
|-------------------|------------------|-----------------|-------|-----------------|-----|---------------|------|-------------------------|----------|

### Branding options

Silkscreen printing 300° (Standard)

145 x 28 mm

Product code: 988/47

## PAPER Sleeve



### Specification

|                   |             |                 |       |                 |       |               |       |                         |      |
|-------------------|-------------|-----------------|-------|-----------------|-------|---------------|-------|-------------------------|------|
| <b>Dimensions</b> | 150 x 40 mm | <b>Material</b> | Paper | <b>Finishes</b> | Paper | <b>Weight</b> | 3,9 g | <b>Packaging (pcs.)</b> | 2100 |
|-------------------|-------------|-----------------|-------|-----------------|-------|---------------|-------|-------------------------|------|

Product code: 19606/90

## CYLINDRICAL Case



### Specification

|                   |                |                 |         |                 |         |               |      |                         |              |
|-------------------|----------------|-----------------|---------|-----------------|---------|---------------|------|-------------------------|--------------|
| <b>Dimensions</b> | 151 x fi 14 mm | <b>Material</b> | Plastic | <b>Finishes</b> | Plastic | <b>Weight</b> | 17 g | <b>Packaging (pcs.)</b> | 1 / 50 / 100 |
|-------------------|----------------|-----------------|---------|-----------------|---------|---------------|------|-------------------------|--------------|

### Branding options

Digital overprint

115 x 8 / 12 x 12 mm

Discover the best **BI Pen** sell-out options!





Create brand connections to excellence with  
personalized notebooks that foster sustainable  
personal spaces in a digital society

# LADY GRS

#recycled PU cover

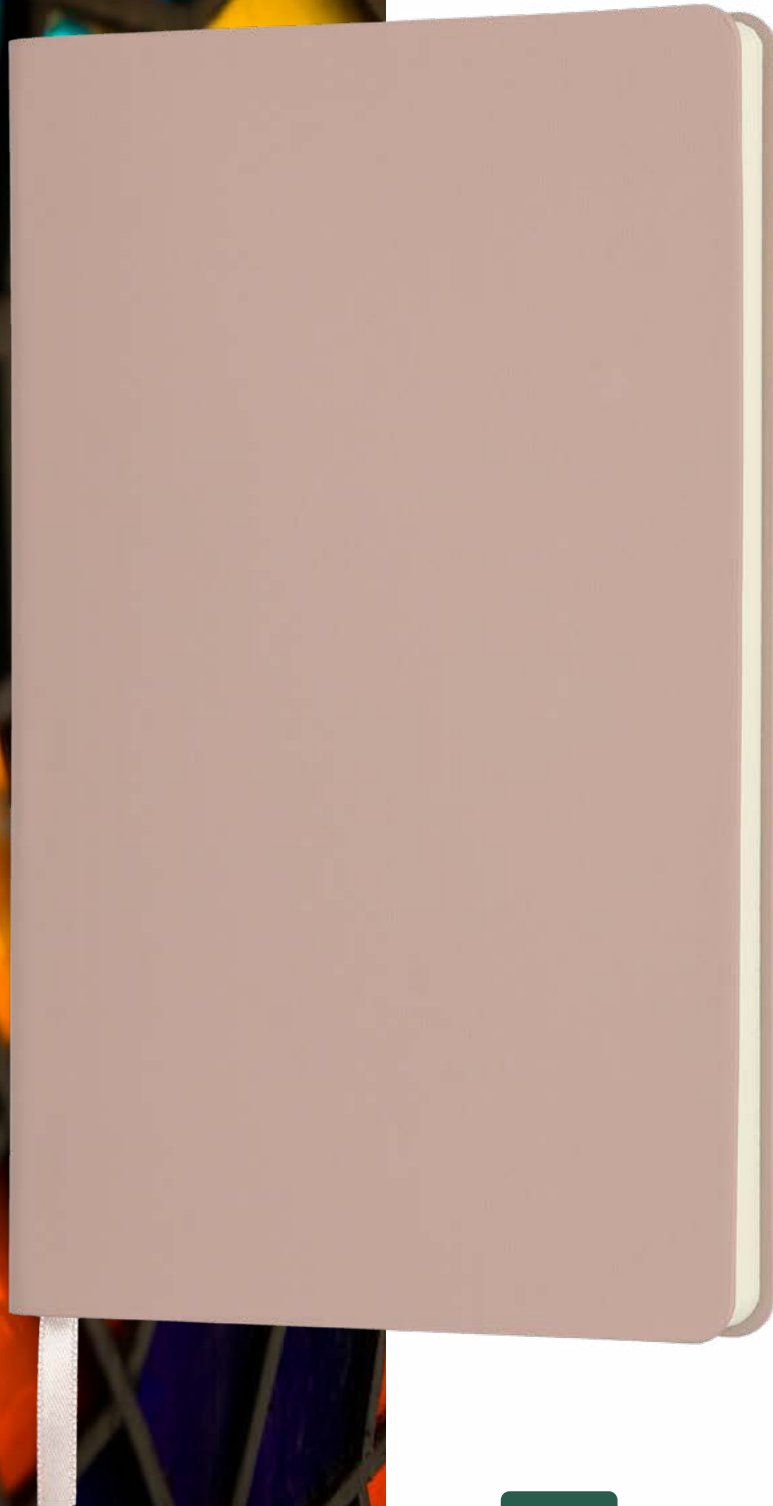

The mark of  
responsible forestry  
FSC® C118860

New

table of contents

Product code: TM21251/R..

# LADY GRS



check it out!

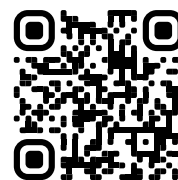

## Colors



02 PMS 4239    04 PMS 602    08 PMS 201    09 PMS 7633    15 PMS 7731    26 PMS 4152    30 PMS WARM GREY 5    35 PMS BLACK

## Paper pattern

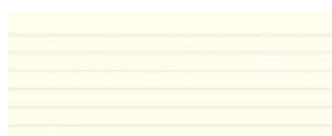

Lines

|   |  |   |  |  |   |
|---|--|---|--|--|---|
| <p><b>EN</b></p> <p>A stylish and practical notebook with a flexible cover made of an exceptionally pleasant-to-touch material derived from <b>recycled PET plastic packaging</b>. A ribbon matching the color of the cover adds practicality. The notebook features a <b>lined block</b>. An ideal choice for those who value sustainability and elegant design.</p> | <p><b>PL</b></p> <p>Stylowy i praktyczny notes o elastycznej okładce wykonanej z wyjątkowo przyjemnego w dotyku materiału pochodzącego z <b>recyklingu opakowań plastikowych PET</b>. Wstążka w kolorze dopasowanym do okładki. Notes wyposażony jest w <b>blok w linie</b>. Idealny wybór dla osób ceniących równowagę rozwój i elegancki design.</p> | <p><b>IT</b></p> <p>Un taccuino elegante e pratico con una copertina flessibile realizzata in un materiale straordinariamente piacevole al tatto, derivato dal riciclo di imballaggi in <b>plastica PET</b>. Un nastro abbinato al colore della copertina aggiunge praticità. Il taccuino è dotato di pagine a righe. Una scelta ideale per chi apprezza la sostenibilità e il design elegante.</p> | <p><b>FR</b></p> <p>Un carnet élégant et pratique avec une couverture souple fabriquée dans un matériau exceptionnellement agréable au toucher, issu du recyclage d'emballages en <b>plastique PET</b>. Un ruban assorti à la couleur de la couverture ajoute à sa praticité. Le carnet est équipé de pages lignées. Un choix idéal pour ceux qui valorisent la durabilité et le design élégant.</p> | <p><b>DE</b></p> <p>Ein stilvolles und praktisches Notizbuch mit einem flexiblen Einband aus einem besonders angenehm anzufassenden Material, das aus <b>recyclten PET-Kunststoffverpackungen</b> hergestellt wurde. Ein farblich abgestimmtes Lesezeichenband. Das Notizbuch ist mit einem <b>linierten Block</b> ausgestattet. Die perfekte Wahl für alle, die Nachhaltigkeit und elegantes Design schätzen.</p> | <p><b>ES</b></p> <p>Un cuaderno elegante y práctico con una cubierta flexible hecha de un material excepcionalmente agradable al tacto, derivado del reciclaje de envases de <b>plástico PET</b>. Una cinta a juego con el color de la cubierta añade funcionalidad. El cuaderno incluye páginas rayadas. Una elección ideal para quienes valoran la sostenibilidad y el diseño elegante.</p> |
|---|--|---|--|--|---|

## Specification

|                       |              |                       |          |                       |              |                   |          |                         |         |
|-----------------------|--------------|-----------------------|----------|-----------------------|--------------|-------------------|----------|-------------------------|---------|
| <b>Dimensions</b>     | 130 x 210 mm | <b>Pages / sheets</b> | 192 / 96 | <b>Cover material</b> | GRS Recycled | <b>Cover type</b> | Flexible | <b>Packaging (pcs.)</b> | 25 / 50 |
| <b>Pages material</b> | Paper FSC®   | <b>Paper color</b>    | Chamois  | <b>Paper density</b>  | 70g          | <b>Extras</b>     | X        |                         |         |

## Branding options

### Front cover

|  |              |
|--|--------------|
| Digital overprint                      | 100 x 180 mm |
| Silkscreen printing                    | 100 x 180 mm |
| Embossing                              | 100 x 180 mm |
| Foil stamping ( <i>metallic foil</i> ) | 100 x 180 mm |

### Back cover

|  |              |
|--|--------------|
| Digital overprint                      | 100 x 150 mm |
| Silkscreen printing                    | 100 x 150 mm |
| Embossing                              | 100 x 150 mm |
| Foil stamping ( <i>metallic foil</i> ) | 100 x 150 mm |

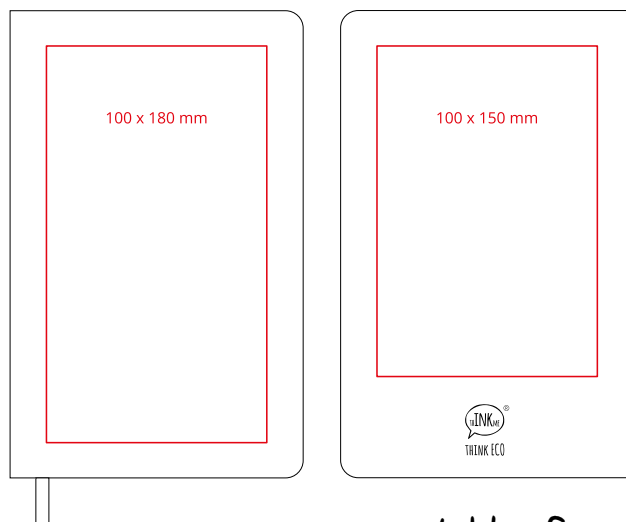

table of contents

# SHADY GRS

#recycled PU cover



The mark of  
responsible forestry  
FSC® C118860

table of contents

Product code: TM21250R/..

# SHADY GRS

check it out!



## Colors

**08**  
PMS 200

**24**  
PMS 3506

**26**  
PMS 534

**30**  
PMS 423

**35**  
PMS Black

## Paper pattern

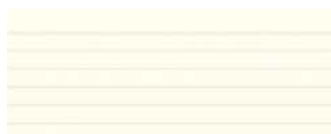

Lines



Squaer



Dots

**EN**

Notebook in **soft, elastic cover**, with vertical elastic band and ribbon. The edges of the block in the color of the cover. **GRS notebook cover** is made of **recycled materials** containing polyester from used plastic bottles.

**PL**

Notes w **miękkiej, elastycznej okładce**, z pionową gumką i wstążką. Brzegi bloku w kolorze okładki. Okładka **notesu GRS** jest wykonana z **materiałów pochodzących z recyklingu**, zawierających poliester ze zużytych plastikowych butelek.

**IT**

Quaderno in **morbida copertina elastica**, con elastico verticale e nastro. I bordi del blocco sono del colore della copertina. La copertina del **quaderno GRS** è realizzata con **materiali riciclati contenenti poliestere** proveniente da bottiglie di plastica usate.

**FR**

Cahier à **couverture souple et élastique**, avec élastique vertical et ruban. Les bords du bloc sont de la même couleur que la couverture. La couverture du **carnet GRS** est fabriquée à partir de **matériaux recyclés contenant** du polyester provenant de bouteilles en plastique usagées.

**DE**

Notizbuch mit **weichem, elastischem Einband**, mit vertikalem Gummiband und Band. Die Kanten des Blocks in der Farbe des Covers. Die **GRS-Notizbuchhülle** besteht aus **recyclten Materialien**, die Polyester aus gebrauchten Plastikflaschen enthalten.

**ES**

Cuaderno de **tapas blandas y elásticas**, con banda elástica vertical y cinta. Los bordes del bloque en el color de la cubierta. La cubierta del **cuaderno GRS** está fabricada con materiales reciclados que **contienen poliéster** procedente de botellas de plástico usadas.

## Specification

|                       |              |                       |           |                       |              |                   |   |                         |         |
|-----------------------|--------------|-----------------------|-----------|-----------------------|--------------|-------------------|---|-------------------------|---------|
| <b>Dimensions</b>     | 140 x 200 mm | <b>Pages / sheets</b> | 272 / 136 | <b>Cover material</b> | GRS Recycled | <b>Cover type</b> | Flexible  | <b>Packaging (pcs.)</b> | 20 / 40 |
| <b>Pages material</b> | Paper FSC®   | <b>Paper color</b>    | Chamois   | <b>Paper density</b>  | 70g          | <b>Extras</b>     | Elastic band, same color as cover - vertical, Ribbon, same color as cover |                         |         |

## Branding options

### Front cover

|  |              |
|--|--------------|
| Digital overprint                      | 100 x 173 mm |
| Silkscreen printing                    | 100 x 173 mm |
| Embossing                              | 100 x 173 mm |
| Foil stamping ( <i>metallic foil</i> ) | 100 x 173 mm |

### Back cover

|  |             |
|--|-------------|
| Digital overprint                      | 90 x 145 mm |
| Silkscreen printing                    | 80 x 100 mm |
| Embossing                              | 90 x 145 mm |
| Foil stamping ( <i>metallic foil</i> ) | 90 x 145 mm |

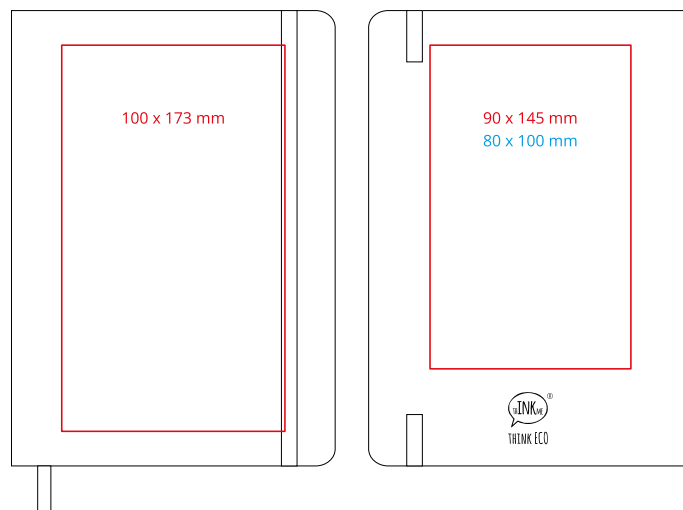

table of contents



# GRACY GRS

#recycled PU cover



The mark of  
responsible forestry  
FSC® C118860

Product code: TM21223/R..

# GRACY GRS

Check it out



## Colors

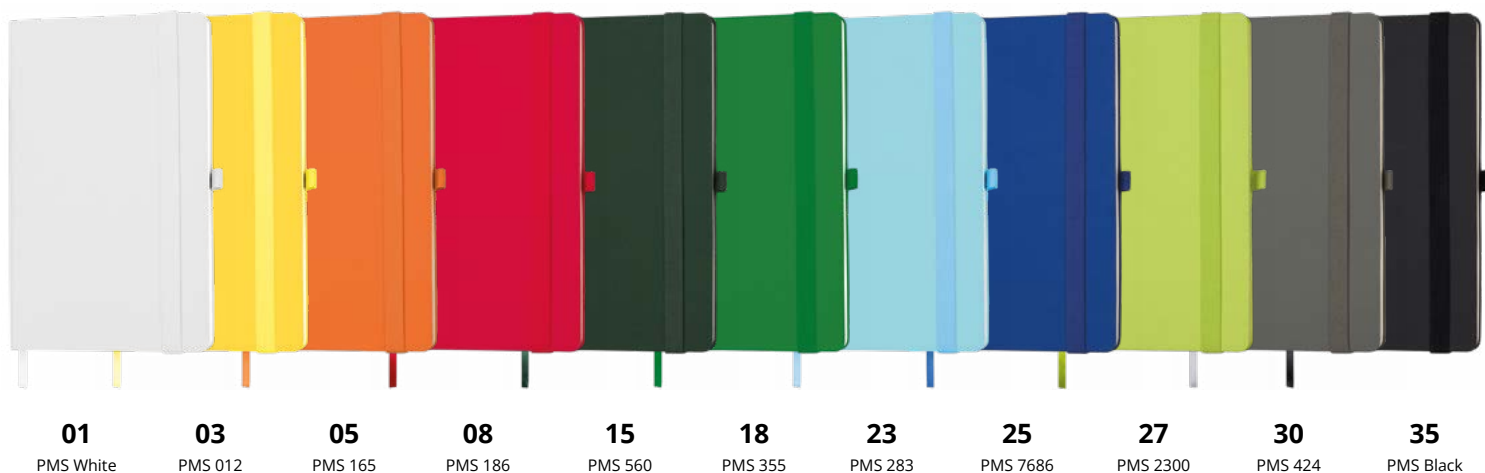

## Paper pattern

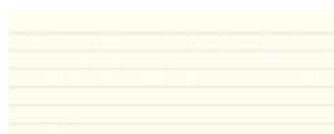

Lines

**EN**

A soft-touch cover juxtaposed with chic accessories and intense colours. Subtle and expressive in one, the **GRS notebook** cover is made from **recycled materials** containing polyester from used plastic bottles. The equivalent of the **GRACY notebook**.

**PL**

Delikatna w dotyku okładka w zestawieniu z szykownymi dodatkami oraz intensywnymi kolorami. Subtelny i wyrazisty w jednym. Okładka **notesu GRS** jest wykonana z materiałów **pochozących z recyklingu**, zawierających poliester ze zużytych plastikowych butelek. **Odpowiednik notesu GRACY.**

**IT**

Una copertina morbida al tatto accostata ad accessori chic e a colori intensi. Sottile ed espressiva in un'unica soluzione, la copertina del taccuino **GRS è realizzata con materiali riciclati** contenenti poliesterre provenienti da bottiglie di plastica usate.

**FR**

Une couverture douce au toucher juxtaposée à des accessoires chics et des couleurs intenses. Subtil et expressif à la fois, le **protège-cahier GRS** est fabriqué à partir de **matériaux recyclés** contenant du polyester issu de bouteilles en plastique usagées.

**DE**

Ein weicher Einband, der mit schicken Accessoires und intensiven Farben kombiniert wird. Das dezente und ausdrucksstarke Cover des **GRS-Notizbuchs** besteht aus **recyclten Materialien**, die Polyester aus gebrauchten Plastikflaschen enthalten - das **Pendant zum GRACY-Notizbuch.**

**ES**

Una cubierta suave al tacto yuxtapuesta con accesorios chic y colores intensos. Sutil y expresiva a la vez, la cubierta del **cuaderno GRS** está fabricada con **materiales reciclados** que contienen poliéster procedente de botellas de plástico usadas.

## Specification

|                       |              |                       |          |                       |              |                   |   |                         |         |
|-----------------------|--------------|-----------------------|----------|-----------------------|--------------|-------------------|---|-------------------------|---------|
| <b>Dimensions</b>     | 130 x 210 mm | <b>Pages / sheets</b> | 192 / 96 | <b>Cover material</b> | GRS Recycled | <b>Cover type</b> | Flexible  | <b>Packaging (pcs.)</b> | 25 / 50 |
| <b>Pages material</b> | Paper FSC®   | <b>Paper color</b>    | Chamois  | <b>Paper density</b>  | 70g          | <b>Extras</b>     | Perforated sheets - 8, Pen holder, Elastic band |                         |         |

## Branding options

### Front cover

|  |              |
|--|--------------|
| Digital overprint                      | 100 x 180 mm |
| Silkscreen printing                    | 100 x 180 mm |
| Embossing                              | 100 x 180 mm |
| Foil stamping ( <i>metallic foil</i> ) | 100 x 180 mm |

### Back cover

|  |                        |
|--|------------------------|
| Silkscreen printing                    | 70 x 150 / 90 x 105 mm |
| Embossing                              | 70 x 150 / 90 x 105 mm |
| Foil stamping ( <i>metallic foil</i> ) | 70 x 150 / 90 x 105 mm |

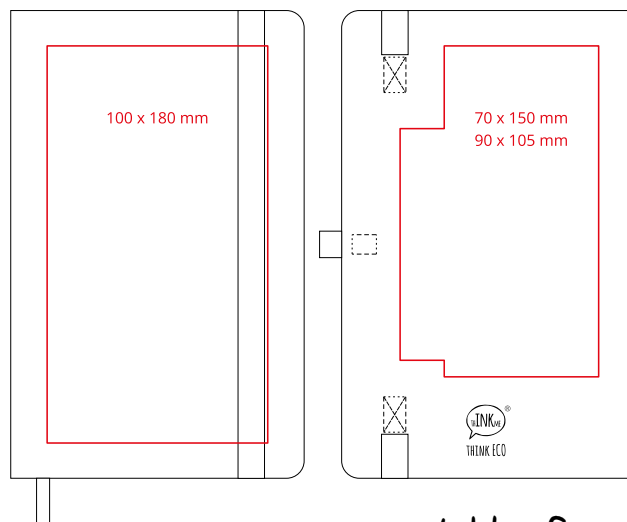

table of contents

# FUNKY GRS

#recycled PU cover



The mark of  
responsible forestry  
FSC® C118860

table of contents

Product code: TM21209/R..

# FUNKY GRS

Check it out



## Colors



|                         |                         |                         |                     |                          |                          |                          |                          |                         |                         |                           |
|-------------------------|-------------------------|-------------------------|---------------------|--------------------------|--------------------------|--------------------------|--------------------------|-------------------------|-------------------------|---------------------------|
| <b>03/30</b><br>PMS 107 | <b>06/30</b><br>PMS 158 | <b>08/30</b><br>PMS 200 | <b>10/30</b><br>PMS | <b>11/30</b><br>PMS 7447 | <b>15/30</b><br>PMS 3435 | <b>22/30</b><br>PMS 7688 | <b>24/30</b><br>PMS 2386 | <b>26/30</b><br>PMS 534 | <b>30/30</b><br>PMS 423 | <b>35/30</b><br>PMS Black |
|-------------------------|-------------------------|-------------------------|---------------------|--------------------------|--------------------------|--------------------------|--------------------------|-------------------------|-------------------------|---------------------------|

## Paper pattern

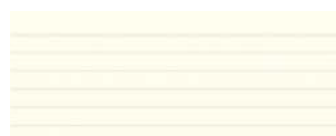

Lines

grey  
endpapers!



|   |  |   |  |   |  |
|---|--|---|--|---|--|
| <b>EN</b>   | <b>PL</b>  | <b>IT</b>   | <b>FR</b>  | <b>DE</b>   | <b>ES</b>  |
| An attractive model with a rich colour palette to choose from. Delightful with its mix of colours and flexible cover. The cover of the <b>GRS notebook</b> is made from <b>recycled materials</b> containing polyester from used plastic bottles. <b>The counterpart to the FUNKY notebook.</b> | Atrakcyjny model z bogatą paletą barw do wyboru. Zachwycający mixem kolorów i elastyczną okładką. Okładka <b>notesu GRS</b> jest wykonana z <b>materiałów pochodzących z recyklingu</b> , zawierających poliester ze zużytych plastikowych butelek. <b>Odpowiednik notesu FUNKY.</b> | Un modello attraente con una ricca gamma di colori tra cui scegliere. Delizioso grazie al mix di colori e alla copertina flessibile. La copertina del taccuino <b>GRS</b> è realizzata con <b>materiali riciclati</b> che contengono poliestere proveniente da bottiglie di plastica usate. | Un modèle attrayant avec une riche palette de couleurs. Il séduit par son mélange de couleurs et sa couverture souple. La couverture du <b>carnet GRS</b> est fabriquée à partir de <b>matériaux recyclés</b> contenant du polyester provenant de bouteilles en plastique usagées. | Ein attraktives Modell mit einer reichen Farbpalette zur Auswahl. Es besticht durch seinen Farbmix und den flexiblen Einband. Der Einband des <b>GRS-Notizbuchs</b> besteht aus <b>recycelten Materialien</b> , die Polyester aus gebrauchten Plastikflaschen enthalten - das Gegenstück zum FUNKY-Notizbuch. | Un modelo atractivo con una rica paleta de colores para elegir. Encantador por su mezcla de colores y su tapa flexible. La cubierta del <b>cuaderno GRS</b> está fabricada con <b>materiales reciclados</b> que contienen políester procedente de botellas de plástico usadas. |

## Specification

|                       |              |                       |           |                       |              |                   |                  |                         |         |
|-----------------------|--------------|-----------------------|-----------|-----------------------|--------------|-------------------|------------------|-------------------------|---------|
| <b>Dimensions</b>     | 130 x 210 mm | <b>Pages / sheets</b> | 256 / 128 | <b>Cover material</b> | GRS Recycled | <b>Cover type</b> | Flexible         | <b>Packaging (pcs.)</b> | 20 / 40 |
| <b>Pages material</b> | Paper FSC®   | <b>Paper color</b>    | Chamois   | <b>Paper density</b>  | 70g          | <b>Extras</b>     | Information page |                         |         |

## Branding options

### Front cover

|  |              |
|--|--------------|
| Digital overprint                      | 100 x 180 mm |
| Silkscreen printing                    | 100 x 180 mm |
| Embossing                              | 100 x 180 mm |
| Foil stamping ( <i>metallic foil</i> ) | 100 x 180 mm |

### Back cover

|  |              |
|--|--------------|
| Digital overprint                      | 100 x 150 mm |
| Silkscreen printing                    | 100 x 150 mm |
| Embossing                              | 100 x 150 mm |
| Foil stamping ( <i>metallic foil</i> ) | 100 x 150 mm |

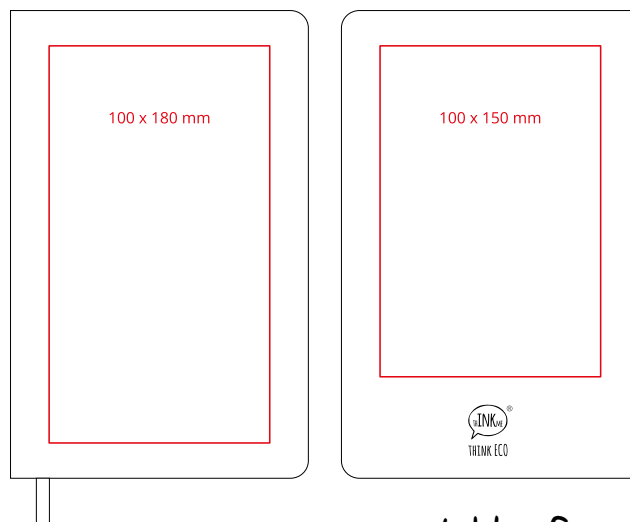
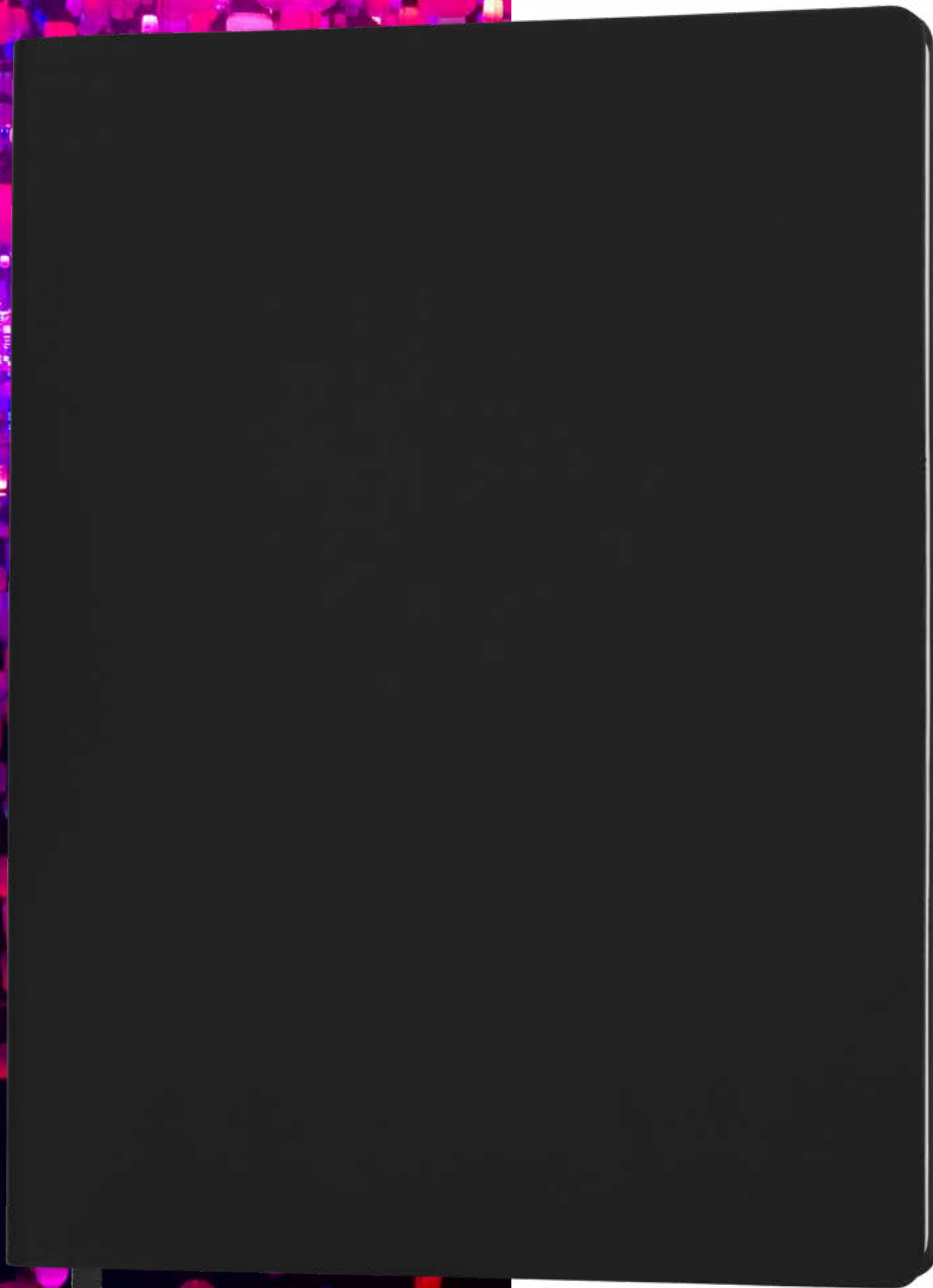

table of contents

# BIGGY GRS

#recycled PU cover



The mark of  
responsible forestry  
FSC® C118860

table of contents

Product code: TM21218R/..

# BIGGY GRS

Check it out



## Colors

**08**

PMS 200

**25**

PMS 7686



**30**

PMS 418

**35**

PMS Black

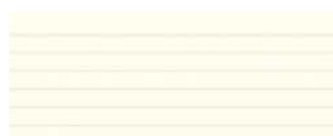
## Paper pattern



Lines



Squar

**EN**

The large format allows for more, and the soft-touch elastic cover of the **GRS notebook** is made from recycled materials containing polyester from used plastic bottles. **The equivalent of the BIGGY notebook.**

**PL**

Duży format pozwala na więcej, a delikatna w dotyku softowa okładka **notesu GRS** jest wykonana z materiałów pochodzących z recyklingu, zawierających poliester ze zużytych plastikowych butelek. **Odpowiednik notesu BIGGY.**

**IT**

Il grande formato permette di avere più spazio e la copertina morbida al tatto del **taccuino GRS** è realizzata con materiali riciclati contenenti poliester proveniente da bottiglie di plastica usate. **L'equivalente del taccuino BIGGY.**

**FR**

Le grand format permet d'en faire plus, et la couverture douce au toucher du **carnet GRS** est fabriquée à partir de matériaux recyclés contenant du polyester provenant de bouteilles en plastique usagées.

**DE**

Das große Format lässt mehr zu, und der Soft-Touch-Einband des **GRS-Notizbuchs** besteht aus recycelten Materialien, die Polyester aus gebrauchten Plastikflaschen enthalten - das **Pendant zum BIGGY-Notizbuch.**

**ES**

El gran formato permite mucho más, y la cubierta blanda y suave al tacto del **cuaderno GRS** está fabricada con materiales reciclados que contienen poliéster procedente de botellas de plástico usadas. **El equivalente al cuaderno BIGGY.**

## Specification

|                       |              |                       |           |                       |              |                   |  |                         |         |
|-----------------------|--------------|-----------------------|-----------|-----------------------|--------------|-------------------|--|-------------------------|---------|
| <b>Dimensions</b>     | 190 x 250 mm | <b>Pages / sheets</b> | 256 / 128 | <b>Cover material</b> | GRS Recycled | <b>Cover type</b> | Flexible                               | <b>Packaging (pcs.)</b> | 10 / 20 |
| <b>Pages material</b> | Paper FSC®   | <b>Paper color</b>    | Chamois   | <b>Paper density</b>  | 70g          | <b>Extras</b>     | Perforated sheets - 8, ribbon bookmark |                         |         |

## Branding options

### Front cover

|  |              |
|--|--------------|
| Digital overprint                      | 160 x 220 mm |
| Silkscreen printing                    | 160 x 220 mm |
| Embossing                              | 160 x 220 mm |
| Foil stamping ( <i>metallic foil</i> ) | 160 x 220 mm |

### Back cover

|  |              |
|--|--------------|
| Digital overprint                      | 160 x 190 mm |
| Silkscreen printing                    | 160 x 190 mm |
| Embossing                              | 160 x 190 mm |
| Foil stamping ( <i>metallic foil</i> ) | 160 x 190 mm |

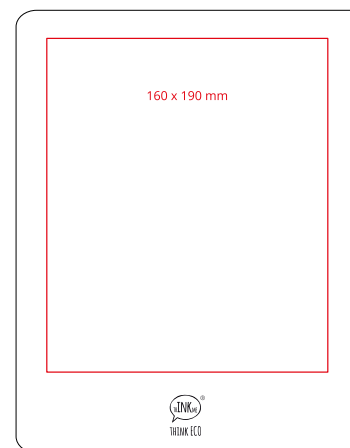
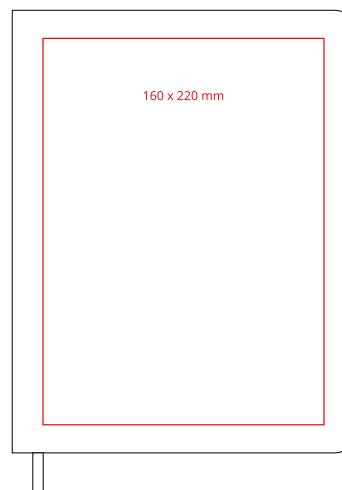
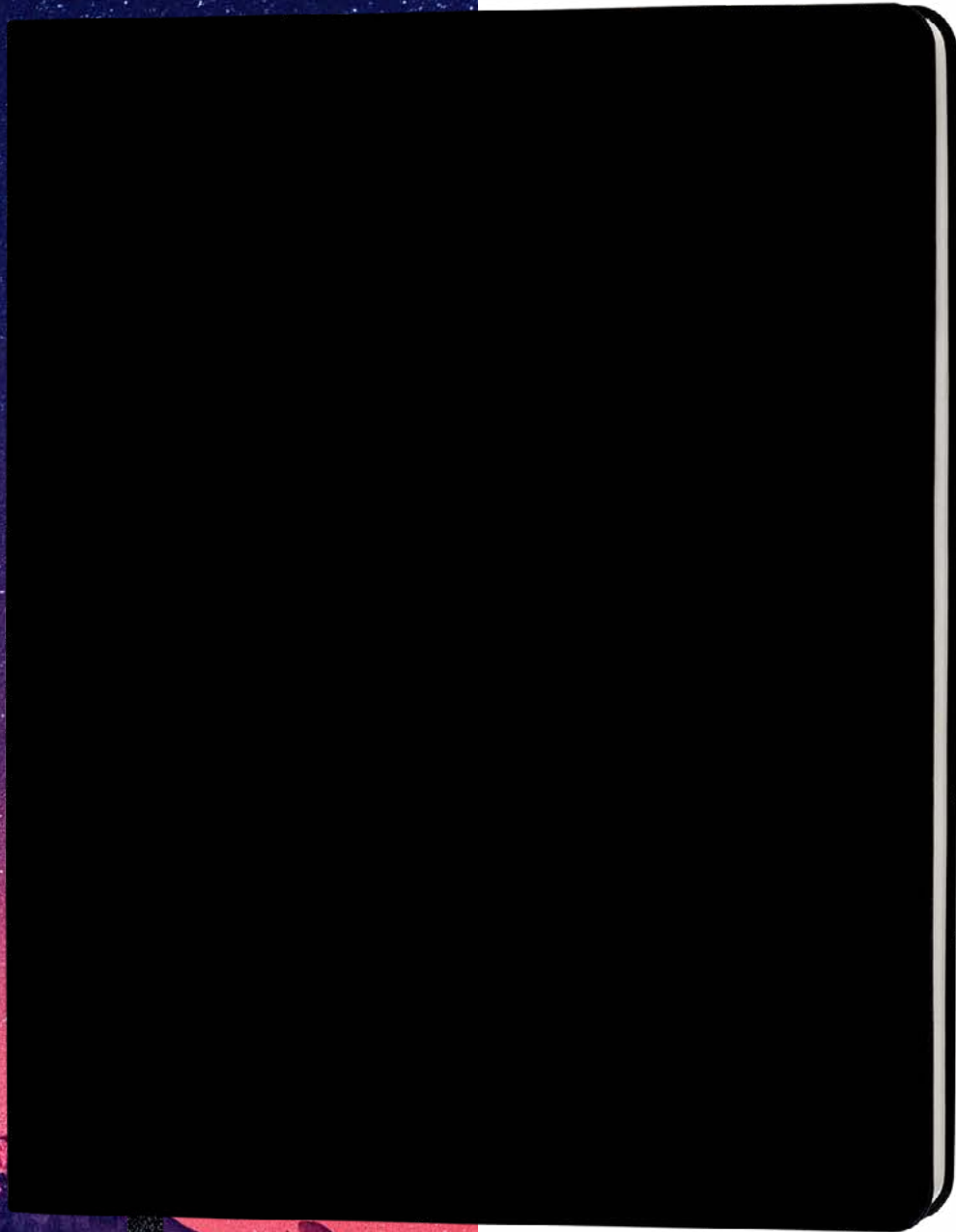

table of contents

# CUBI GRS XL

#recycled PU cover



The mark of  
responsible forestry  
FSC® C118860

table of contents

Product code: TM21231/R..XL

# CUBI GRS XL *New*

check it out!

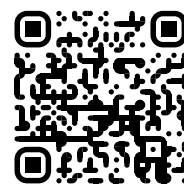

## Colors



**08**  
PMS 186



**25**  
PMS 7686



**30**  
PMS 2332



**35**  
PMS Black

## Paper pattern

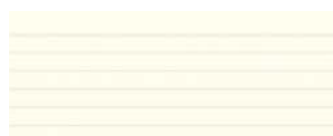

Lines

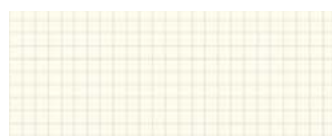

Squaer

**EN**

A square notebook with a flexible, soft-to-the-touch cover. The GRS notebook cover is made from **recycled materials**, including polyester derived from used plastic bottles.

**PL**

Kwadratowy notes z elastyczną, miękką w dotyku okładką. Okładka notesu GRS wykonana jest z materiałów **pocho-dzących z recyklingu**, w tym z poliestru uzyskanego z uży-wanych butelek plastikowych.

**IT**

Un quaderno quadrato con una copertina flessibile e morbida al tatto. La copertina del quaderno GRS è realizzata con **materiali riciclati**, incluso il poliestere derivato da bottiglie di plastica usate.

**FR**

Un carnet carré avec une couverture flexible et douce au toucher. La couverture du carnet GRS est fabriquée à partir de **matériaux recyclés**, notamment du polyester issu de bouteilles en plastique usagées.

**DE**

Quadratisches Notizbuch mit einer flexiblen, angenehm weichen Hülle. Der Umschlag des GRS-Notizbuchs besteht aus **recyclelten Materialien**, darunter Polyester aus gebrauchten Plastikflaschen.

**ES**

Un cuaderno cuadrado con una cubierta flexible y suave al tacto. La cubierta del cuaderno GRS está hecha de **materiales reciclados**, incluido poliéster derivado de botellas de plástico usadas.

## Specification

|                       |              |                       |           |                       |              |                   |                       |                         |         |
|-----------------------|--------------|-----------------------|-----------|-----------------------|--------------|-------------------|-----------------------|-------------------------|---------|
| <b>Dimensions</b>     | 210 x 210 mm | <b>Pages / sheets</b> | 256 / 128 | <b>Cover material</b> | GRS Recycled | <b>Cover type</b> | Flexible              | <b>Packaging (pcs.)</b> | 20 / 40 |
| <b>Pages material</b> | Paper FSC®   | <b>Paper color</b>    | Chamois   | <b>Paper density</b>  | 70g          | <b>Extras</b>     | Perforated sheets - 8 |                         |         |

## Branding options

### Front cover

|  |              |
|--|--------------|
| Digital overprint                      | 180 x 180 mm |
| Silkscreen printing                    | 180 x 180 mm |
| Embossing                              | 180 x 180 mm |
| Foil stamping ( <i>metallic foil</i> ) | 180 x 180 mm |

### Back cover

|  |              |
|--|--------------|
| Digital overprint                      | 150 x 180 mm |
| Silkscreen printing                    | 150 x 180 mm |
| Embossing                              | 150 x 180 mm |
| Foil stamping ( <i>metallic foil</i> ) | 150 x 180 mm |





# CUBI GRS

#recycled PU cover

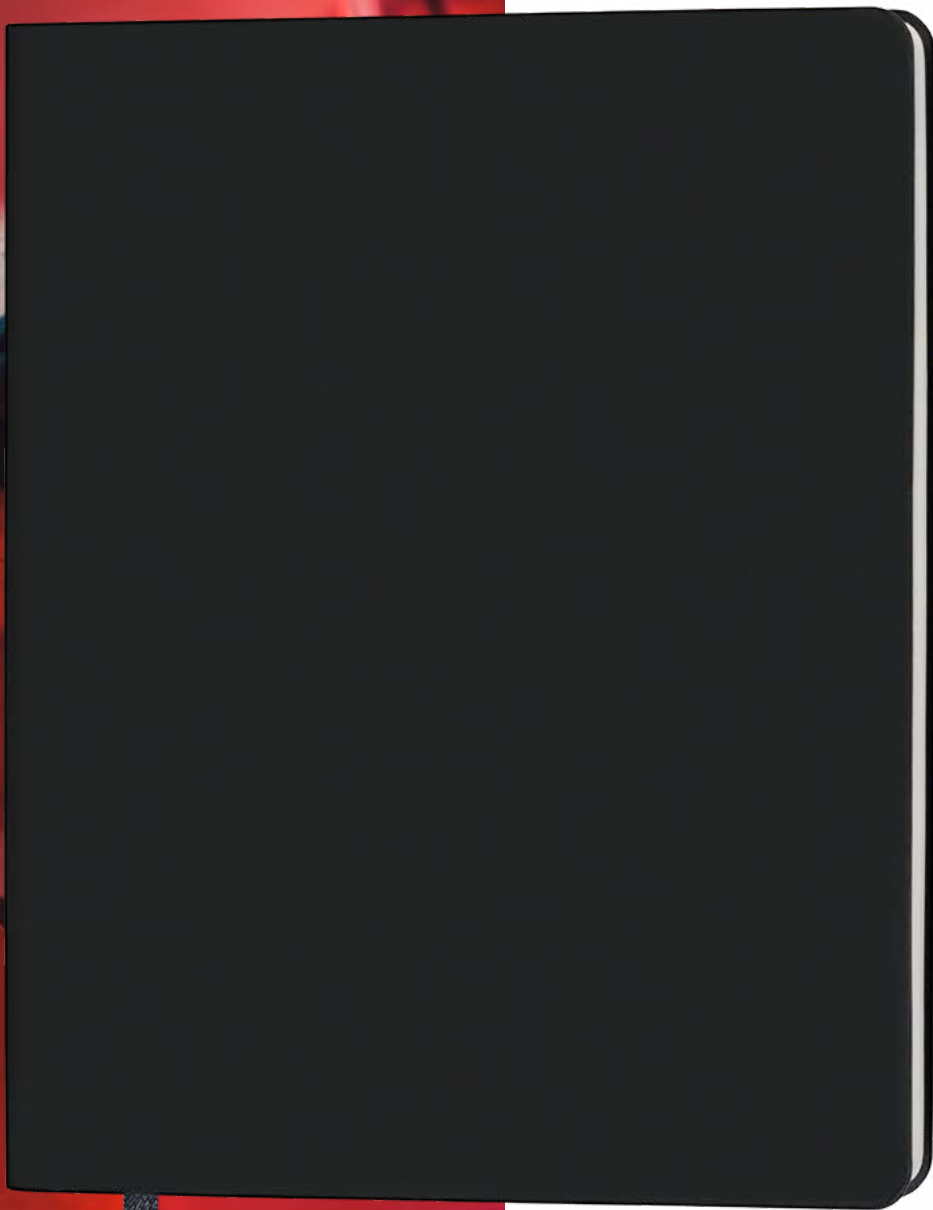

The mark of  
responsible forestry  
FSC® C118860

table of contents

Product code: TM21221/R..

# CUBI GRS

Check it out



## GRS Colors



08

PMS 186



25

PMS 7686



30

PMS 2332



35

PMS Black

## Paper pattern

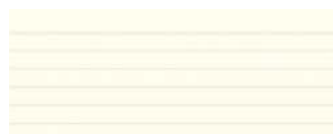

Lines



Squaer

EN

A custom square and soft touch cover juxtaposed with chic accessories and muted colours. Subtle and distinctive in one, the **GRS notebook** cover is made from **recycled materials** containing polyester from used plastic bottles. **The counterpart to the CUBI notebook.**

PL

Niestandardowa kwadratowa i delikatna w dotyku okładka w zestawieniu z szykownymi dodatkami oraz stonowanymi kolorami. Subtelny i wyrazisty w jednym. Okładka **notesu GRS** jest wykonana z **materiałów pochodzących z recyklingu, zawierających poliester** ze zużytych plastikowych butelek. **Odpowiednik notesu CUBI.**

IT

Una copertina personalizzata, quadrata e morbida al tatto, accostata ad accessori chic e a colori tenui. Sottile e distintiva allo stesso tempo, la copertina del **taccuino GRS** è realizzata con **materiali riciclati** contenenti poliestere proveniente da bottiglie di plastica usate. **La controparte del taccuino CUBI.**

FR

Une couverture personnalisée, carrée et douce au toucher, juxtaposée à des accessoires chics et à des couleurs sourdes. Subtile et distinctive à la fois, la couverture du **carnet GRS** est fabriquée à partir de **matériaux recyclés** contenant du polyester provenant de bouteilles en plastique usagées. **Le pendant du carnet CUBI.**

DE

Ein individuelles, quadratisches Cover mit weichem Griff, das mit schicken Accessoires und gedeckten Farben kombiniert wird. **Das GRS-Notizbuchcover** ist subtil und ausdrucksstark zugleich und wird aus **recycelten Materialien** hergestellt, die Polyester aus gebrauchten Plastikflaschen enthalten - das Gegenstück zum CUBI-Notizbuch.

ES

Una cubierta cuadrada personalizada y de tacto suave yuxtapuesta con accesorios chic y colores apagados. Sutil y distintiva a la vez, la tapa del **cuaderno GRS** está fabricada con **materiales reciclados** que contienen poliéster procedente de botellas de plástico usadas. **La contrapartida del cuaderno CUBI.**

## Specification

|                |              |                |           |                |              |            |                        |                  |         |
|----------------|--------------|----------------|-----------|----------------|--------------|------------|------------------------|------------------|---------|
| Dimensions     | 150 x 180 mm | Pages / sheets | 256 / 128 | Cover material | GRS Recycled | Cover type | Flexible               | Packaging (pcs.) | 20 / 40 |
| Pages material | Paper FSC®   | Paper color    | Chamois   | Paper density  | 70g          | Extras     | Perforated sheets - 8, |                  |         |

## Branding options

### Front cover

|  |              |
|--|--------------|
| Digital overprint                      | 120 x 150 mm |
| Silkscreen printing                    | 120 x 150 mm |
| Embossing                              | 120 x 150 mm |
| Foil stamping ( <i>metallic foil</i> ) | 120 x 150 mm |

### Back cover

|  |              |
|--|--------------|
| Digital overprint                      | 120 x 135 mm |
| Silkscreen printing                    | 120 x 135 mm |
| Embossing                              | 120 x 135 mm |
| Foil stamping ( <i>metallic foil</i> ) | 120 x 135 mm |

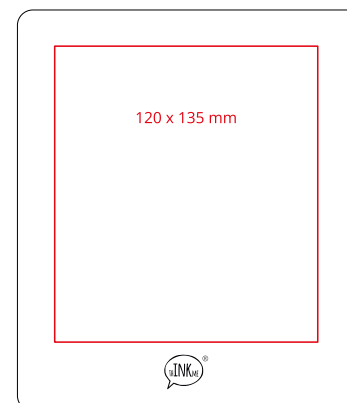
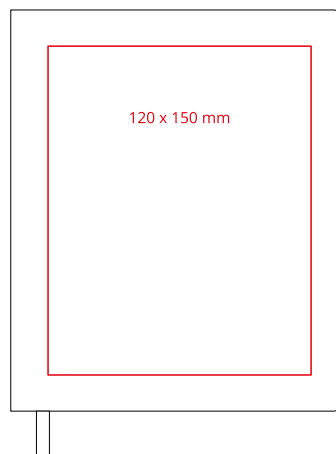

# AUDREY GRS

#recycled PU cover

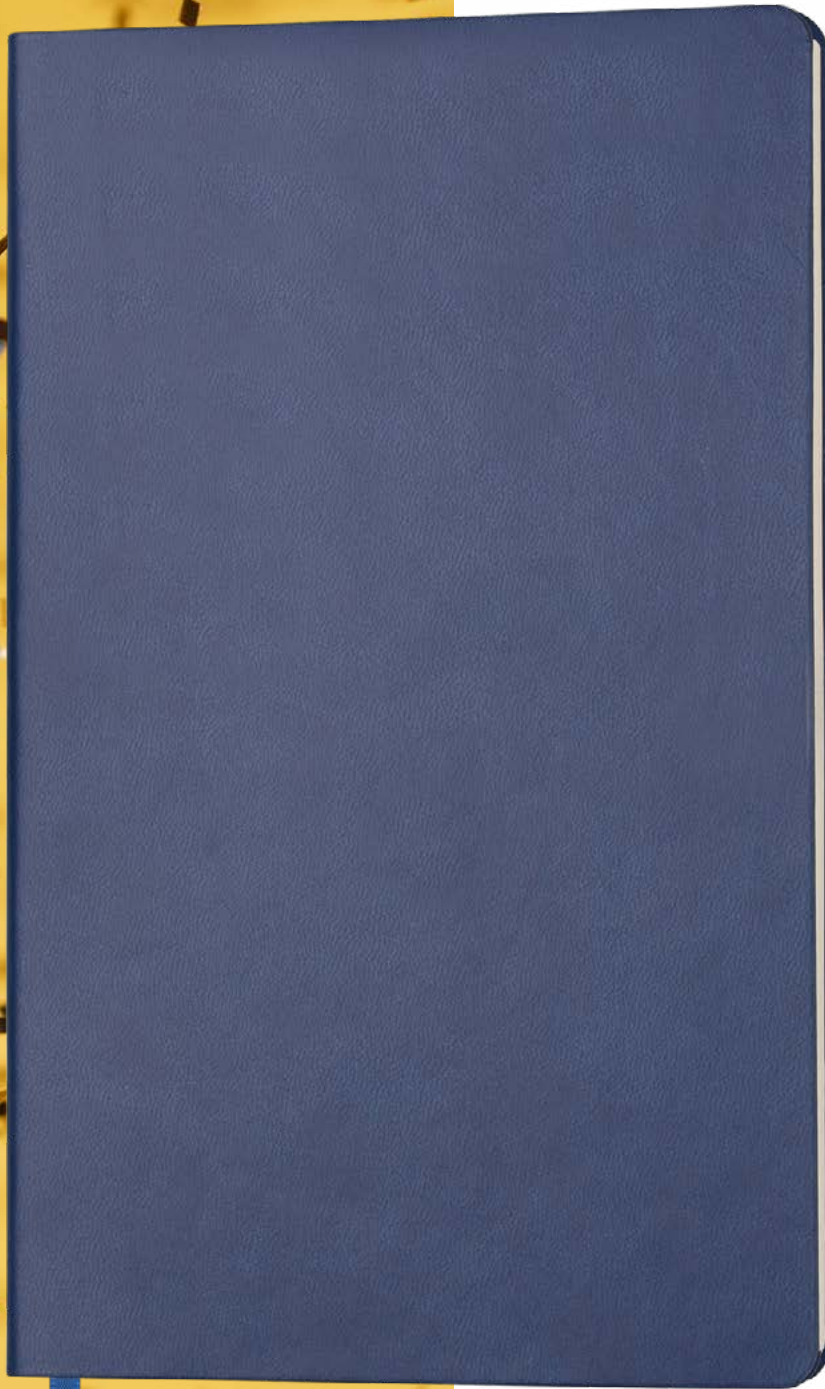

The mark of  
responsible forestry  
FSC® C118860

table of contents

Product code: TM21222/R..

# AUDREY GRS

Check it out



## Colors

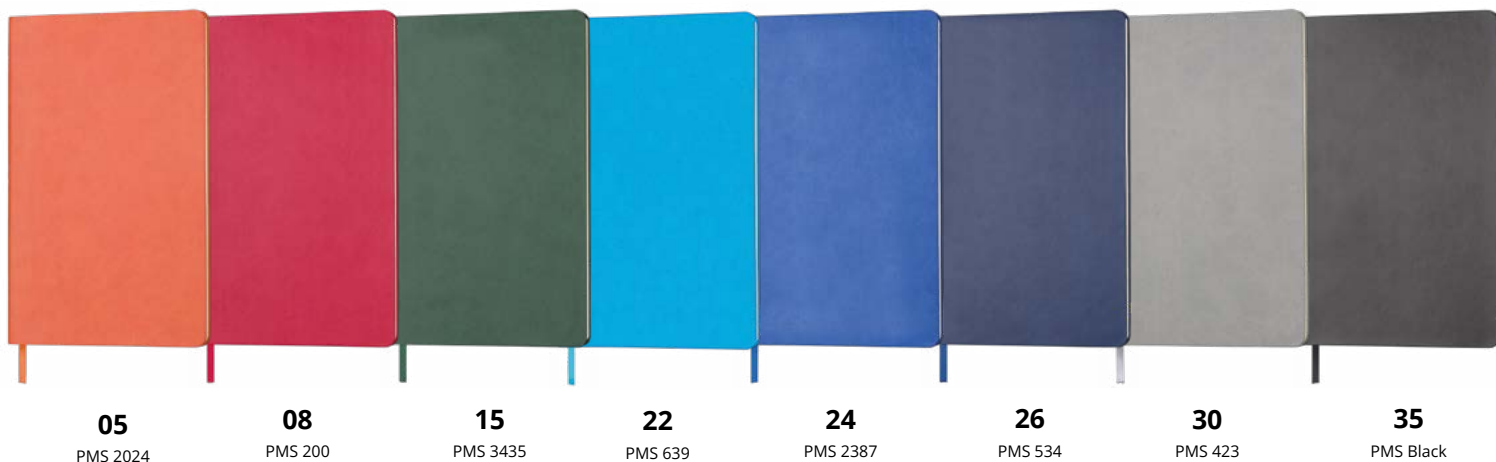

## Paper pattern

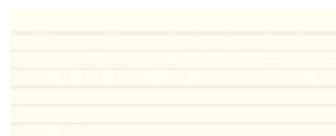

Lines

**EN**

Simple and practical, the notebook will fit into any handbag or backpack to be an everyday companion. The cover of the **GRS notebook** is made from **recycled materials** containing polyester from used plastic bottles. **Equivalent to the AUDREY notebook.**

**PL**

Prosty i praktyczny notes zmieści się w każdej torebce czy plecaku, by być towarzyszem każdego dnia. Okładka **notesu GRS** jest wykonana z **materiałów pochodzących z recyklingu**, zawierających poliester ze zużytych plastikowych butelek. **Odpowiednik notesu AUDREY.**

**IT**

Semplice e pratico, il taccuino si adatta a qualsiasi borsa o zaino per essere un compagno di tutti i giorni. La copertina del **taccuino GRS** è realizzata con **materiali riciclati** contenenti poliestere proveniente da bottiglie di plastica usate. **Equivalente al taccuino AUDREY.**

**FR**

Simple et pratique, le carnet se glissera dans n'importe quel sac à main ou sac à dos pour devenir un compagnon de tous les jours. La couverture du **carnet GRS** est fabriquée à partir de **matériaux recyclés** contenant du polyester provenant de bouteilles en plastique usagées. **Équivalent au carnet AUDREY.**

**DE**

Das schlichte und praktische Notizbuch passt in jede Handtasche oder jeden Rucksack und ist ein alltäglicher Begleiter. Der Einband des **GRS-Notizbuchs** besteht aus **recyclierten Materialien**, die Polyester aus gebrauchten Plastikflaschen enthalten. **Äquivalent zum AUDREY-Notizbuch.**

**ES**

Sencillo y práctico, el cuaderno cabe en cualquier bolso o mochila para ser un compañero diario. La cubierta del **cuaderno GRS** está fabricada con **materiales reciclados** que contienen poliéster procedente de botellas de plástico usadas. **Equivalente al cuaderno AUDREY.**

## Specification

|                       |              |                       |          |                       |              |                   |                       |                         |         |
|-----------------------|--------------|-----------------------|----------|-----------------------|--------------|-------------------|-----------------------|-------------------------|---------|
| <b>Dimensions</b>     | 130 x 210 mm | <b>Pages / sheets</b> | 128 / 64 | <b>Cover material</b> | GRS Recycled | <b>Cover type</b> | Flexible              | <b>Packaging (pcs.)</b> | 25 / 50 |
| <b>Pages material</b> | Paper FSC®   | <b>Paper color</b>    | Chamois  | <b>Paper density</b>  | 70g          | <b>Extras</b>     | Perforated sheets - 8 |                         |         |

## Branding options

### Front cover

|  |              |
|--|--------------|
| Digital overprint                      | 100 x 180 mm |
| Silkscreen printing                    | 100 x 180 mm |
| Embossing                              | 100 x 180 mm |
| Foil stamping ( <i>metallic foil</i> ) | 100 x 180 mm |

### Back cover

|  |              |
|--|--------------|
| Digital overprint                      | 100 x 150 mm |
| Silkscreen printing                    | 100 x 150 mm |
| Embossing                              | 100 x 150 mm |
| Foil stamping ( <i>metallic foil</i> ) | 100 x 150 mm |

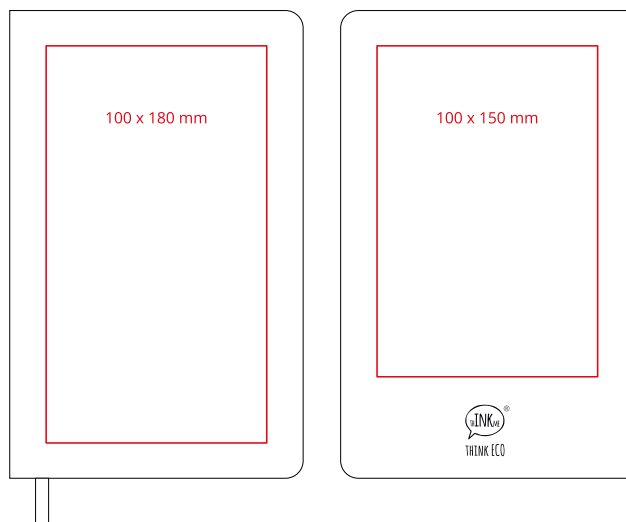

# FRANKY GRS

#recycled PU cover

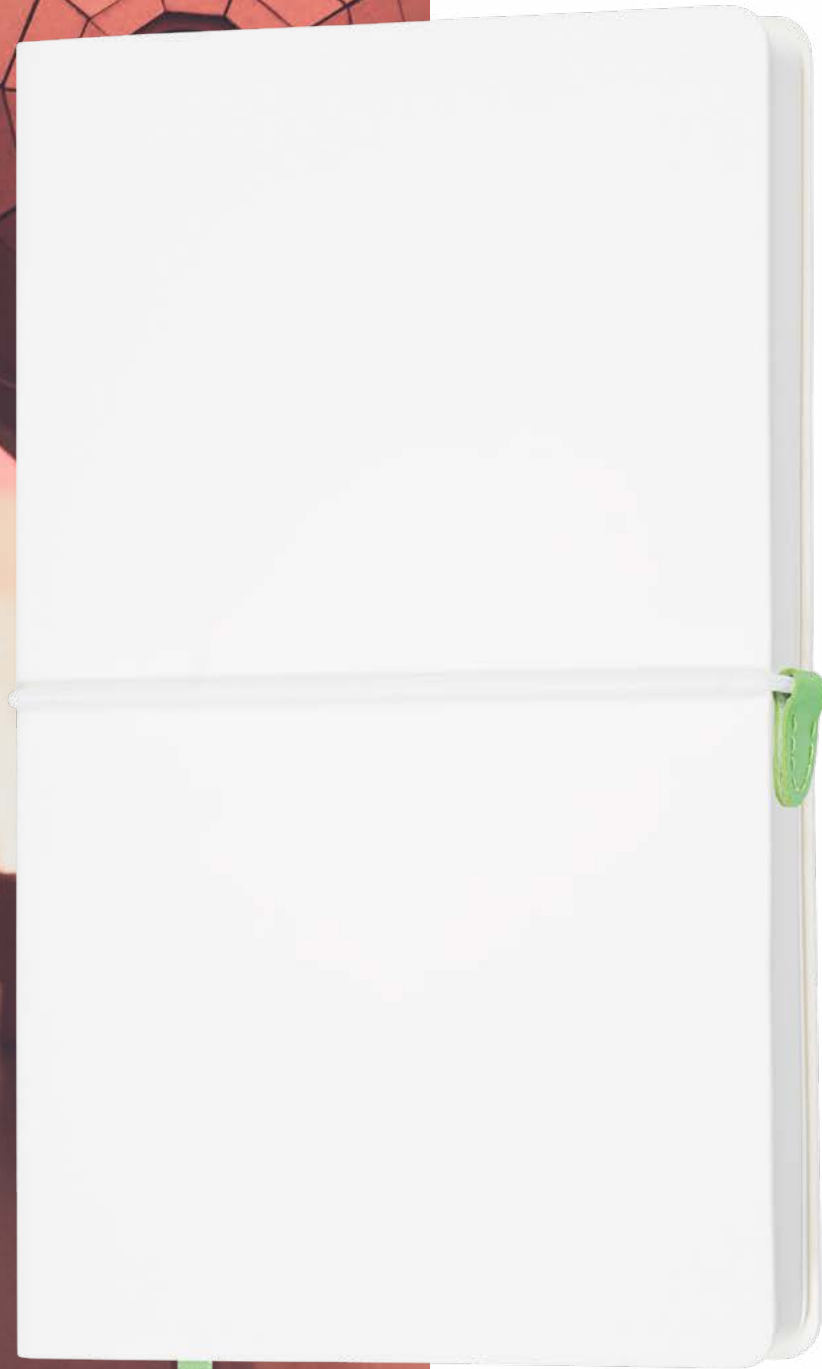

The mark of  
responsible forestry  
FSC® C118860

table of contents

Product code: TM21212/R..

# FRANKY GRS Announcement

check it out!

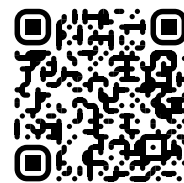

## Colors

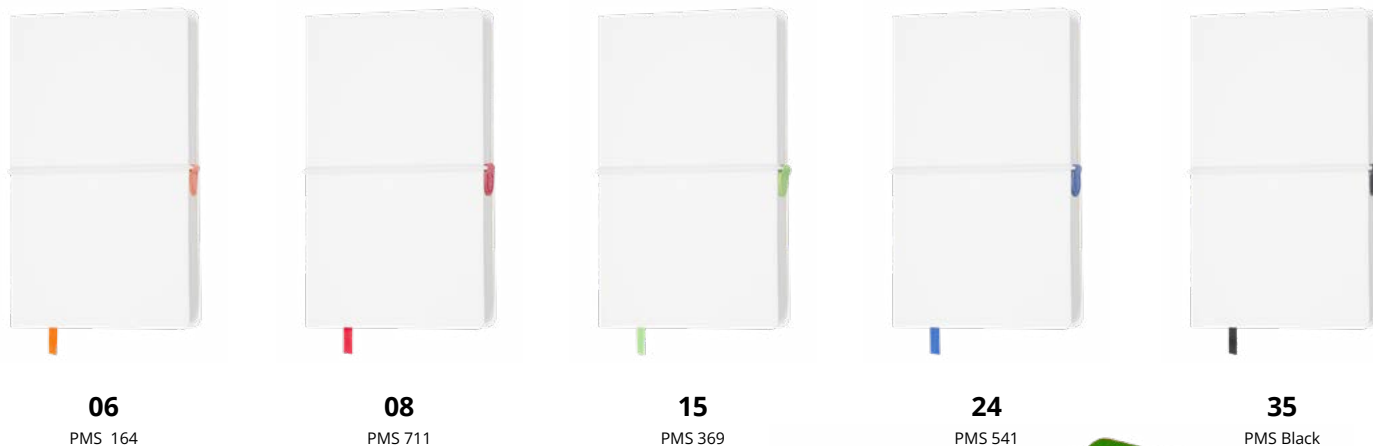
**06**

PMS 164

**08**

PMS 711

**15**

PMS 369

**24**

PMS 541

**35**

PMS Black

## Paper pattern

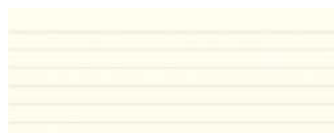

Lines

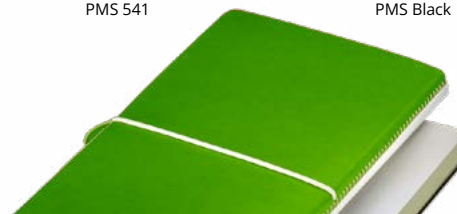
**EN**

Two-colored cover stylishly stitched along the spine, with smart features like a pocket and an elastic band, makes it a practical gadget. Contrasting colors attract attention, while the simplicity emphasizes its casual style. The GRS notebook cover is made from recycled materials, including polyester derived from used plastic bottles.

**PL**

Dwukolorowa okładka, stylowo przesyta wzdłuż grzbietu, z praktycznymi elementami, takimi jak kieszeń i elastyczna opaska, czyni z niej praktyczny gadżet. Kontrastujące kolory przyciągają uwagę, a prostota podkreśla swobodny styl. Okładka notesu GRS jest wykonana z materiałów pochodzących z recyklingu, w tym poliestru z przetworzonych butelek plastikowych.

**IT**

Copertina bicolore, elegantemente cucita lungo il dorso, con funzionalità pratiche come una tasca e una fascia elastica, la rende un gadget utile. I colori contrastanti attirano l'attenzione, mentre la semplicità enfatizza lo stile casual. La copertina del quaderno GRS è realizzata con materiali riciclati, inclusi poliestere derivato da bottiglie di plastica usate.

**FR**

Couverture bicolore, élégamment cousue le long du dos, avec des fonctionnalités pratiques comme une poche et un élastique, en fait un gadget pratique. Les couleurs contrastées attirent l'attention, tandis que la simplicité souligne son style décontracté. La couverture du carnet GRS est fabriquée à partir de matériaux recyclés, y compris du polyester issu de bouteilles en plastique usagées.

**DE**

Zweifarbige Hülle, stilvoll entlang des Buchrückens vernäht, mit praktischen Funktionen wie einer Tasche und einem Gummiband, macht sie zu einem nützlichen Gadget. Kontrastierende Farben ziehen die Aufmerksamkeit auf sich, während die Schlichtheit den lässigen Stil betont. Die GRS-Notizbuchhülle besteht aus recycelten Materialien, einschließlich Polyester aus gebrauchten Plastikflaschen.

**ES**

Cubierta bicolor, elegantemente cosida a lo largo del lomo, con características prácticas como un bolsillo y una banda elástica, lo convierte en un accesorio útil. Los colores contrastantes atraen la atención, mientras que la simplicidad enfatiza su estilo casual. La cubierta del cuaderno GRS está hecha de materiales reciclados, incluido poliéster derivado de botellas de plástico usadas.

## Specification

|                       |              |                       |           |                       |              |                   |  |                         |         |
|-----------------------|--------------|-----------------------|-----------|-----------------------|--------------|-------------------|--|-------------------------|---------|
| <b>Dimensions</b>     | 130 x 210 mm | <b>Pages / sheets</b> | 256 / 128 | <b>Cover material</b> | GRS Recycled | <b>Cover type</b> | Hard   | <b>Packaging (pcs.)</b> | 20 / 40 |
| <b>Pages material</b> | Paper FSC®   | <b>Paper color</b>    | Chamois   | <b>Paper density</b>  | 70g          | <b>Extras</b>     | Elastic white band - horizontal, Perforated sheets - 8, Expandable pocket, White front and colored back cover, Clip in cover color, Stitching on spine |                         |         |

## Branding options

### Front cover

|  |              |
|--|--------------|
| Digital overprint                      | 100 x 180 mm |
| Silkscreen printing                    | 100 x 180 mm |
| Embossing                              | 100 x 180 mm |
| Foil stamping ( <i>metallic foil</i> ) | 100 x 180 mm |

### Back cover

|  |              |
|--|--------------|
| Digital overprint                      | 100 x 155 mm |
| Silkscreen printing                    | 100 x 155 mm |
| Embossing                              | 100 x 155 mm |
| Foil stamping ( <i>metallic foil</i> ) | 100 x 155 mm |

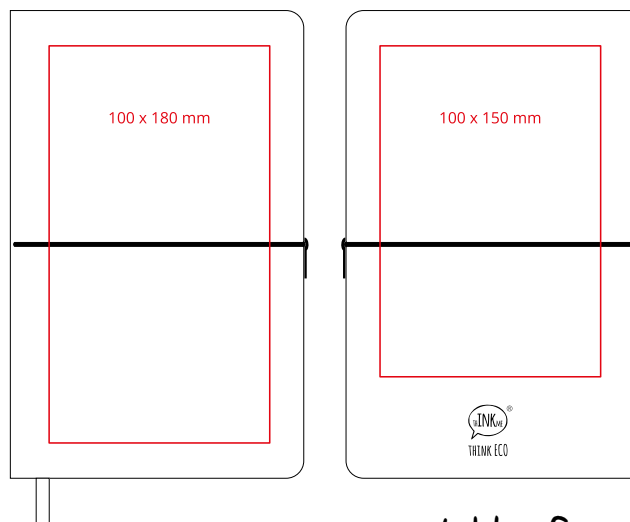
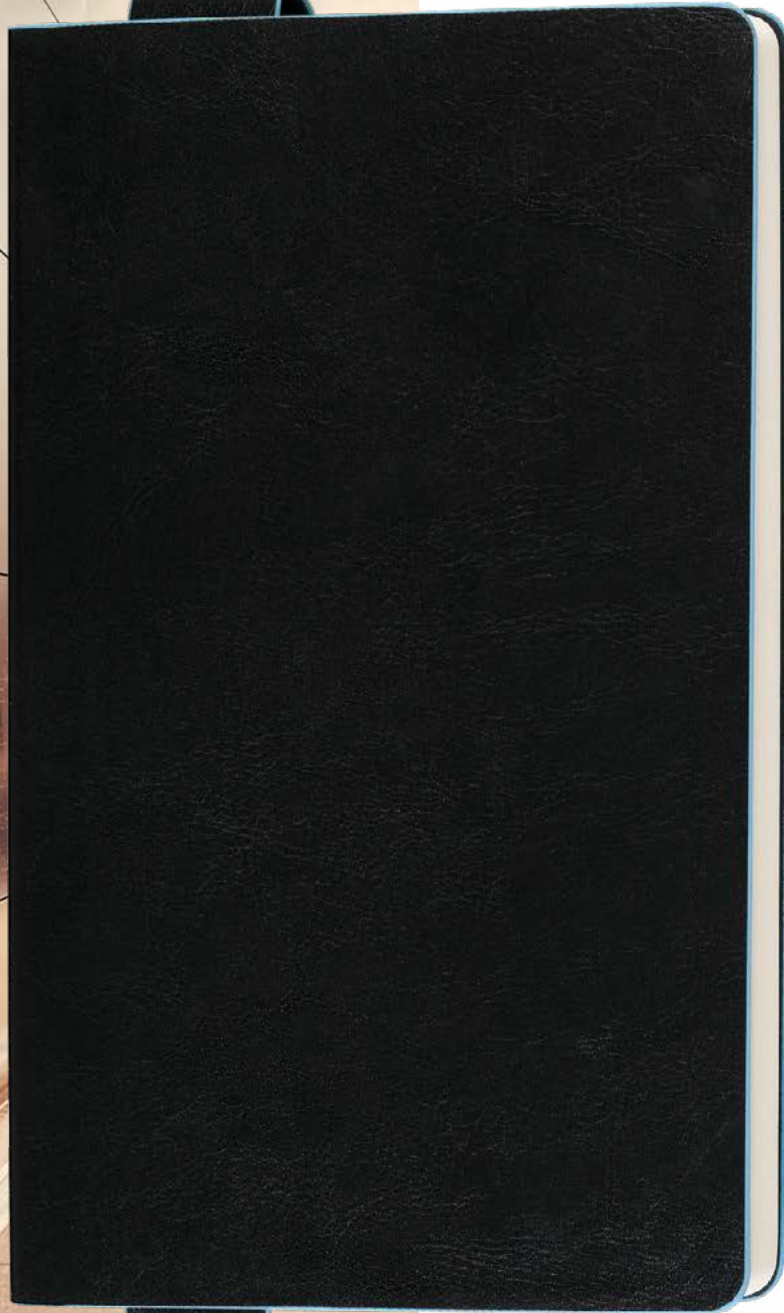

table of contents

# TRENDI GRS

#recycled PU cover



The mark of  
responsible forestry  
FSC® C118860

table of contents

Product code: TM21229/R.. | TM21229/..

# TRENDI GRS | TRENDI

Check it out



## Colors



**35/22**  
PMS 301



**35/15**  
PMS Green



**35/08**  
PMS 2035

Not GRS Cover While stocks last

## Paper pattern

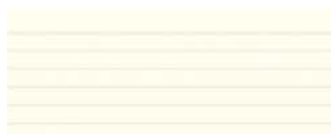

Lines

coloured endpapers!



EN

Black cover with coloured rounded edges, with a wide tab inside. The cover of the **GRS notebook** is made from **recycled materials** containing polyester from used plastic bottles. **The counterpart of the TRENDI notebook.**

PL

Czarna okładka w kolorowymi zaokrąglonymi krawędziami, z szeroką zakładką wewnątrz. Okładka notesu **GRS** jest wykonana z **materiałów pochodzących z recyklingu**, zawierających poliester ze zużytych plastikowych butelek. **Odpowiednik notesu TRENDI.**

IT

Copertina nera con bordi arrotondati colorati, con un'ampia linguetta all'interno. La copertina del **taccuino GRS** è realizzata con **materiali riciclati** contenenti poliestere proveniente da bottiglie di plastica usate. **La controparte del taccuino TRENDI.**

FR

Couverture noire avec bords arrondis colorés, avec un large onglet à l'intérieur. La couverture du **carnet GRS** est fabriquée à partir de **matériaux recyclés** contenant du polyester provenant de bouteilles en plastique usagées. **Le pendant du carnet TRENDI.**

DE

Schwarzer Einband mit farbigen, abgerundeten Kanten, mit einer breiten Lasche im Inneren. Der Einband des **GRS-Notizbuchs** besteht aus **recycelten Materialien**, die Polyester aus gebrauchten Plastikflaschen enthalten. **Das Gegenstück zum TRENDI-Notizbuch.**

ES

Cubierta negra con bordes redondeados de color, con una amplia lengüeta en el interior. La cubierta del **cuaderno GRS** está fabricada con **materiales reciclados** que contienen poliéster procedente de botellas de plástico usadas. **El homólogo del cuaderno TRENDI.**

## Specification

|                |              |                |           |                |              |            |                   |                  |         |
|----------------|--------------|----------------|-----------|----------------|--------------|------------|-------------------|------------------|---------|
| Dimensions     | 130 x 210 mm | Pages / sheets | 256 / 128 | Cover material | GRS Recycled | Cover type | Hard              | Packaging (pcs.) | 20 / 40 |
| Pages material | Paper FSC®   | Paper color    | Chamois   | Paper density  | 70g          | Extras     | Expandable pocket |                  |         |

## Branding options

### Front cover

|  |              |
|--|--------------|
| Digital overprint                      | 100 x 180 mm |
| Silkscreen printing                    | 100 x 180 mm |
| Embossing                              | 100 x 180 mm |
| Foil stamping ( <i>metallic foil</i> ) | 100 x 180 mm |

### Back cover

|  |              |
|--|--------------|
| Digital overprint                      | 100 x 115 mm |
| Silkscreen printing                    | 100 x 115 mm |
| Embossing                              | 100 x 115 mm |
| Foil stamping ( <i>metallic foil</i> ) | 100 x 115 mm |

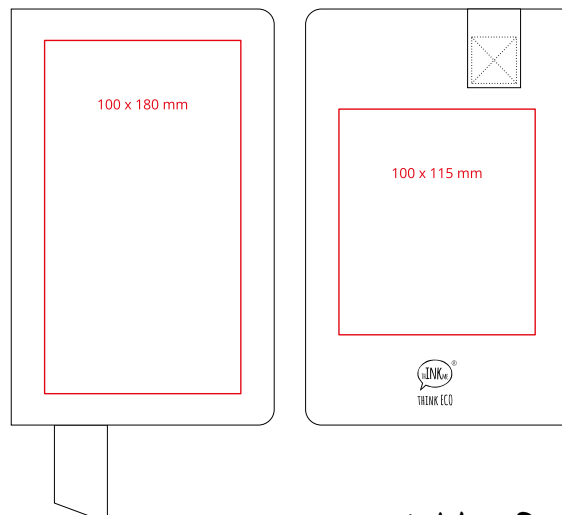



# TWIZZY

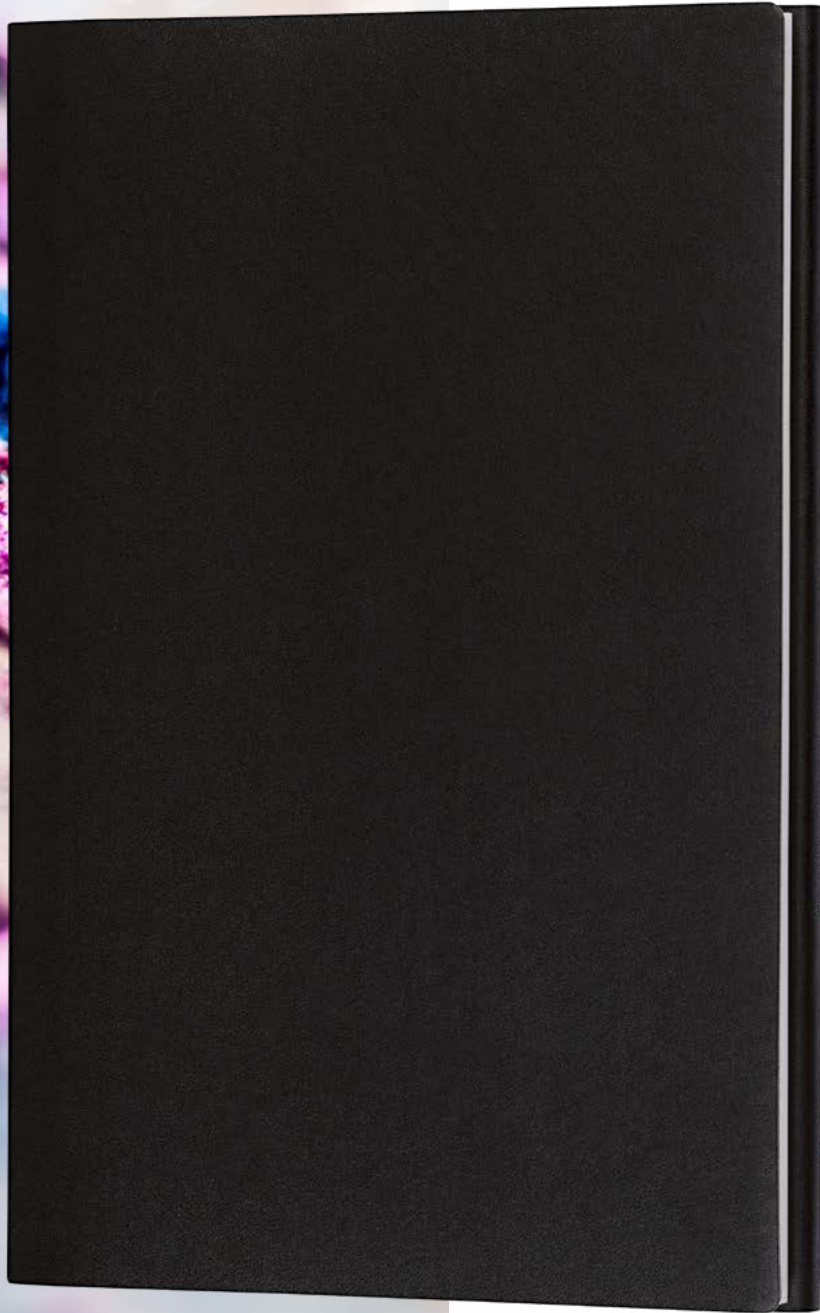

The mark of  
responsible forestry  
FSC® C118860

*table of contents*

Product code: TM22602/35

# TWIZZY

check it out!

While stocks last



## Colors



**35**  
PMS Black



## Paper pattern

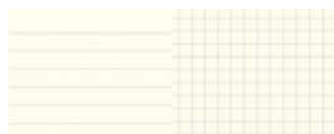

Lines/ Squaer

- EN**  
Double-sided notebook, soft cover, lined/squared.
- PL**  
Notes, miękka okładka, dwustronny, blok w linie i kratkę.
- IT**  
Quaderno a doppia facciata, copertina morbida, a righe/quadretti.
- FR**  
Cahier recto-verso, couverture souple, ligné/carré.
- DE**  
Notizbuch, weicher Einband, doppelseitig, Liniert und kariert.
- ES**  
Cuaderno de doble cara, tapa blanda, rayado/cuadrulado.

## Specification

|                       |              |                       |             |                       |                  |                   |               |                         |         |
|-----------------------|--------------|-----------------------|-------------|-----------------------|------------------|-------------------|---------------|-------------------------|---------|
| <b>Dimensions</b>     | 140 x 210 mm | <b>Pages / sheets</b> | 194 (96+96) | <b>Cover material</b> | Soft Stella (PU) | <b>Cover type</b> | Semi-Flexible | <b>Packaging (pcs.)</b> | 20 / 40 |
| <b>Pages material</b> | Paper FSC®   | <b>Paper color</b>    | Chamois     | <b>Paper density</b>  | 70g              | <b>Extras</b>     | Double sided  |                         |         |

## Branding options

### Front cover

- Digital overprint 100 x 180 mm
- Silkscreen printing 100 x 180 mm
- Embossing 100 x 180 mm
- Foil stamping (*metallic foil*) 100 x 180 mm

### Back cover

- Digital overprint 100 x 180 mm
- Silkscreen printing 100 x 180 mm
- Embossing 100 x 180 mm
- Foil stamping (*metallic foil*) 100 x 180 mm

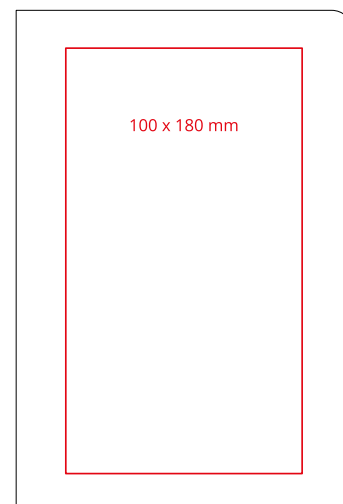
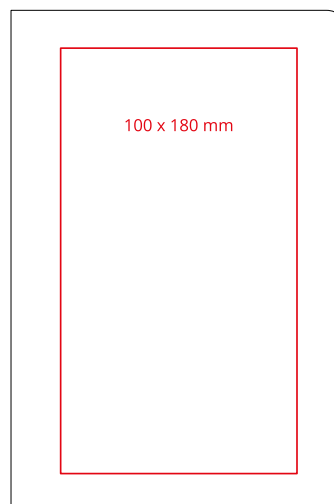

# COMBI

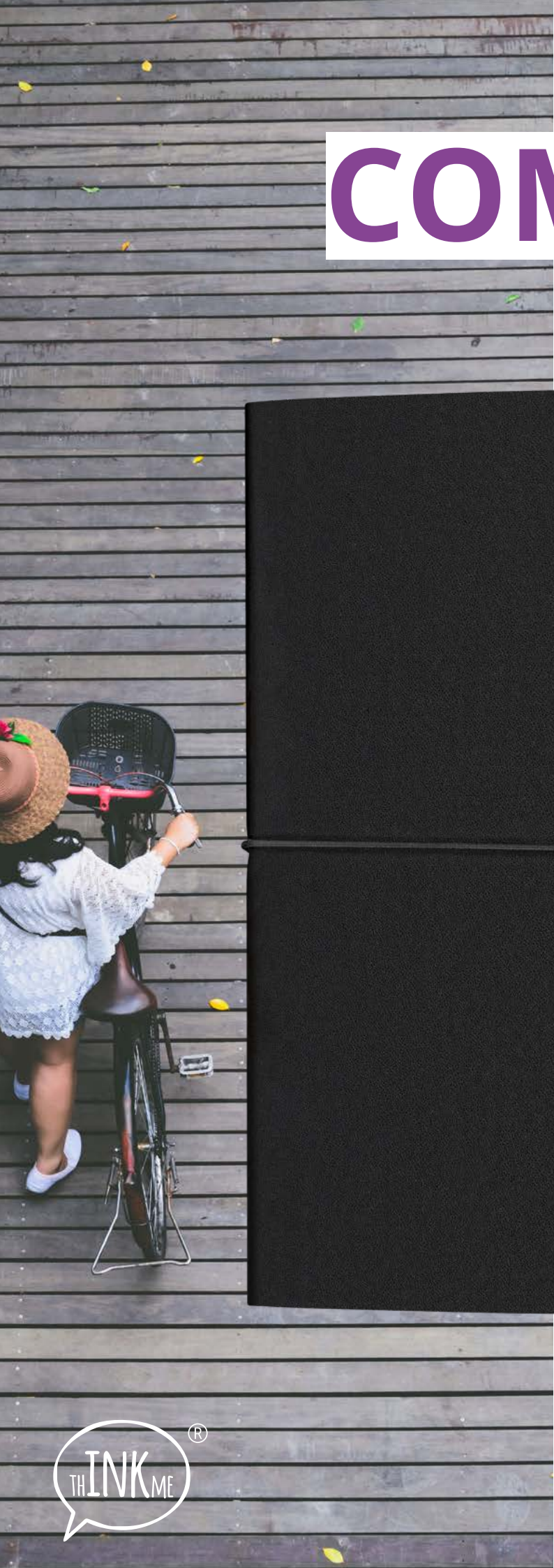

The mark of  
responsible forestry  
FSC® C118860

table of contents

Product code: TM21240/35

# COMBI

check it out!  
While stocks last



## Colors



**35**  
PMS Black

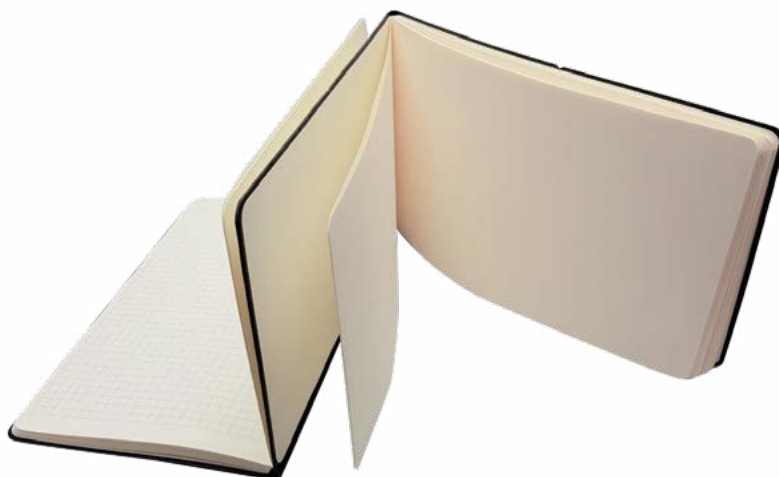

## Paper pattern



Squaer/ Blank perforated

- EN**  
Double-sided notebook, soft cover, blank/squared.
- PL**  
Notes, miękka okładka, dwustronny, blok gładki i w kratkę.
- IT**  
Quaderno bifacciale, copertina morbida, bianco/quadro.
- FR**  
Cahier recto-verso, couverture souple, vierge/carré.
- DE**  
Notizbuch, Softcover, doppelseitig, einfarbig und Liniert.
- ES**  
Cuaderno de doble cara, tapa blanda, en blanco/cuadrulado.

## Specification

|                |              |                |             |                |                  |            |   |                  |         |
|----------------|--------------|----------------|-------------|----------------|------------------|------------|---|------------------|---------|
| Dimensions     | 130 x 210 mm | Pages / sheets | 194 (96+96) | Cover material | Soft Stella (PU) | Cover type | Semi-Flexible                                 | Packaging (pcs.) | 25 / 50 |
| Pages material | Paper FSC®   | Paper color    | Chamois     | Paper density  | 70g              | Extras     | Elastic black band - horizontal, Double sided |                  |         |

## Branding options

### Front cover

- Digital overprint 100 x 180 mm
- Silkscreen printing 100 x 180 mm
- Embossing 100 x 180 mm
- Foil stamping (metallic foil) 100 x 180 mm

### Back cover

- Digital overprint 100 x 160 mm
- Silkscreen printing 100 x 160 mm
- Embossing 100 x 160 mm
- Foil stamping (metallic foil) 100 x 160 mm

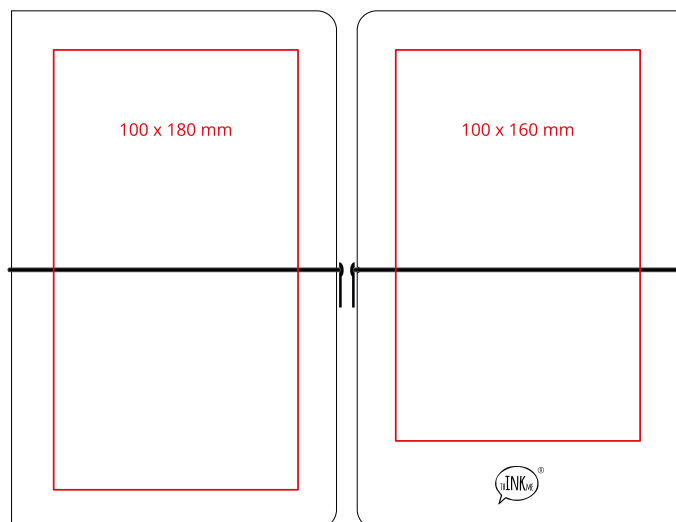

# BLACKY

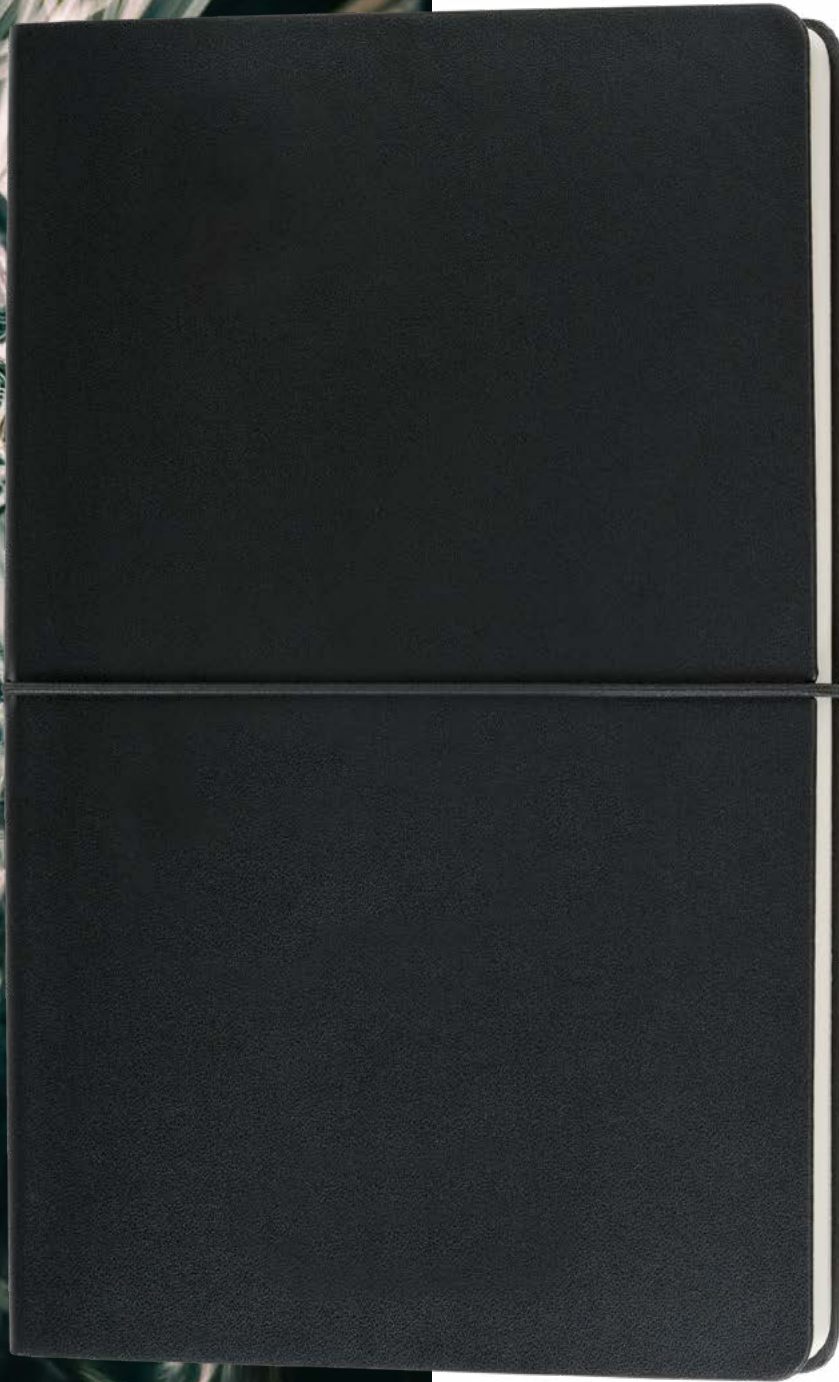

The mark of  
responsible forestry  
FSC® C118860

*table of contents*

Product code: TM22600/35

# BLACKY

check it out!  
While stocks last



## Colors



**35**  
PMS Black



## Paper pattern



Squaer

- EN**  
Notebook, soft black cover with black horizontal band, squared.
- PL**  
Notes, miękka czarna okładka z czarną poziomą gumką, blok w kratkę.
- IT**  
Quaderno, copertina morbida nera con banda orizzontale nera, quadrettato.
- FR**  
Carnet de notes, couverture noire souple avec bande horizontale noire, quadrillé.
- DE**  
Notizbuch, weicher schwarzer Einband mit schwarzem horizontalen Gummiband, kariertes Block.
- ES**  
Cuaderno, tapa blanda negra con banda horizontal negra, cuadrulado.

## Specification

|                |              |                |          |                |                      |            |   |                  |         |
|----------------|--------------|----------------|----------|----------------|----------------------|------------|---|------------------|---------|
| Dimensions     | 140 x 210 mm | Pages / sheets | 192 / 96 | Cover material | Flexible Stella (PU) | Cover type | Semi-Flexible   | Packaging (pcs.) | 20 / 40 |
| Pages material | Paper FSC®   | Paper color    | Chamois  | Paper density  | 70g                  | Extras     | Perforated sheets - 8, Expandable pocket, Elastic black band - horizontal |                  |         |

## Branding options

### Front cover

- Digital overprint 110 x 180 mm
- Silkscreen printing 110 x 180 mm
- Embossing 110 x 180 mm
- Foil stamping (*metallic foil*) 110 x 180 mm

### Back cover

- Digital overprint 110 x 160 mm
- Silkscreen printing 110 x 160 mm
- Embossing 110 x 160 mm
- Foil stamping (*metallic foil*) 110 x 160 mm

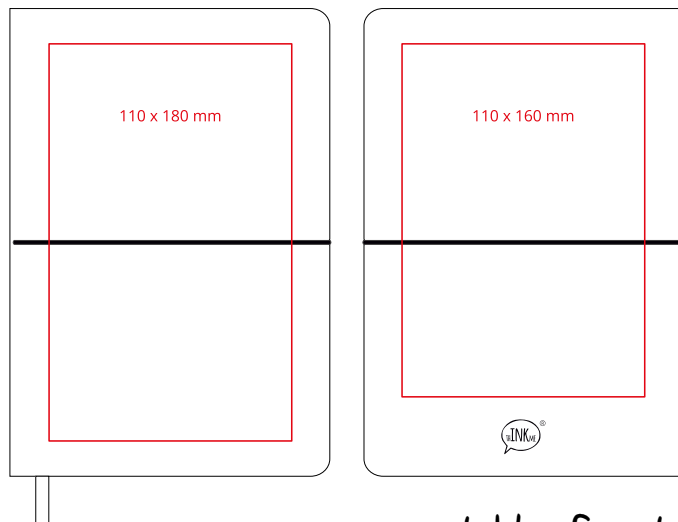

table of contents

# JUSTY GRS

#recycled PU cover



The mark of  
responsible forestry  
FSC® C118860

Product code: TM21210R/..

# JUSTY GRS

Check it out



## Colors



|                      |                      |                      |                      |                       |                       |                      |                      |                        |
|----------------------|----------------------|----------------------|----------------------|-----------------------|-----------------------|----------------------|----------------------|------------------------|
| <b>03</b><br>PMS 012 | <b>05</b><br>PMS 165 | <b>08</b><br>PMS 200 | <b>15</b><br>PMS 560 | <b>22</b><br>PMS 7688 | <b>24</b><br>PMS 3506 | <b>26</b><br>PMS 534 | <b>30</b><br>PMS 423 | <b>35</b><br>PMS Black |
|----------------------|----------------------|----------------------|----------------------|-----------------------|-----------------------|----------------------|----------------------|------------------------|

## Paper pattern

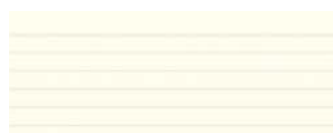

Lines



Squaer



Dots

|   |  |  |   |  |   |
|---|--|--|---|--|---|
| <b>EN</b><br>Hardcover notebook with elastic band, pen holder and ribbon, slip pocket and envelope on the back. Cover material <b>Hard Velvet (PU)</b> . The GRS notebook cover is made from <b>recycled materials</b> containing polyester from used plastic bottles. <b>The equivalent of the JUSTY notebook.</b> | <b>PL</b><br>Notes w twardej okładce z gumką, uchwytem na długopis i wstążką, wsuwana kieszeń i koperta z tyłu. Materiał okładki <b>Hard Velvet (PU)</b> . Okładka notesu GRS jest wykonana z <b>materiałów pochodzących z recyklingu</b> , zawierających poliester ze zużytych plastikowych butelek. <b>Odpowiednik notesu JUSTY.</b> | <b>IT</b><br>Taccuino con copertina rigida, elastico, portapenna e nastro, tasca e busta sul retro. Materiale della copertina <b>Hard Velvet (PU)</b> . La copertina del taccuino GRS è realizzata con <b>materiali riciclati</b> contenenti poliestere proveniente da bottiglie di plastica usate. <b>L'equivalente del taccuino JUSTY.</b> | <b>FR</b><br>Cahier à couverture rigide avec élastique, porte-stylo et ruban, pochette et enveloppe au dos. Couverture en <b>velours dur (PU)</b> . La couverture du carnet GRS est fabriquée à partir de <b>matériaux recyclés</b> contenant du polyester provenant de bouteilles en plastique usagées. <b>L'équivalent du carnet JUSTY.</b> | <b>DE</b><br>Hardcover-Notizbuch mit Gummiband, Stifthalter und Lesebändchen, Einstecktasche und Umschlag auf der Rückseite. Einbandmaterial <b>Hard Velvet (PU)</b> . Der GRS-Notizbucheinband wird aus <b>recyclelten Materialien</b> hergestellt, die Polyester aus gebrauchten Plastikflaschen enthalten. <b>Das Äquivalent zum JUSTY-Notizbuch.</b> | <b>ES</b><br>Cuaderno de tapa dura con banda elástica, portabolígrafos y cinta, bolsillo portaobjetos y sobre en la parte posterior. Material de la cubierta <b>Terciopelo duro (PU)</b> . La cubierta del cuaderno GRS está fabricada con <b>materiales reciclados</b> que contienen poliéster procedente de botellas de plástico usadas. <b>El equivalente al cuaderno JUSTY.</b> |
|---|--|--|---|--|---|

## Specification

|                       |              |                       |           |                       |              |                   |   |                         |         |
|-----------------------|--------------|-----------------------|-----------|-----------------------|--------------|-------------------|---|-------------------------|---------|
| <b>Dimensions</b>     | 130 x 210 mm | <b>Pages / sheets</b> | 256 / 128 | <b>Cover material</b> | GRS Recycled | <b>Cover type</b> | Hard  | <b>Packaging (pcs.)</b> | 26 / 50 |
| <b>Pages material</b> | Paper FSC®   | <b>Paper color</b>    | Chamois   | <b>Paper density</b>  | 70g          | <b>Extras</b>     | Elastic band, same color as cover - vertical, Perforated sheets - 8, Expandable pocket, Ribbon, same color as cover |                         |         |

## Branding options

### Front cover

|  |              |
|--|--------------|
| Digital overprint                      | 100 x 180 mm |
| Silkscreen printing                    | 100 x 180 mm |
| Embossing                              | 100 x 180 mm |
| Foil stamping ( <i>metallic foil</i> ) | 100 x 180 mm |

### Back cover

|  |             |
|--|-------------|
| Digital overprint                      | 90 x 150 mm |
| Silkscreen printing                    | 90 x 150 mm |
| Embossing                              | 90 x 150 mm |
| Foil stamping ( <i>metallic foil</i> ) | 90 x 150 mm |

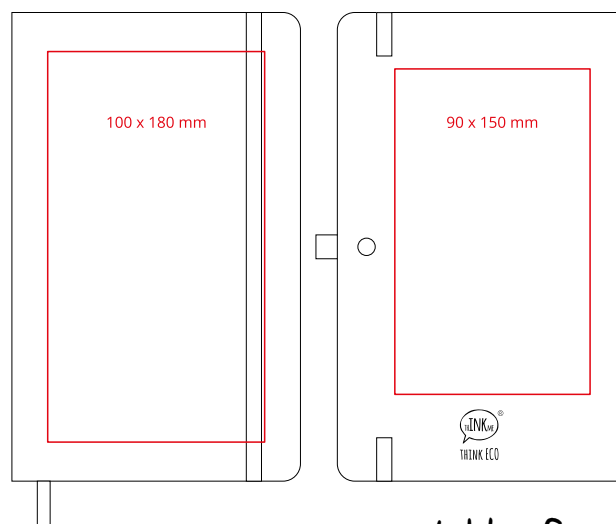

table of contents



# SILKY GRS

#recycled PU cover



The mark of  
responsible forestry  
FSC® C118860

table of contents

Product code: TM21215/R..

# SILKY GRS

Check it out



## Colors

**06**

PMS 1585

**08**

PMS 186

**24**

PMS 2384

**26**

PMS 288

**35**

PMS Black

## Paper pattern



Squaer

**EN**

The smooth and delicate cover attracts the attention of those who are guided by their senses to explore the world around them. Close your eyes and surrender to your senses! The cover of the **GRS notebook** is made from **recycled materials** containing polyester from used plastic bottles. **The equivalent of the SILKY notebook.**

**PL**

Gładka i delikatna okładka przyciąga uwagę tych, którzy kierując się zmysłami poznają otaczający ich świat. Zamknij oczy i oddaj się zmysłom! Okładka **notesu GRS** jest wykonana z **materiałów pochodzących z recyklingu**, zawierających poliester ze zużytych plastikowych butelek. **Odpowiednik notesu SILKY.**

**IT**

La copertina liscia e delicata attira l'attenzione di chi si lascia guidare dai sensi per esplorare il mondo circostante. Chiudete gli occhi e abbandonatevi ai vostri sensi! La copertina del **taccuino GRS** è realizzata con **materiali riciclati** contenenti poliestere proveniente da bottiglie di plastica usate. **L'equivalente del taccuino SILKY.**

**FR**

La couverture lisse et délicate attire l'attention de ceux qui se laissent guider par leurs sens pour explorer le monde qui les entoure. Fermez les yeux et abandonnez-vous à vos sens ! La couverture du **carnet GRS** est fabriquée à partir de **matériaux recyclés** contenant du polyester provenant de bouteilles en plastique usagées. **L'équivalent du carnet SILKY.**

**DE**

Das glatte und zarte Cover zieht die Aufmerksamkeit derjenigen auf sich, die sich von ihren Sinnen leiten lassen, um die Welt um sich herum zu erkunden. Schließen Sie die Augen und geben Sie sich Ihren Sinnen hin! Der Einband des **GRS-Notizbuchs** besteht aus **recycelten Materialien**, die Polyester aus gebrauchten Plastikflaschen enthalten. **Das Pendant zum SILKY-Notizbuch.**

**ES**

Su cubierta suave y delicada atrae la atención de quienes se guían por sus sentidos para explorar el mundo que les rodea. Cierra los ojos y ríndete a tus sentidos! La cubierta del **cuaderno GRS** está fabricada con **materiales reciclados** que contienen poliéster procedente de botellas de plástico usadas. **El equivalente al cuaderno SILKY.**

## Specification

|                       |              |                       |           |                       |              |                   |  |                         |         |
|-----------------------|--------------|-----------------------|-----------|-----------------------|--------------|-------------------|--|-------------------------|---------|
| <b>Dimensions</b>     | 130 x 210 mm | <b>Pages / sheets</b> | 256 / 128 | <b>Cover material</b> | GRS Recycled | <b>Cover type</b> | Hard   | <b>Packaging (pcs.)</b> | 20 / 40 |
| <b>Pages material</b> | Paper FSC®   | <b>Paper color</b>    | Chamois   | <b>Paper density</b>  | 70g          | <b>Extras</b>     | Elastic band, same color as cover - vertical, Perforated sheets - 8, Expandable pocket, Pen holder |                         |         |

## Branding options

### Front cover

|  |              |
|--|--------------|
| Digital overprint                      | 100 x 180 mm |
| Silkscreen printing                    | 100 x 180 mm |
| Embossing                              | 100 x 180 mm |
| Foil stamping ( <i>metallic foil</i> ) | 100 x 180 mm |

### Back cover

|  |             |
|--|-------------|
| Digital overprint                      | 75 x 150 mm |
| Silkscreen printing                    | 75 x 150 mm |
| Embossing                              | 75 x 150 mm |
| Foil stamping ( <i>metallic foil</i> ) | 75 x 150 mm |

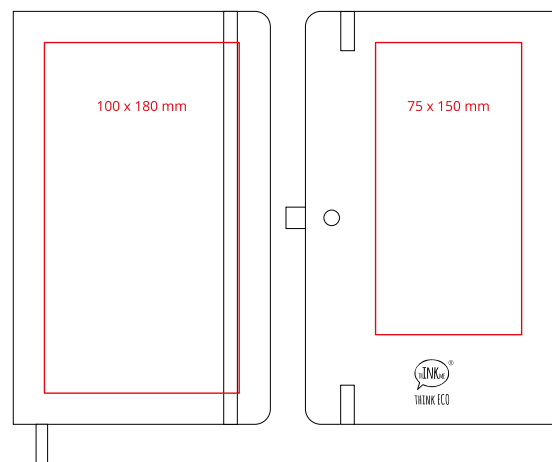

Product code: TM23100/..

# SOFTI Powerbank

check it out!



## Colors



**01**  
White



**03**  
Yellow



**06**  
Orange



**08**  
Red



**10**  
Pink



**11**  
Purple



**15**  
Green



**22**  
Light Blue



**24**  
Blue



**25**



**26**  
Dark Blue



**30**  
Grey



**35**  
Black

EN

A power bank with a plastic casing and a cover made from notebook cover material. Its shape and design resemble a notebook, and the combination of materials and colors allows for creating perfect sets.

PL

Power bank z plastikową obudową i okładką z materiału okładek dla notesów. Kształtem i designem przypomina notes, a dopasowanie materiałów i kolorów pozwala na tworzenie idealnych zestawów.

IT

Un power bank con custodia in plastica e copertina in materiale per copertine di quaderni. La sua forma e il design ricordano un quaderno, e la combinazione di materiali e colori consente di creare set perfetti.

FR

Une batterie externe avec un boîtier en plastique et une couverture en matériau de couverture pour carnets. Sa forme et son design rappellent un carnet, et l'association de matériaux et des couleurs permet de créer des ensembles parfaits.

DE

Eine Powerbank mit einem Kunststoffgehäuse und einem Umschlag aus Notizbuchumschlagmaterial. Ihre Form und ihr Design ähneln einem Notizbuch, und die Kombination von Materialien und Farben ermöglicht die Erstellung perfekter Sets.

ES

Un power bank con carcasa de plástico y cubierta de material utilizado para cubiertas de cuadernos. Su forma y diseño recuerdan a un cuaderno, y la combinación de materiales y colores permite crear conjuntos perfectos.

## Specification

**Dimensions** 75 x 121 x 11 mm

**Battery** Li-polymer

**Cover material** Soft Velvet PU

**Pojemność (mAh)** 5000 mAh

**Input / output voltage** 5V, 2.1A / 5V, 2.1A

**Packaging (pcs.)** 1 / 40

**Features** 4 LED indicators, Shake switch on, Auto switch off, Micro USB cord

## Branding options

### Front cover

|  |             |
|--|-------------|
| Digital overprint  | 60 x 110 mm |
| Silkscreen printing (except Provence)                    | 60 x 110 mm |
| Embossing  | 60 x 110 mm |
| Foil stamping ( <i>metallic foil</i> ) (except Provence) | 60 x 110 mm |

### Back cover

|  |             |
|--|-------------|
| Digital overprint  | 60 x 110 mm |
| Silkscreen printing (except Provence)                    | 60 x 110 mm |
| Embossing  | 60 x 110 mm |
| Foil stamping ( <i>metallic foil</i> ) (except Provence) | 60 x 110 mm |

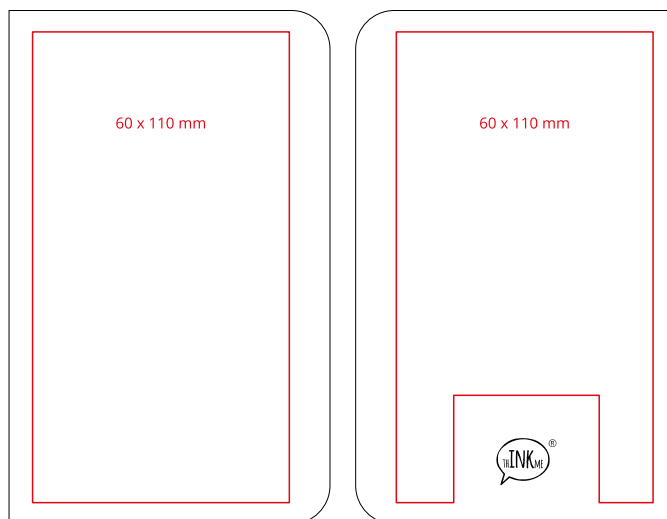

table of contents

Product code: TM23102/..

# SILKY Powerbank

## Colors

Cover material Hard Silk Touch PU

*check it out!***08**  
Red**15**  
Green**24**  
Blue**26**  
Dark blue**35**  
Black

Product code: TM23103/..

# PROVENCE Powerbank

## Colors

Cover material Structured Flexible PU

*check it out!***03**  
Yellow**10**  
Pink**126**  
Purple**16**  
Light Green**25**  
Dark Blue

Product code: TM23104/..

# FRANKY Powerbank

## Colors

Cover material Soft Velvet PU

*check it out!***06**  
Orange**08**  
Red**15**  
Green**24**  
Blue**35**  
Black*table of contents*

Product code: TM23200.. | TMSG23200..

# SHAKY Color | SHAKY Color Soft

Special  
production

check it out!



## Colors



**120**  
Yellow



**05**  
Orange



**08**  
Red



**35**  
Black

EN

PowerBank in a plastic housing, white interior, colored cover.

PL

PowerBank w plastikowej obudowie, wewnątrz białe, okładka w kolorze.

IT

PowerBank con alloggiamento in plastica, interno bianco, coperchio colorato.

FR

PowerBank dans un boîtier en plastique, intérieur blanc, couvercle coloré.

DE

PowerBank im Kunststoffgehäuse, innen weiß, Deckel farbig.

ES

PowerBank en carcasa de plástico, interior blanco, tapa de color.

## Specification

|                        |                  |                               |  |                         |        |
|------------------------|------------------|-------------------------------|--|-------------------------|--------|
| <b>Dimensions</b>      | 75 x 121 x 11 mm | <b>Battery</b>                | Li-polymer   | <b>Cover material</b>   | ABS    |
| <b>Pojemność (mAh)</b> | 4000 mAh         | <b>Input / output voltage</b> | 5V, 2.1A / 5V, 2.1A  | <b>Packaging (pcs.)</b> | 1 / 40 |
|                        |                  | <b>Features</b>               | 4 LED indicators, Shake switch on, Auto switch off, Micro USB cord |                         |        |

## Branding options

### Front cover

Digital overprint  
Silkscreen printing

60 x 100 mm  
60 x 100 mm

### Back cover

Digital overprint  
Silkscreen printing

60 x 80 mm  
60 x 80 mm

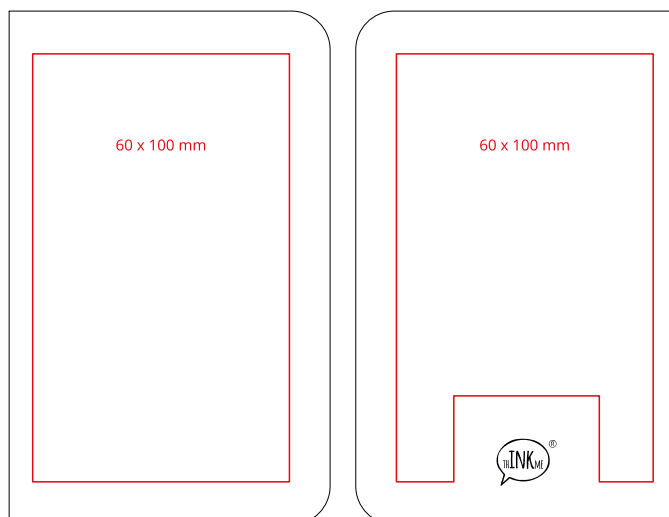

Product code: TMST232/01 | TML232/95

# SHAKY SafeTouch | SHAKY Lighting ST

Special production

check it out!



## Colors



- EN**

Antibacterial PowerBank in white color.
- PL**

Antybakteryjny PowerBank w białym kolorze.
- IT**

PowerBank antibatterico di colore bianco.
- FR**

PowerBank antibactérien de couleur blanche.
- DE**

Antibakterielle PowerBank in Weiß.
- ES**

PowerBank antibacteriano en color blanco.

## Specification

|                 |                  |                        |                     |                  |                        |  |
|-----------------|------------------|------------------------|---------------------|------------------|------------------------|--|
| Dimensions      | 75 x 121 x 11 mm | Battery                | Li-polymer          | Cover material   | ABS with antibacterial |  |
| Pojemność (mAh) | 4000 mAh         | Input / output voltage | 5V, 2.1A / 5V, 2.1A | Packaging (pcs.) | 1 / 40                 |  |
|                 |                  |                        |                     |                  | Features               | 4 LED indicators, Shake switch on, Auto switch off, Micro USB cord |

## Branding options

### Front cover

- Digital overprint 60 x 100 mm
- Silkscreen printing 60 x 100 mm
- Laser engraving 40 x 60 mm

### Back cover

- Digital overprint 60 x 80 mm
- Silkscreen printing 60 x 80 mm

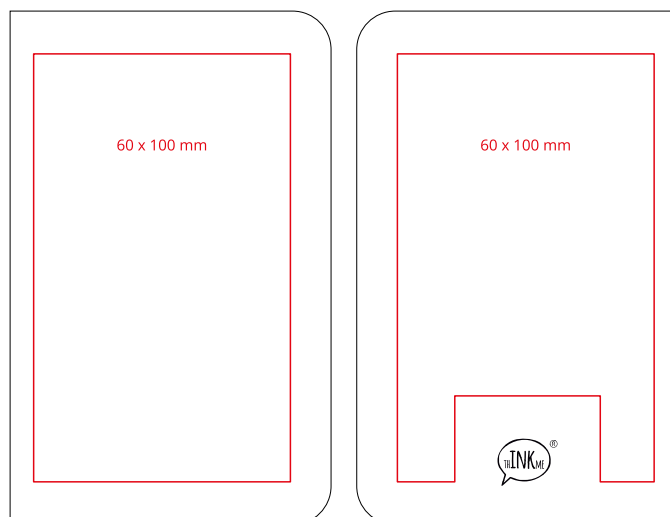

Sell-out  
see more QR



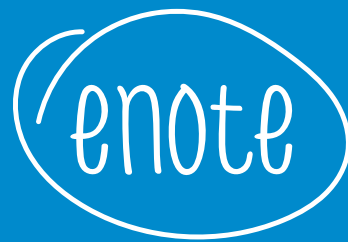

Notebooks designed for professional business use  
– where style meets functionality.



# SIMPLY



*While stocks last*



*table of contents*

Product code: EN21216/..

# SIMPLY

## Colors



**08**  
PMS 200



**25**  
PMS 2154



**35**  
PMS Black

check it out!



## Paper pattern



Squaer

- EN**  
Notebook with decorative seam. **White sleeve with the possibility of marking.**
- PL**  
Notes z ozdobnym przeszyciem. **Biała obwoluta z możliwością znakowania.**
- IT**  
Quaderno con cucitura decorativa.  **Custodia bianca con possibilità di marcatura.**
- FR**  
Carnet de notes avec couture décorative. **Pochette blanche avec possibilité de marquage.**
- DE**  
Notizblock mit dekorativer Naht. **Weiße Hülle mit Markierungsmöglichkeiten.**
- ES**  
Libreta con costura decorativa. **Funda blanca con posibilidad de marcaje.**

## Specification

|                       |              |                       |          |                       |                  |                   |                 |                         |         |
|-----------------------|--------------|-----------------------|----------|-----------------------|------------------|-------------------|-----------------|-------------------------|---------|
| <b>Dimensions</b>     | 130 x 210 mm | <b>Pages / sheets</b> | 192 / 96 | <b>Cover material</b> | Semielastic (PU) | <b>Cover type</b> | Semi-flexible   | <b>Packaging (pcs.)</b> | 20 / 40 |
| <b>Pages material</b> | Paper        | <b>Paper color</b>    | Chamois  | <b>Paper density</b>  | 70g              | <b>Extras</b>     | Decorative seam |                         |         |

## Branding options

### Front cover

|  |              |
|--|--------------|
| Digital overprint                      | 100 x 180 mm |
| Silkscreen printing                    | 100 x 180 mm |
| Embossing                              | 100 x 180 mm |
| Foil stamping ( <i>metallic foil</i> ) | 100 x 180 mm |

### Back cover

|  |              |
|--|--------------|
| Digital overprint                      | 100 x 160 mm |
| Silkscreen printing                    | 100 x 160 mm |
| Embossing                              | 100 x 160 mm |
| Foil stamping ( <i>metallic foil</i> ) | 100 x 160 mm |

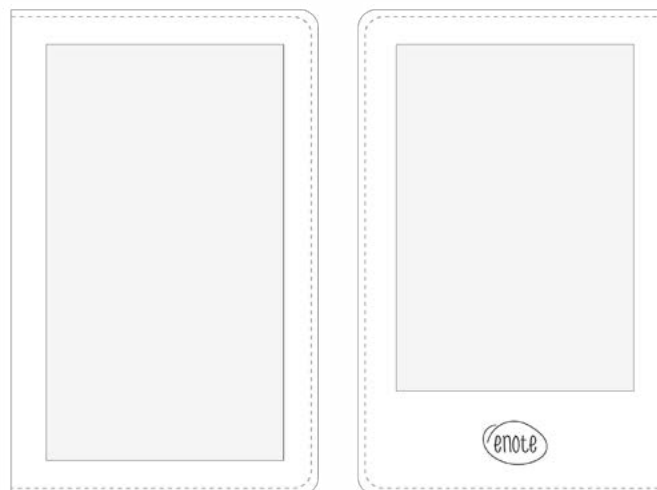

# MELLOW

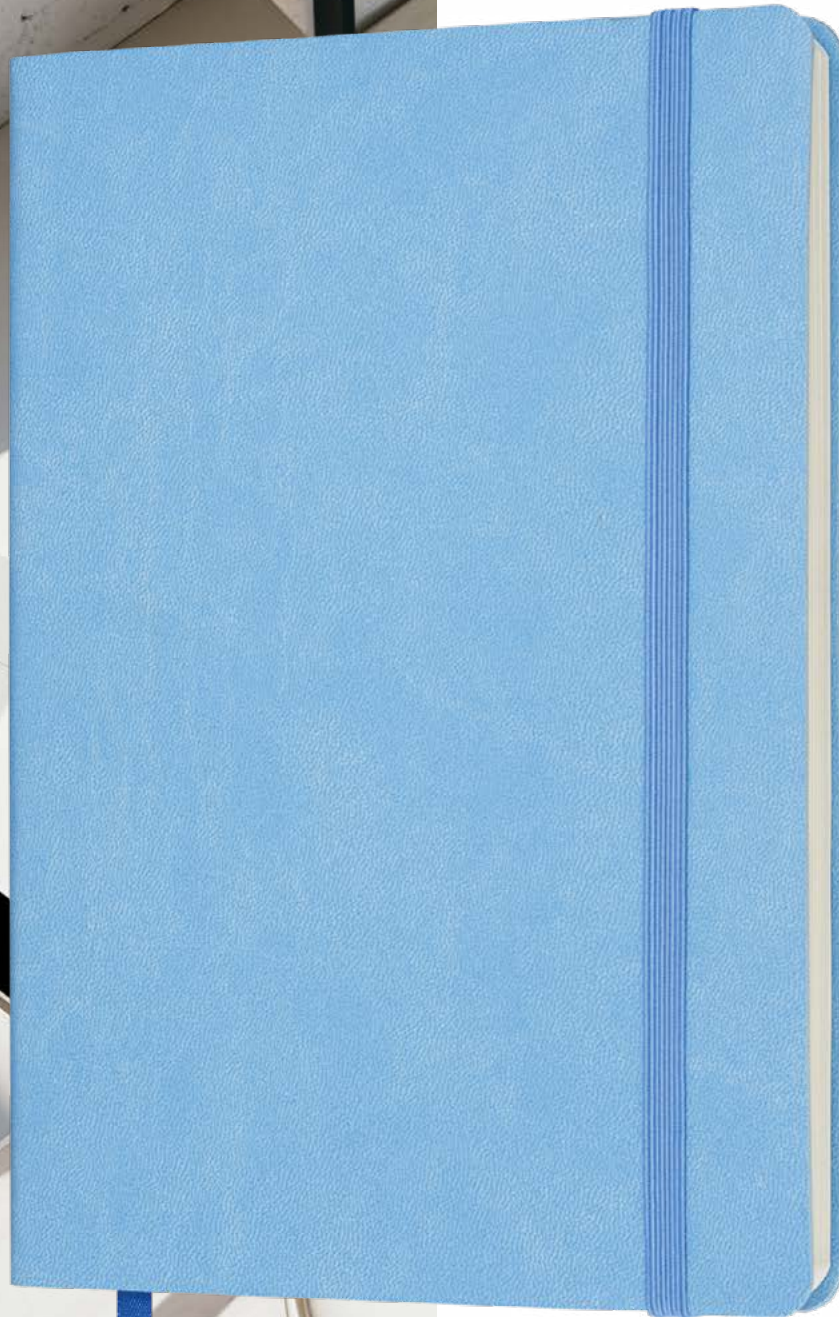

*While stocks last*



*table of contents*

Product code: EN24700/..

# MELLOW

## Colors

check it out!



**08**  
PMS 200



**22**  
PMS 2389



**24**  
PMS 3506



**30**  
PMS Cool Grey 7



**35**  
PMS Black

## Paper pattern



The mark of responsible forestry  
FSC® C118860

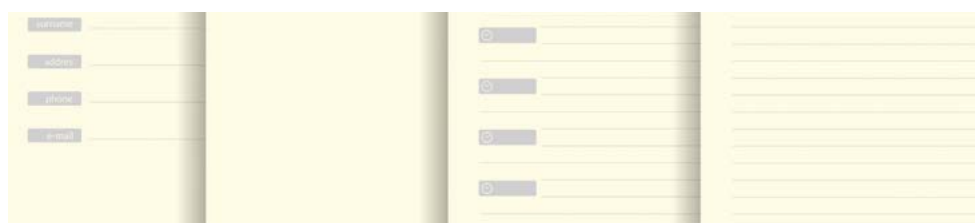

Planner lines

**EN**

Elastic notebook/planner with elastic band.

**PL**

Elastyczny notes/planer z gumką, miękka okładka.

**IT**

Taccuino/agenda con elastico.

**FR**

elastica Cahier/planificateur à élastique avec bande élastique.

**DE**

Flexibler mit weicher Einband.

**ES**

Notizbuch/Planificador elástico con banda elástica.

## Specification

|                       |              |                       |           |                       |                  |                   |   |                         |         |
|-----------------------|--------------|-----------------------|-----------|-----------------------|------------------|-------------------|---|-------------------------|---------|
| <b>Dimensions</b>     | 140 x 210 mm | <b>Pages / sheets</b> | 272 / 136 | <b>Cover material</b> | Soft Velvet (PU) | <b>Cover type</b> | Flexible  | <b>Packaging (pcs.)</b> | 20 / 40 |
| <b>Pages material</b> | Paper        | <b>Paper color</b>    | Chamois   | <b>Paper density</b>  | 70g              | <b>Extras</b>     | Elastic band, same color as cover - vertical, Ribbon, same color as cover |                         |         |

## Branding options

### Front cover

|  |              |
|--|--------------|
| Digital overprint                      | 110 x 180 mm |
| Silkscreen printing                    | 110 x 180 mm |
| Embossing                              | 110 x 180 mm |
| Foil stamping ( <i>metallic foil</i> ) | 110 x 180 mm |

### Back cover

|  |             |
|--|-------------|
| Digital overprint                      | 95 x 155 mm |
| Silkscreen printing                    | 95 x 155 mm |
| Embossing                              | 95 x 155 mm |
| Foil stamping ( <i>metallic foil</i> ) | 95 x 155 mm |





# VELVET



*While stocks last*



*table of contents*

Product code: EN24720/..

# VELVET

check it out!



## Colors

**05**  
PMS 715

**08**  
PMS 200

**22**  
PMS 2193

**24**  
PMS 2154

**30**  
PMS Cool Grey 7

**35**  
PMS Black

## Paper pattern



The mark of responsible forestry  
FSC® C118860

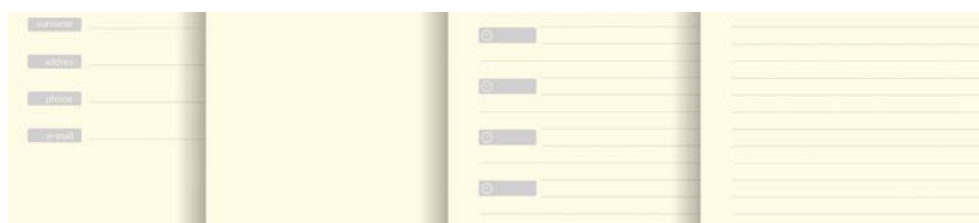

Planner lines

**EN**

Hard cover notebook/planner with double ribbon.

**PL**

Twardy notes/planer z dwoma wstążkami, twarda, softowana okładka.

**IT**

Taccuino/agenda con copertina rigida e doppio nastro.

**FR**

Cahier/planificateur à couverture rigide avec double ruban.

**DE**

Flexibles Notizbuch/Planner mit Gummiband, weicher Einband.

**ES**

Cuaderno/planificador de tapa dura con doble cinta.

## Specification

|                       |              |                       |           |                       |                      |                   |                                    |                         |         |
|-----------------------|--------------|-----------------------|-----------|-----------------------|----------------------|-------------------|------------------------------------|-------------------------|---------|
| <b>Dimensions</b>     | 140 x 210 mm | <b>Pages / sheets</b> | 272 / 136 | <b>Cover material</b> | Hard Silk Touch (PU) | <b>Cover type</b> | Hard                               | <b>Packaging (pcs.)</b> | 20 / 40 |
| <b>Pages material</b> | Paper        | <b>Paper color</b>    | Chamois   | <b>Paper density</b>  | 70g                  | <b>Extras</b>     | Double ribbon, same color as cover |                         |         |

## Branding options

### Front cover

|  |              |
|--|--------------|
| Digital overprint                      | 110 x 180 mm |
| Silkscreen printing                    | 110 x 180 mm |
| Embossing                              | 110 x 180 mm |
| Foil stamping ( <i>metallic foil</i> ) | 110 x 180 mm |

### Back cover

|  |              |
|--|--------------|
| Digital overprint                      | 110 x 155 mm |
| Silkscreen printing                    | 110 x 155 mm |
| Embossing                              | 110 x 155 mm |
| Foil stamping ( <i>metallic foil</i> ) | 110 x 155 mm |



Don't miss out on our end-of-series notebooks - explore them all before they're gone!





Premium promotional backpacks are made from durable, waterproof materials that provide protection against rain and splashes. High-quality materials with a fine weave, reinforced zippers, and metal pullers ensure both exceptional durability and an elegant look.



# SPARK

#BusinessonTheGo



Product code: BF970113/35

# SPARK

check it out!



Durable water-repellent main material

Ergonomic back and shoulder straps

Bright contrasting lining

Two side pockets

Silicone patch for headphone cables

USB port for charging the device

Reinforced laptop compartment  
inside 15,6"

Special RFID pocket



EN

**Fits 15.6" laptop**, USB port for charging, cardboard label with Bag & Fly logo, Inside the backpack is a non-woven storage bag. **Backpack designed for business use. Load limit: 7 kg** Backpack designed for business use. Backpack black color, 46x30x14 cm, 100% polyester.

PL

**Pasuje do laptopa 15,6"**, port USB do ładowania, etykieta kartonowa z logo Bag & Fly. Wewnątrz plecaka znajduje się torba do przechowywania z materiału nietkanego. **Plecak zaprojektowany do użytku biznesowego. Maksymalne obciążenie: 7 kg.** Plecak zaprojektowany do użytku biznesowego. Plecak czarny, 46x30x14 cm, 100% poliester.

IT

**Adatto per laptop da 15,6"**, porta USB per ricarica, etichetta di cartone con logo Bag & Fly. All'interno dello zaino c'è una borsa di stoccaggio in tessuto non tessuto. **Zaino progettato per uso aziendale. Limite di carico: 7 kg.** Zaino progettato per uso aziendale. Colore zaino nero, 46x30x14 cm, 100% poliestere.

FR

**Convient pour un ordinateur portable de 15,6"**, port USB pour la charge, étiquette en carton avec le logo Bag & Fly. À l'intérieur du sac à dos, il y a un sac de rangement en tissu non tissé. **Sac à dos conçu pour un usage professionnel. Limite de charge : 7 kg.** Sac à dos conçu pour un usage professionnel. Couleur du sac à dos noir, 46x30x14 cm, 100% polyester.

DE

**Passt für einen 15,6" Laptop**, USB-Port zum Laden, Kartonetikett mit Bag & Fly Logo. Im Rucksack befindet sich eine Aufbewahrungstasche aus Vliesstoff. **Rucksack für geschäftliche Zwecke entworfen. Belastungsgrenze: 7 kg.** Rucksack für den geschäftlichen Gebrauch. Farbe des Rucksacks: Schwarz, 46x30x14 cm, 100% Polyester.

ES

**Compatible con portátiles de 15,6"**, puerto USB para carga, etiqueta de cartón con el logo Bag & Fly. Dentro de la mochila hay una bolsa de almacenamiento de tela no tejida. **Mochila diseñada para uso empresarial. Límite de carga: 7 kg.** Mochila diseñada para uso empresarial. Color de la mochila: negro, 46x30x14 cm, 100% poliéster.

## Specification

|                   |                 |               |  |                 |                |                         |      |
|-------------------|-----------------|---------------|--|-----------------|----------------|-------------------------|------|
| <b>Dimensions</b> | 46 x 30 x 14 cm | <b>Extras</b> | Metal welts, USB port for charging, zippered pocket, organizer | <b>Material</b> | Polyester 100% | <b>Packaging (pcs.)</b> | 1/25 |
|-------------------|-----------------|---------------|--|-----------------|----------------|-------------------------|------|

## Branding options

Digital thermal transfer

Screen printing thermal transfer

Flex thermal transfer

A 100 x 30 mm

A 100 x 30 mm

A 100 x 30 mm

B 170 x 60 mm

B 170 x 60 mm

B 170 x 60 mm

Digital thermal transfer

Screen printing thermal transfer

Flex thermal transfer

C 100 x 20 mm

C 100 x 20 mm

C 100 x 20 mm

D 100 x 100 mm

D 100 x 100 mm

D 100 x 100 mm

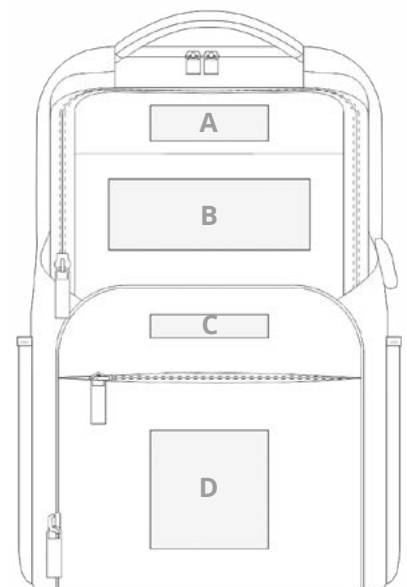

# BEAM

#TravelAndWork



Product code: BF970120/30

# BEAM

check it out!



Protective velcro strap

Ergonomic shoulder straps

USB port for charging devices

Reinforced laptop compartment  
inside 15,6"

Water-repellent main material

Comfortable organizer pocket

Silicone patch for headphone cables

Comfortable organizer pocket

Adjustable with plastic fasteners



EN

**Fits 15.6" laptop**, USB port for charging, cardboard label with Bag & Fly Logo. **Backpack designed for business use. Load limit: 7 kg.** Backpack designed for business use. Backpack grey / dark gray, 44x30x10 cm, 100% polyamide.

PL

**Pasuje do laptopa 15,6"**, port USB do ładowania, kartonowa etykieta z logo Bag & Fly. **Plecak zaprojektowany do użytku biznesowego. Maksymalne obciążenie: 7 kg** Plecak zaprojektowany do użytku biznesowego. Plecak szary / ciemnoszary, 44x30x10 cm, 100% poliamid.

IT

**Adatto per laptop da 15,6"**, porta USB per ricarica, etichetta di cartone con logo Bag & Fly. **Zaino progettato per uso aziendale. Limite di carico: 7 kg.** Zaino progettato per uso aziendale. Zaino grigio / grigio scuro, 44x30x10 cm, 100% poliamide.

FR

**Convient pour un ordinateur portable de 15,6"**, port USB pour la charge, étiquette en carton avec le logo Bag & Fly. **Sac à dos conçu pour un usage professionnel. Limite de charge : 7 kg.** Sac à dos conçu pour un usage professionnel. Sac à dos gris / gris foncé, 44x30x10 cm, 100% polyamide.

DE

**Passt für einen 15,6" Laptop**, USB-Port zum Laden, Kartonetikett mit Bag & Fly Logo. **Rucksack für geschäftliche Zwecke entworfen. Belastungsgrenze: 7 kg.** Rucksack für den geschäftlichen Gebrauch. Rucksack grau / dunkelgrau, 44x30x10 cm, 100% Polyamid.

ES

**Compatible con portátiles de 15,6"**, puerto USB para carga, etiqueta de cartón con el logo Bag & Fly. **Mochila diseñada para uso empresarial. Limite de carga: 7 kg.** Mochila diseñada para uso empresarial. Mochila gris / gris oscuro, 44x30x10 cm, 100% poliamida.

## Specification

|                   |                 |               |  |                 |                |                         |      |
|-------------------|-----------------|---------------|--|-----------------|----------------|-------------------------|------|
| <b>Dimensions</b> | 44 x 30 x 10 cm | <b>Extras</b> | Metal welts, USB port for charging, zippered pocket, organizer | <b>Material</b> | Polyester 100% | <b>Packaging (pcs.)</b> | 1/25 |
|-------------------|-----------------|---------------|--|-----------------|----------------|-------------------------|------|

## Branding options

|                                  |   |              |
|----------------------------------|---|--------------|
| Digital thermal transfer         | A | 150 x 150 mm |
| Screen printing thermal transfer | A | 150 x 150 mm |
| Flex thermal transfer            | A | 150 x 150 mm |
| Digital thermal transfer         | B | 150 x 150 mm |
| Screen printing thermal transfer | B | 150 x 150 mm |
| Flex thermal transfer            | B | 150 x 150 mm |

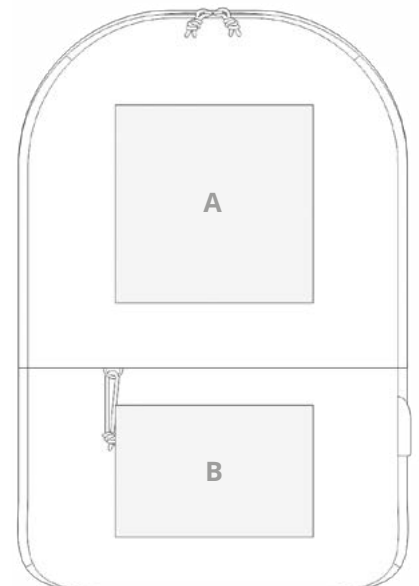

# GRAN

#CarryonBackpack



Product code: BF977989/30

# GRAN

check it out!



Durable water-repellent main material

Ergonomic back and shoulder straps

Comfortable pocket inside organizer

Silicone patch for headphone cables

A combination of textures materials

USB port for charging the device

Reinforced laptop compartment inside 15"

Zippered travel card pocket on shoulder strap and intelligent „anti-theft“ pocket



EN

**Fits a 15" laptop.** USB port for charging, cardboard label with Bag & Fly logo, inside the backpack is a non-woven. **Backpack designed for business use.** Load limit: 7 kg. Backpack designed for business use. Backpack grey / black, 47x28x11 cm, 100% polyester.

PL

**Pasuje do laptopa 15".** Port USB do ładowania, etykieta kartonowa z logo Bag & Fly, wewnątrz plecaka znajduje się materiał nietkany. **Plecak zaprojektowany do użytku biznesowego.** Maksymalne obciążenie: 7 kg. Plecak zaprojektowany do użytku biznesowego. Plecak szary / czarny, 47x28x11 cm, 100% poliester.

IT

**Adatto per laptop da 15",** porta USB per ricarica, etichetta di cartone con logo Bag & Fly. All'interno dello zaino c'è un materiale non tessuto. **Zaino progettato per uso aziendale.** Limite di carico: 7 kg. Zaino progettato per uso aziendale. Zaino grigio / nero, 47x28x11 cm, 100% poliestere.

FR

**Convient pour un ordinateur portable de 15",** port USB pour la charge, étiquette en carton avec le logo Bag & Fly. À l'intérieur du sac à dos, il y a un tissu non tissé. **Sac à dos conçu pour un usage professionnel.** Limite de charge : 7 kg. Sac à dos conçu pour un usage professionnel. Sac à dos gris / noir, 47x28x11 cm, 100% polyester.

DE

**Passt für einen 15" Laptop,** USB-Port zum Laden, Kartonetikett mit Bag & Fly Logo. Im Rucksack befindet sich ein Vliesstoff. **Rucksack für geschäftliche Zwecke entworfen.** Belastungsgrenze: 7 kg. Rucksack für den geschäftlichen Gebrauch. Rucksack grau / schwarz, 47x28x11 cm, 100% Polyester.

ES

**Compatible con portátiles de 15",** puerto USB para carga, etiqueta de cartón con el logo Bag & Fly. Dentro de la mochila hay un material no tejido. **Mochila diseñada para uso empresarial.** Límite de carga: 7 kg. Mochila diseñada para uso empresarial. Mochila gris / negra, 47x28x11 cm, 100% poliéster.

## Specification

|            |                 |        |  |          |                |                  |      |
|------------|-----------------|--------|--|----------|----------------|------------------|------|
| Dimensions | 47 x 28 x 11 cm | Extras | Metal welts, USB port for charging, zippered pocket, organizer | Material | Polyester 100% | Packaging (pcs.) | 1/20 |
|------------|-----------------|--------|--|----------|----------------|------------------|------|

## Branding options

|                                  |                |
|----------------------------------|----------------|
| Digital thermal transfer         | A 180 x 200 mm |
| Screen printing thermal transfer | A 180 x 200 mm |
| Flex thermal transfer            | A 180 x 200 mm |

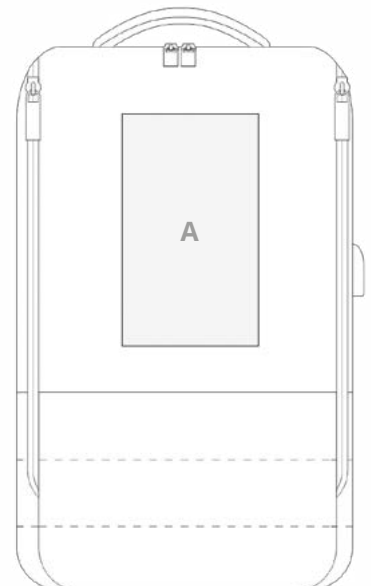

# LEIF

#WorkAnywhere



Product code: BF978071/30

# LEIF

check it out!



Water-repellent main material

Ergonomic back and shoulder straps

Comfortable pocket inside organizer

Pocket with a special rubberized lining for a wet umbrella

A combination of 2 textures materials

USB port for charging devices

Reinforced laptop compartment inside 15"

Zippered travel card pocket on shoulder strap



EN

**Fits a 15" laptop**, special rubberized pocket for folding umbrella, USB port for charging and cardboard label with Bag & Fly logo. Inside the backpack is a non-woven storage bag. **Backpack designed for business use. Load limit: 7 kg.** Backpack designed for business use. Backpack grey / black, 46x32x14 cm, 100% polyester.

PL

**Pasuje do laptopa 15"**. Specjalna gumowa kieszeń na składany parasol, port USB do ładowania oraz etykieta kartonowa z logo Bag & Fly. Wewnątrz plecaka znajduje się torba do przechowywania z materiału nietkanego. **Plecak zaprojektowany do użytku biznesowego. Maksymalne obciążenie: 7 kg** Plecak zaprojektowany do użytku biznesowego. Plecak szary / czarny, 46x32x14 cm, 100% poliester.

IT

**Adatto per laptop da 15"**, tasca in gomma speciale per ombrello pieghevole, porta USB per ricarica e etichetta di cartone con logo Bag & Fly. All'interno dello zaino c'è una borsa di stoccaggio in tessuto non tessuto. **Zaino progettato per uso aziendale. Limite di carico: 7 kg.** Zaino progettato per uso aziendale. Zaino grigio / nero, 46x32x14 cm, 100% poliester.

FR

**Convient pour un ordinateur portable de 15"**, poche en caoutchouc spécial pour parapluie pliant, port USB pour la charge et étiquette en carton avec le logo Bag & Fly. À l'intérieur du sac à dos, il y a un sac de rangement en tissu non tissé. **Sac à dos conçu pour un usage professionnel. Limite de charge : 7 kg.** Sac à dos conçu pour un usage professionnel. Sac à dos gris / noir, 46x32x14 cm, 100% polyester.

DE

**Passt für einen 15" Laptop**, spezielle gummierte Tasche für einen zusammenklappbaren Regenschirm, USB-Port zum Laden und Kartonetikett mit Bag & Fly Logo. Im Rucksack befindet sich eine Aufbewahrungstasche aus Vliesstoff. **Rucksack für geschäftliche Zwecke entworfen. Belastungsgrenze: 7 kg.** Rucksack für den geschäftlichen Gebrauch. Rucksack grau / schwarz, 46x32x14 cm, 100% Polyester.

ES

**Compatible con portátiles de 15"**, bolsillo de goma especial para paraguas plegable, puerto USB para carga y etiqueta de cartón con el logo Bag & Fly. Dentro de la mochila hay una bolsa de almacenamiento de tela no tejida. **Mochila diseñada para uso empresarial. Límite de carga: 7 kg.** Mochila diseñada para uso empresarial. Mochila gris / negra, 46x32x14 cm, 100% poliéster.

## Specification

|                   |                 |               |   |                 |                |                         |      |
|-------------------|-----------------|---------------|---|-----------------|----------------|-------------------------|------|
| <b>Dimensions</b> | 46 x 32 x 14 cm | <b>Extras</b> | USB port for charging, zippered pocket, organizer | <b>Material</b> | Polyester 100% | <b>Packaging (pcs.)</b> | 1/20 |
|-------------------|-----------------|---------------|---|-----------------|----------------|-------------------------|------|

## Branding options

|                                  |   |              |
|----------------------------------|---|--------------|
| Digital thermal transfer         | A | 100 x 50 mm  |
| Screen printing thermal transfer | A | 100 x 50 mm  |
| Flex thermal transfer            | A | 100 x 50 mm  |
| Digital thermal transfer         | B | 100 x 170 mm |
| Screen printing thermal transfer | B | 100 x 170 mm |
| Flex thermal transfer            | B | 100 x 170 mm |

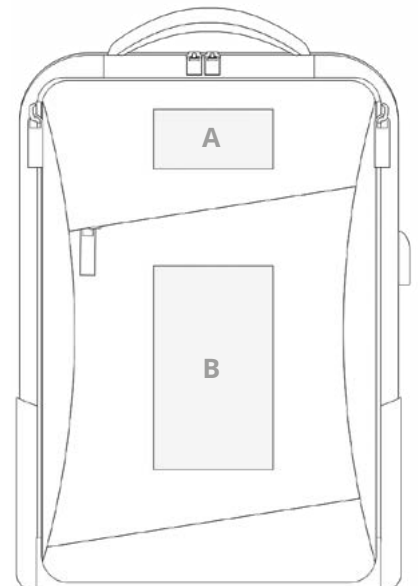





# LINK

#TravelWithStyle

Product code: BF971701/29

# LINK

check it out!



Water-repellent main material

Ergonomic back and shoulder straps

Bright contrasting lining+  
special RFID pocket

Two vertical zippered pockets

Outside zippered pocket

USB port for charging the device

Reinforced 15.6" laptop compartment

A rigid frame strength and additional  
protection

EN

**Fits a 15,6" laptop.** USB port for charging, cardboard label with Bag & Fly logo. **Backpack designed for business use.** Load limit: 7 kg. Backpack designed for business use. Backpack grey / black, 46x30x12 cm, 100% polyester

PL

**Pasuje do laptopa 15,6".** Port USB do ładowania, etykieta kartonowa z logo Bag & Fly. **Plecak zaprojektowany do użytku biznesowego.** Maksymalne obciążenie: 7 kg. Plecak zaprojektowany do użytku biznesowego. Plecak szary / czarny, 46x30x12 cm, 100% poliester.

IT

**Adatto per laptop da 15,6".** Porta USB per ricarica, etichetta di cartone con logo Bag & Fly. **Zaino progettato per uso aziendale.** Limite di carico: 7 kg. Zaino progettato per uso aziendale. Zaino grigio / nero, 46x30x12 cm, 100% poliestere.

FR

**Convient pour un ordinateur portable de 15,6".** Port USB pour la charge, étiquette en carton avec le logo Bag & Fly. **Sac à dos conçu pour un usage professionnel.** Limite de charge : 7 kg. Sac à dos conçu pour un usage professionnel. Sac à dos gris / noir, 46x30x12 cm, 100% polyester.

DE

**Passt für einen 15,6" Laptop.** USB-Port zum Laden, Kartonetikett mit Bag & Fly Logo. **Rucksack für geschäftliche Zwecke entworfen.** Belastungsgrenze: 7 kg. Rucksack für den geschäftlichen Gebrauch. Rucksack grau / schwarz, 46x30x12 cm, 100% Polyester.

ES

**Compatible con portátiles de 15,6".** Puerto USB para carga, etiqueta de cartón con el logo Bag & Fly. **Mochila diseñada para uso empresarial.** Limite de carga: 7 kg. Mochila diseñada para uso empresarial. Mochila gris / negra, 46x30x12 cm, 100% poliéster.

## Specification

|                   |                 |               |  |                 |                |                         |      |
|-------------------|-----------------|---------------|--|-----------------|----------------|-------------------------|------|
| <b>Dimensions</b> | 46 x 30 x 12 cm | <b>Extras</b> | Metal welts, USB port for charging, zippered pocket, organizer | <b>Material</b> | Polyester 100% | <b>Packaging (pcs.)</b> | 1/20 |
|-------------------|-----------------|---------------|--|-----------------|----------------|-------------------------|------|

## Branding options

|                                  |   |              |
|----------------------------------|---|--------------|
| Digital thermal transfer         | A | 100 x 80 mm  |
| Screen printing thermal transfer | A | 100 x 80 mm  |
| Flex thermal transfer            | A | 100 x 80 mm  |
| Digital thermal transfer         | B | 140 x 160 mm |
| Screen printing thermal transfer | B | 140 x 160 mm |
| Flex thermal transfer            | B | 140 x 160 mm |

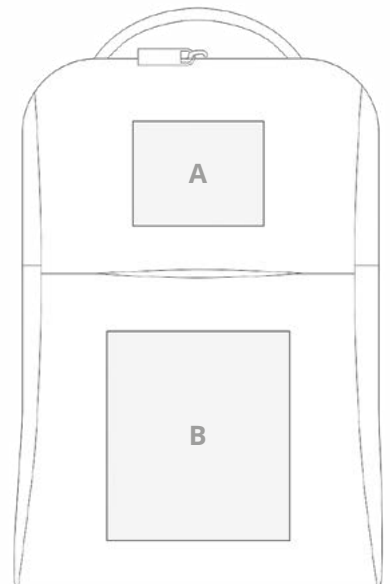

# Notebooks index



| Model               | 13 x 21 | 19 x 25 | 15 x 18 | 21 x 21 | 14 x 20 | 14 x 21 | Flexible | Semi-flexible | Hard | Lined | Squared | Dots | Blank | Elastic Band | Pen Holder |
|---------------------|---------|---------|---------|---------|---------|---------|----------|---------------|------|-------|---------|------|-------|--------------|------------|
| Lady GRS            | ●       |         |         |         |         |         | ●        |               |      | ●     |         |      |       |              |            |
| Shady GRS           |         |         |         |         | ●       |         | ●        |               |      | ●     | ●       | ●    |       | ●            |            |
| Gracy GRS / Gracy   | ●       |         |         |         |         |         | ●        |               |      | ●     |         |      |       | ●            | ●          |
| Funky GRS / Funky   | ●       |         |         |         |         |         | ●        |               |      | ●     |         |      |       |              |            |
| Biggy GRS           |         | ●       |         |         |         |         | ●        |               |      | ●     | ●       |      |       |              |            |
| Biggy               |         | ●       |         |         |         |         | ●        |               |      |       | ●       |      |       |              |            |
| Cubi GRS XL         |         |         |         | ●       |         |         | ●        |               |      |       | ●       |      |       |              |            |
| Cubi GRS / Cubi     |         |         | ●       |         |         |         | ●        |               |      | ●     |         |      |       |              |            |
| Audrey GRS / Audrey | ●       |         |         |         |         |         | ●        |               |      | ●     |         |      |       |              |            |
| Trendi GRS / Trendi | ●       |         |         |         |         |         |          |               | ●    | ●     |         |      |       |              |            |
| Twizzy GRS / Twizzy |         |         |         |         |         | ●       |          | ●             |      | ●     | ●       |      |       |              |            |
| Combi GRS / Combi   | ●       |         |         |         |         |         |          | ●             |      |       | ●       |      | ●     | ●            |            |
| Blacky GRS / Blacky |         |         |         |         |         | ●       |          | ●             |      |       | ●       |      |       | ●            |            |
| Franky GRS / Franky | ●       |         |         |         |         |         |          |               | ●    | ●     |         |      |       | ●            |            |
| Justy GRS           | ●       |         |         |         |         |         |          |               | ●    | ●     | ●       | ●    |       | ●            | ●          |
| Justy               | ●       |         |         |         |         |         |          |               | ●    | ●     |         |      |       | ●            | ●          |
| Silky GRS / Silky   | ●       |         |         |         |         |         |          |               | ●    |       | ●       |      |       | ●            | ●          |

| Model   | 13 x 21 | 19 x 25 | 15 x 18 | 21 x 21 | 14 x 20 | 14 x 21 | Flexible | Semi-flexible | Hard | Lined | Squared | Dots | Blank | Elastic Band | Pen Holder |
|---------|---------|---------|---------|---------|---------|---------|----------|---------------|------|-------|---------|------|-------|--------------|------------|
| Simply  | ●       |         |         |         |         |         |          | ●             |      |       | ●       |      |       |              |            |
| Mellow  |         |         |         |         |         | ●       | ●        |               |      | ●     |         |      |       | ●            |            |
| Flexi   | ●       |         |         |         |         |         | ●        |               |      | ●     |         |      |       |              |            |
| Imo     | ●       |         |         |         |         |         | ●        |               |      | ●     |         |      |       | ●            | ●          |
| Velvet  |         |         |         |         |         | ●       |          |               | ●    | ●     |         |      |       |              |            |
| Classic | ●       |         |         |         |         |         |          |               | ●    | ●     |         |      |       | ●            | ●          |
| Modern  | ●       |         |         |         |         |         |          |               | ●    |       | ●       |      |       | ●            | ●          |



[www.happybrands.promo](http://www.happybrands.promo)

Happy Brands Factory is a niche European manufacturer of **sustainable promotional pens and notebooks**, focusing on quality, sophisticated design and on-demand solutions.